

02

BFQ/D 大流量隔膜泵



BFQ-25 铝合金/不锈钢/铸钢



性能曲线图

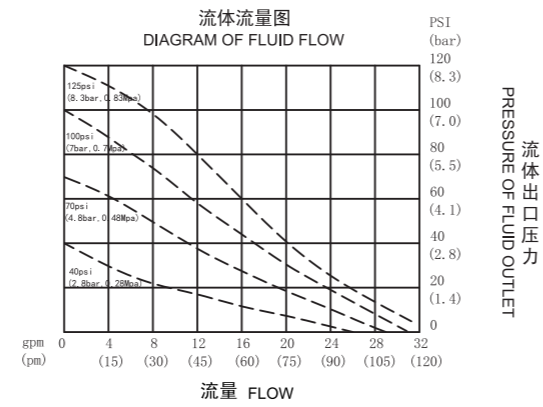

规格参数

最大工作流量 Max. Flow	31 gpm (116 lpm)	最大虹吸高度 (干抽或湿抽) Max.Suction Height (dry suction or wet suction)	18 ft. (5.48 m)
最大工作压力 Max. Working Pressure	120 psi (0.84 Mpa, 8.4 bar)	最大输送固体颗粒 Max. Permitted Grain	1/8 in. (3.2 mm)
流体进口尺寸 Fluid Inlet Size	1 in. bsp (f)	每往复流量 Every Reciprocating Flow	0.15 gal. (0.57 L)
流体出口尺寸 Fluid Outlet Size	1 in. bsp (f)	最大往复速度 Max. Reciprocating Speed	276 cpm
空气进口尺寸 Air Inlet Size	1/2 in. bsp (f)		

安装尺寸图

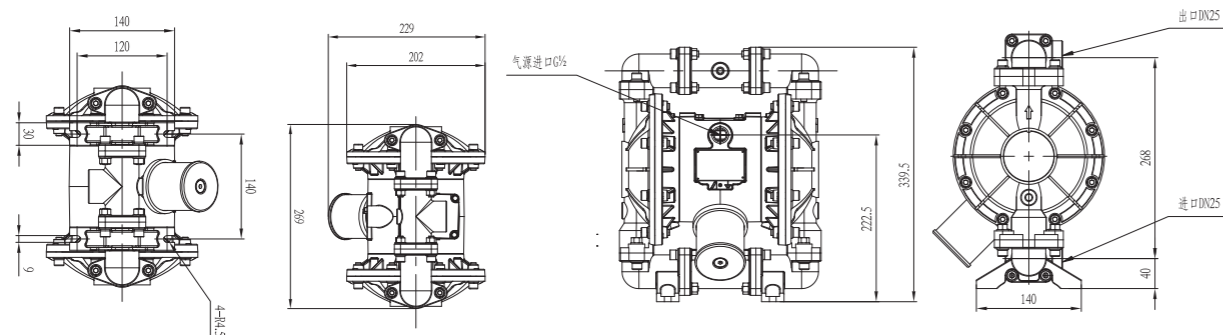
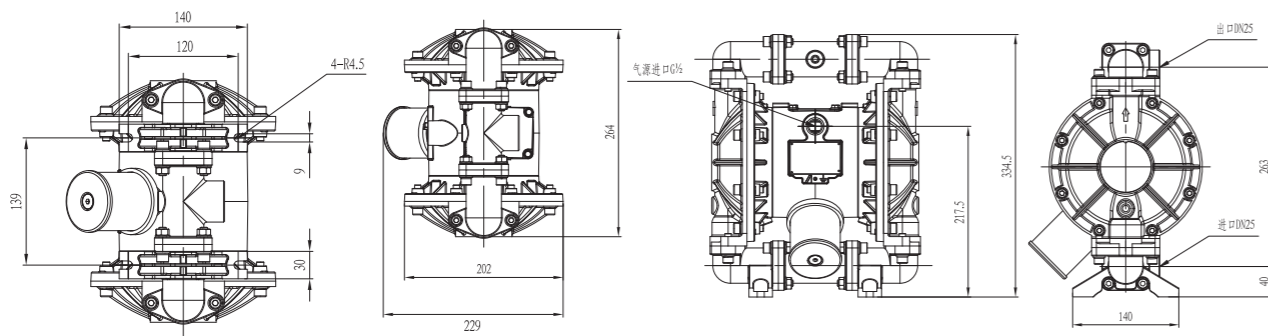

BFQ-25 塑料/氟塑料/衬氟



性能曲线图

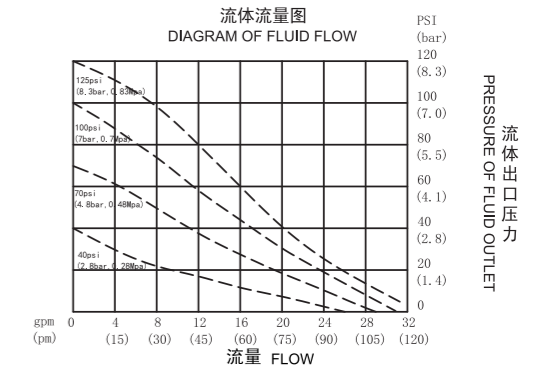

规格参数

最大工作流量 Max. Flow	31 gpm (116 lpm)	最大虹吸高度 (干抽或湿抽) Max.Suction Height (dry suction or wet suction)	18 ft. (5.48 m)
最大工作压力 Max. Working Pressure	120 psi (0.84 Mpa, 8.4 bar)	最大输送固体颗粒 Max. Permitted Grain	1/8 in. (3.2 mm)
流体进口尺寸 Fluid Inlet Size	1 in. bsp (f)	每往复流量 Every Reciprocating Flow	0.15 gal. (0.57 L)
流体出口尺寸 Fluid Outlet Size	1 in. bsp (f)	最大往复速度 Max. Reciprocating Speed	276 cpm
空气进口尺寸 Air Inlet Size	1/2 in. bsp (f)		

安装尺寸图

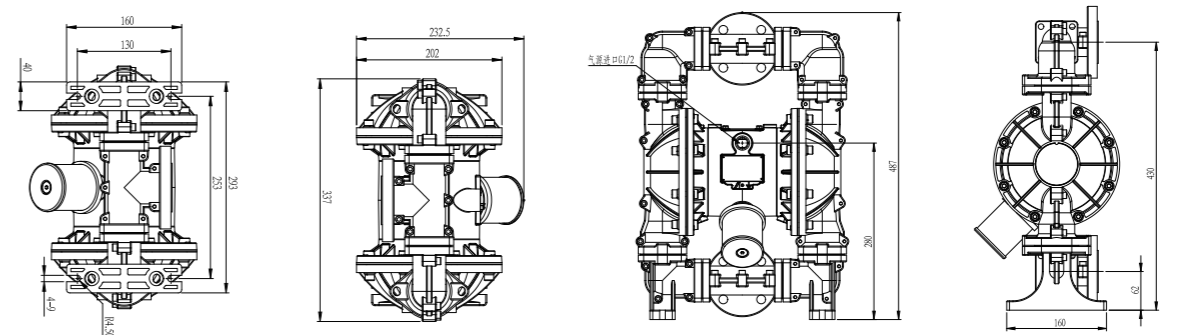
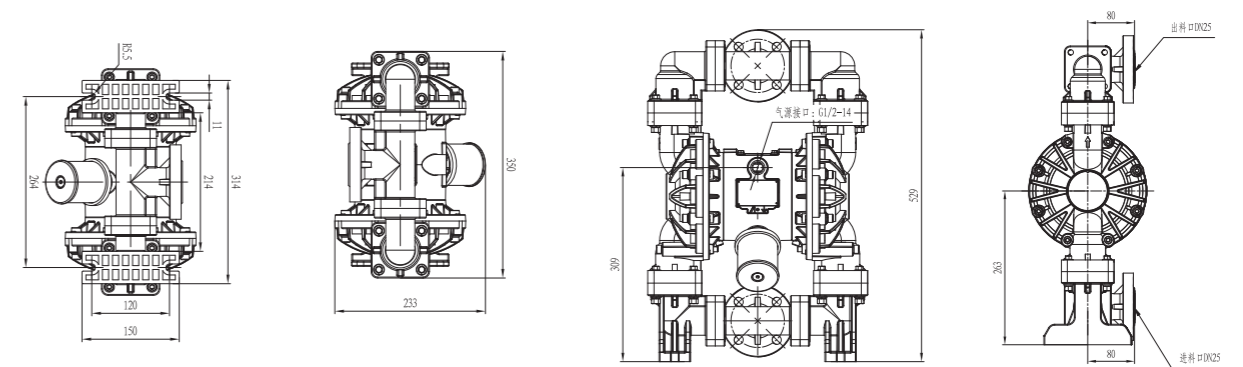

BFQ-40 铝合金/不锈钢/球铁



性能曲线图

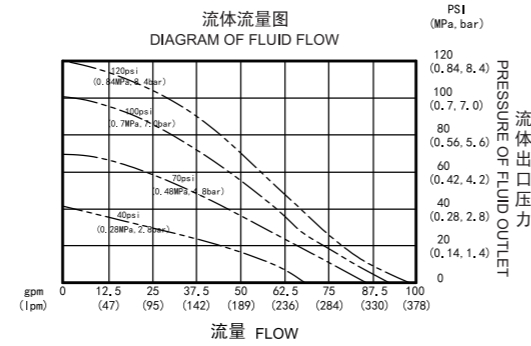

规格参数

最大工作流量 Max. Flow	100 gpm (378.5 lpm)	最大虹吸高度 (干抽或湿抽)	
最大工作压力 Max. Working Pressure	120 psi (0.84 Mpa, 8.4 bar)	Max.Suction Height (dry suction or wet suction)	18 ft. (5.48 m)
流体进口尺寸 Fluid Inlet Size	1-1/2 in. bsp (f)	最大输送固体颗粒 Max. Permitted Grain	3/16 in. (4.8 mm)
流体出口尺寸 Fluid Outlet Size	1-1/2 in. bsp (f)	每往复流量 Every Reciprocating Flow	0.5 gal. (1.9 L)
空气进口尺寸 Air Inlet Size	1/2 in. bsp (f)	最大往复速度 Max. Reciprocating Speed	200 cpm

安装尺寸图

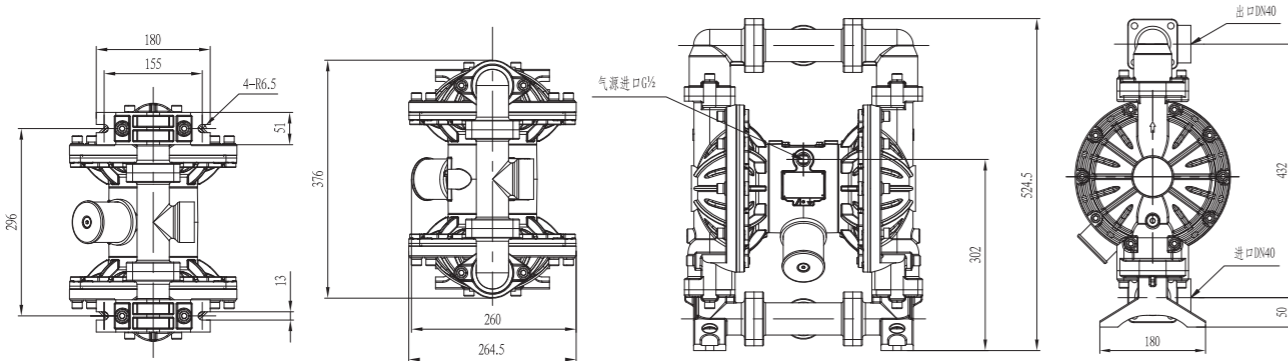

铝合金 Aluminum alloy

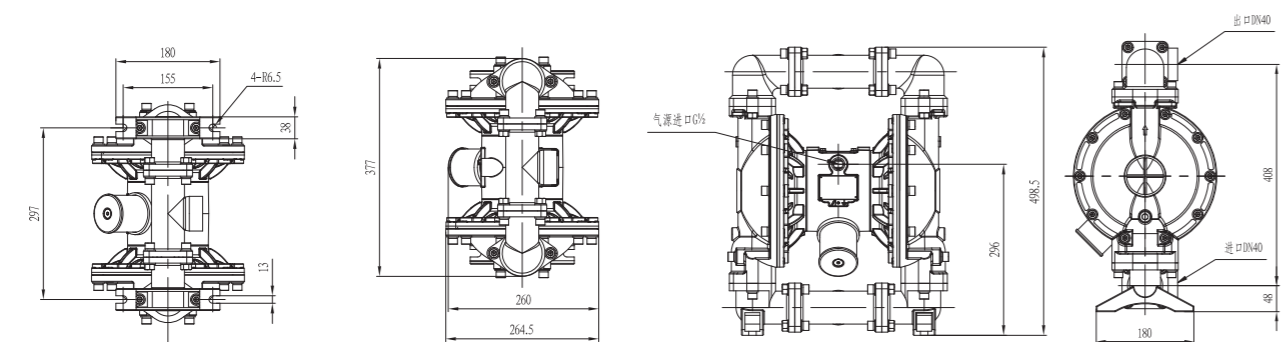

不锈钢/球铁 Stainless steel/Nodular cast iron

BFQ-40 塑料/氟塑料/衬氟



性能曲线图

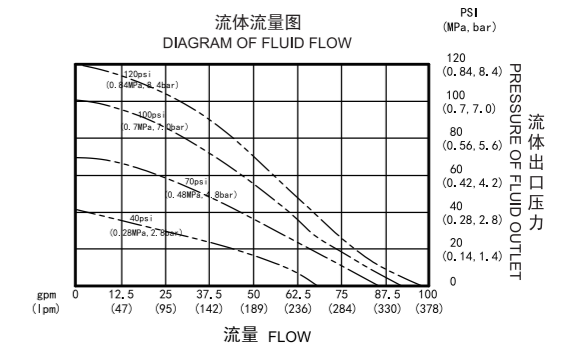

规格参数

最大工作流量 Max. Flow	100 gpm (378.5 lpm)	最大虹吸高度 (干抽或湿抽)	
最大工作压力 Max. Working Pressure	120 psi (0.84 Mpa, 8.4 bar)	Max.Suction Height (dry suction or wet suction)	18 ft. (5.48 m)
流体进口尺寸 Fluid Inlet Size	1-1/2 in. bsp (f)	最大输送固体颗粒 Max. Permitted Grain	3/16 in. (4.8 mm)
流体出口尺寸 Fluid Outlet Size	1-1/2 in. bsp (f)	每往复流量 Every Reciprocating Flow	0.5 gal. (1.9 L)
空气进口尺寸 Air Inlet Size	1/2 in. bsp (f)	最大往复速度 Max. Reciprocating Speed	200 cpm

安装尺寸图

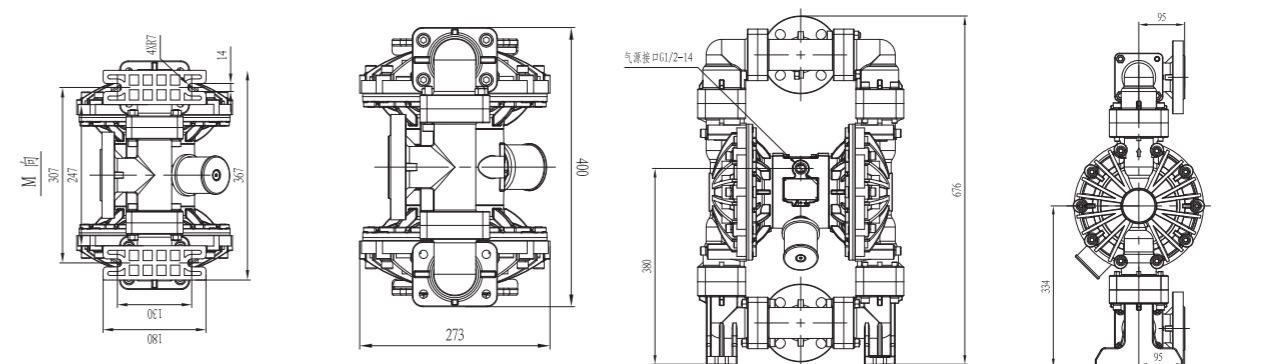

塑料/氟塑料 PP/PVDF

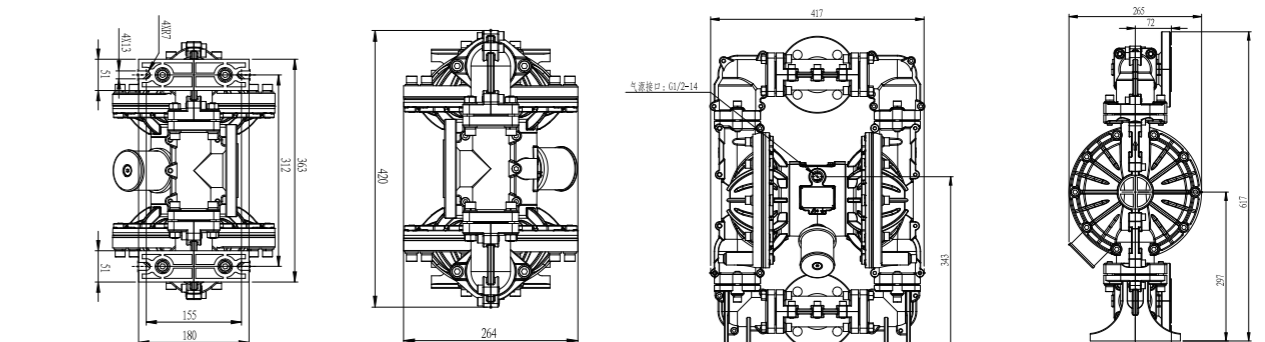

衬氟Lining PVDF

BFQ-50 铝合金/不锈钢/球铁



性能曲线图

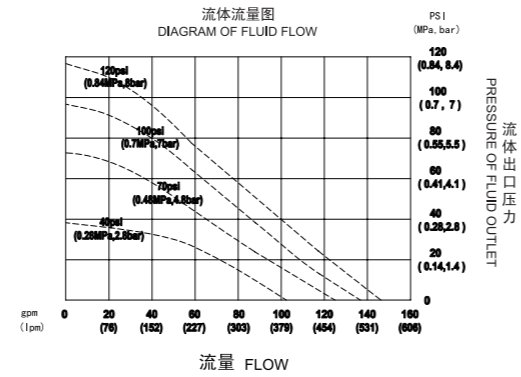

规格参数

最大工作流量 Max. Flow	150 gpm (568 lpm)	最大虹吸高度 (干抽或湿抽)	18 ft. (5.48 m)
最大工作压力 Max. Working Pressure	120 psi (0.84 Mpa, 8.4 bar)	Max.Suction Height (dry suction or wet suction)	18 ft. (5.48 m)
流体进口尺寸 Fluid Inlet Size	2 in. bsp (f)	最大输送固体颗粒 Max. Permitted Grain	1/4 in. (6.4 mm)
流体出口尺寸 Fluid Outlet Size	2 in. bsp (f)	每往复流量 Every Reciprocating Flow	1.03 gal. (3.90 L)
空气进口尺寸 Air Inlet Size	1/2 in. bsp (f)	最大往复速度 Max. Reciprocating Speed	145 cpm

安装尺寸图

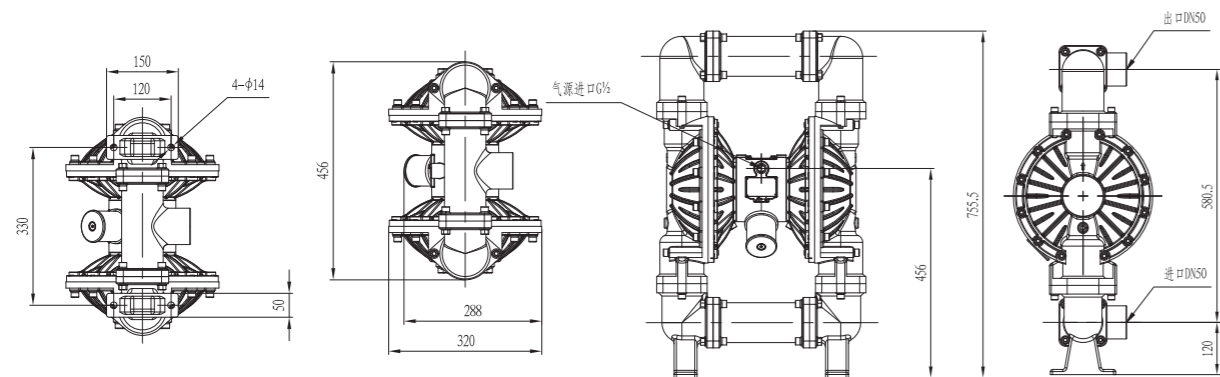

铝合金 Aluminum alloy

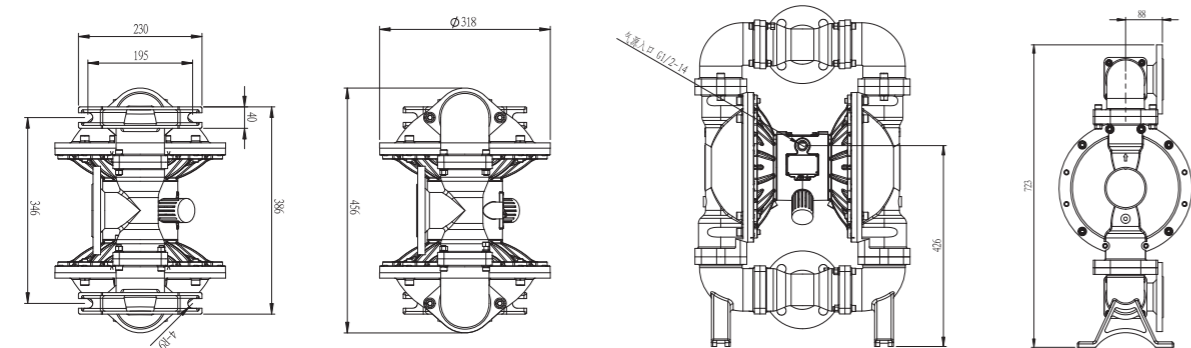

不锈钢/球铁 Stainless steel/Nodular cast iron

BFQ-50 塑料/氟塑料/衬氟

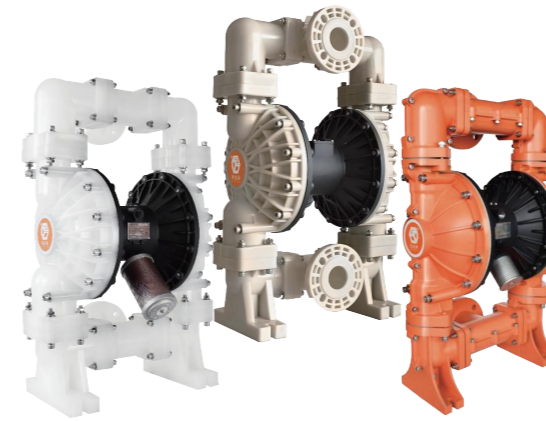

性能曲线图

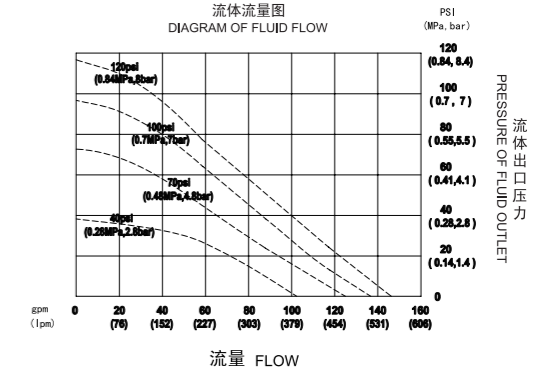

规格参数

最大工作流量 Max. Flow	150 gpm (568 lpm)	最大虹吸高度 (干抽或湿抽)	18 ft. (5.48 m)
最大工作压力 Max. Working Pressure	120 psi (0.84 Mpa, 8.4 bar)	Max.Suction Height (dry suction or wet suction)	18 ft. (5.48 m)
流体进口尺寸 Fluid Inlet Size	2 in. bsp (f)	最大输送固体颗粒 Max. Permitted Grain	1/4 in. (6.4 mm)
流体出口尺寸 Fluid Outlet Size	2 in. bsp (f)	每往复流量 Every Reciprocating Flow	1.03 gal. (3.90 L)
空气进口尺寸 Air Inlet Size	1/2 in. bsp (f)	最大往复速度 Max. Reciprocating Speed	145 cpm

安装尺寸图

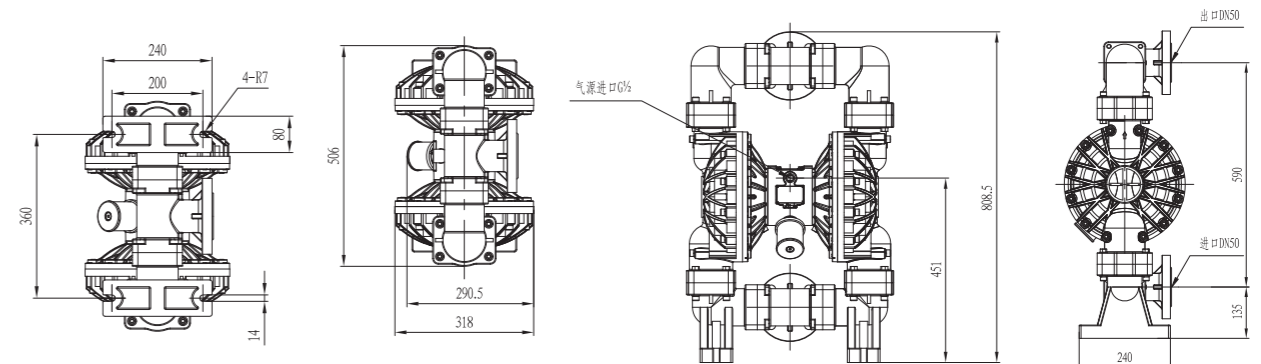

塑料/氟塑料 PP/PVDF

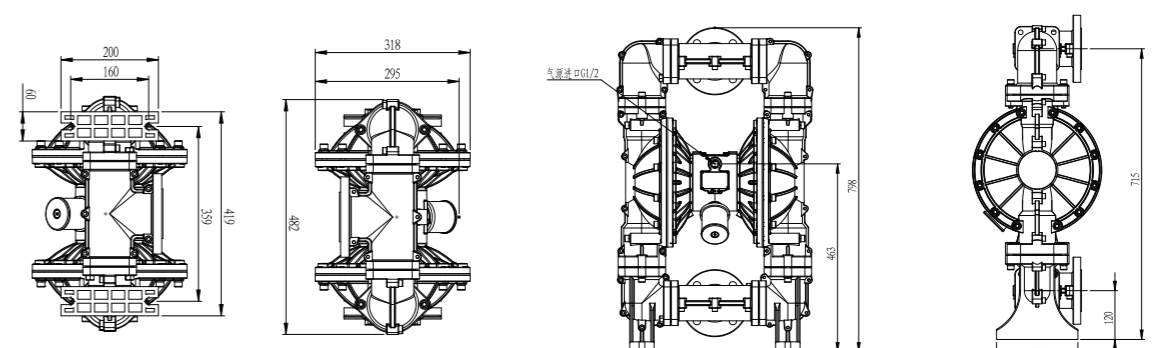

衬氟Lining PVDF

BFQ-125 不锈钢304



性能曲线图

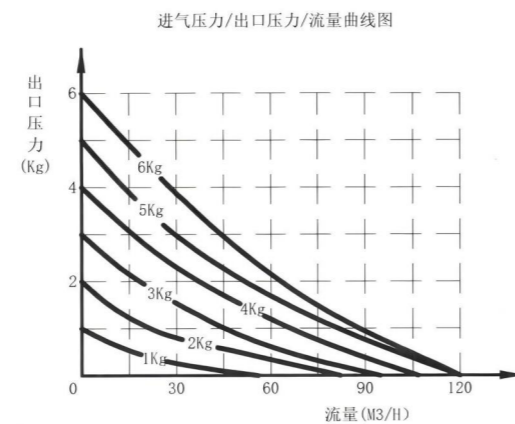

规格参数

最大工作流量 Max. Flow	528 gpm (2000 lpm)	最大虹吸高度 (干抽或湿抽)	
最大工作压力 Max. Working Pressure	90PSI	Max.Suction Height (dry suction or wet suction)	13 ft. (4 m)
流体进口尺寸 Fluid Inlet Size	DN125法兰	最大输送固体颗粒 Max. Permitted Grain	3/8 in. (9.4 mm)
流体出口尺寸 Fluid Outlet Size	DN125法兰	每往复流量 Every Reciprocating Flow	3.77gal/14L
空气进口尺寸 Air Inlet Size	G1-11	最大往复速度 Max. Reciprocating Speed	140 cpm

安装尺寸图

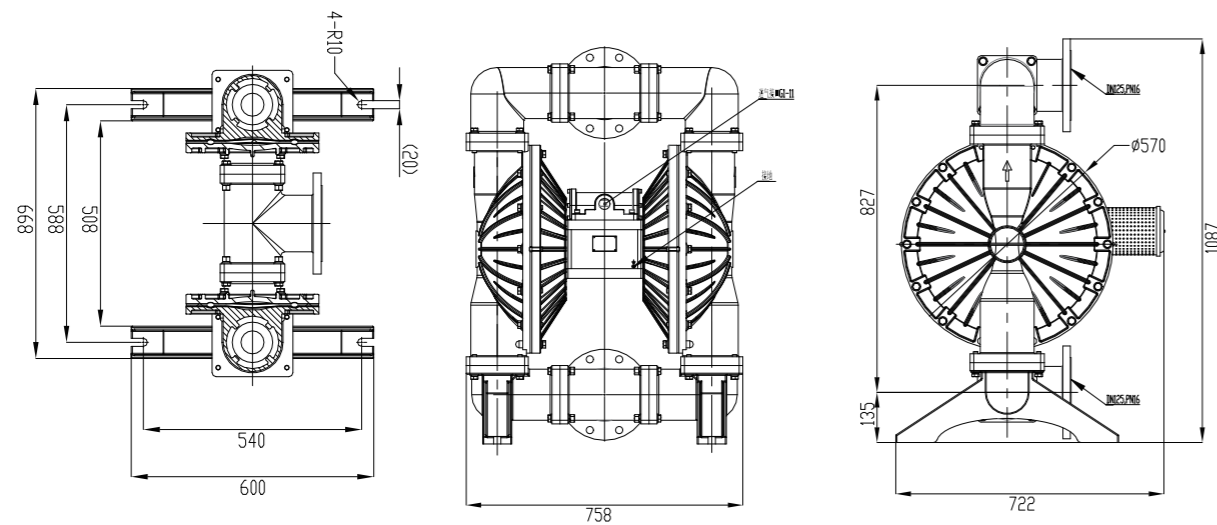

BFD-25 铝合金/不锈钢/铸钢

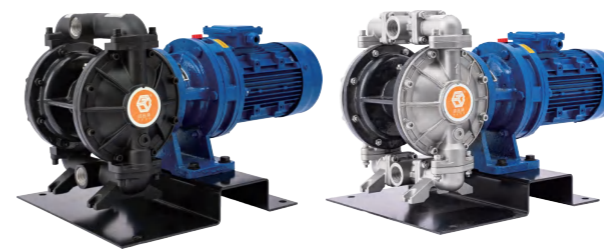

性能曲线图

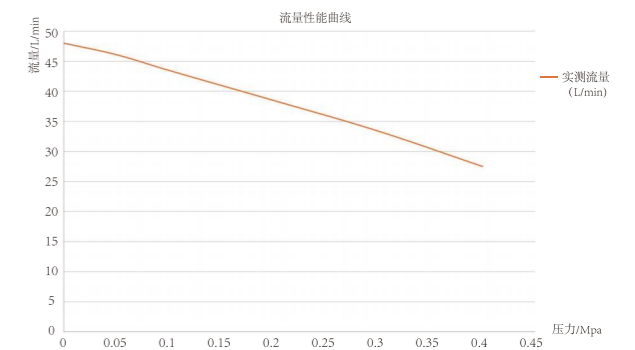

规格参数

最大工作流量 Max.Flow	12.7gpm (48lpm)	最大输送固体颗粒 Max.Permitted Grain	1/8in.(3.2mm)
最大工作压力 Max.Working Pressure	0.4Mpa / 0.7Mpa	每往复流量 Every Reciprocating Flow	0.15gallon(0.57L)
流体进口尺寸 Fluid Inlet Size	1in.bsp (f)	最大往复速度 Max.Reciprocating Speed	85cpm
流体出口尺寸 Fluid Outlet Size	1in.bsp (f)	出口压力 Outlet Pressure	0.4Mpa / 0.7Mpa
最大虹吸高度(干抽或湿抽)		电机功率 Motor power	1.5kw / 2.2kw
Max.Suction height(dry suction or wet suction)	13ft.(4m)		

安装尺寸图

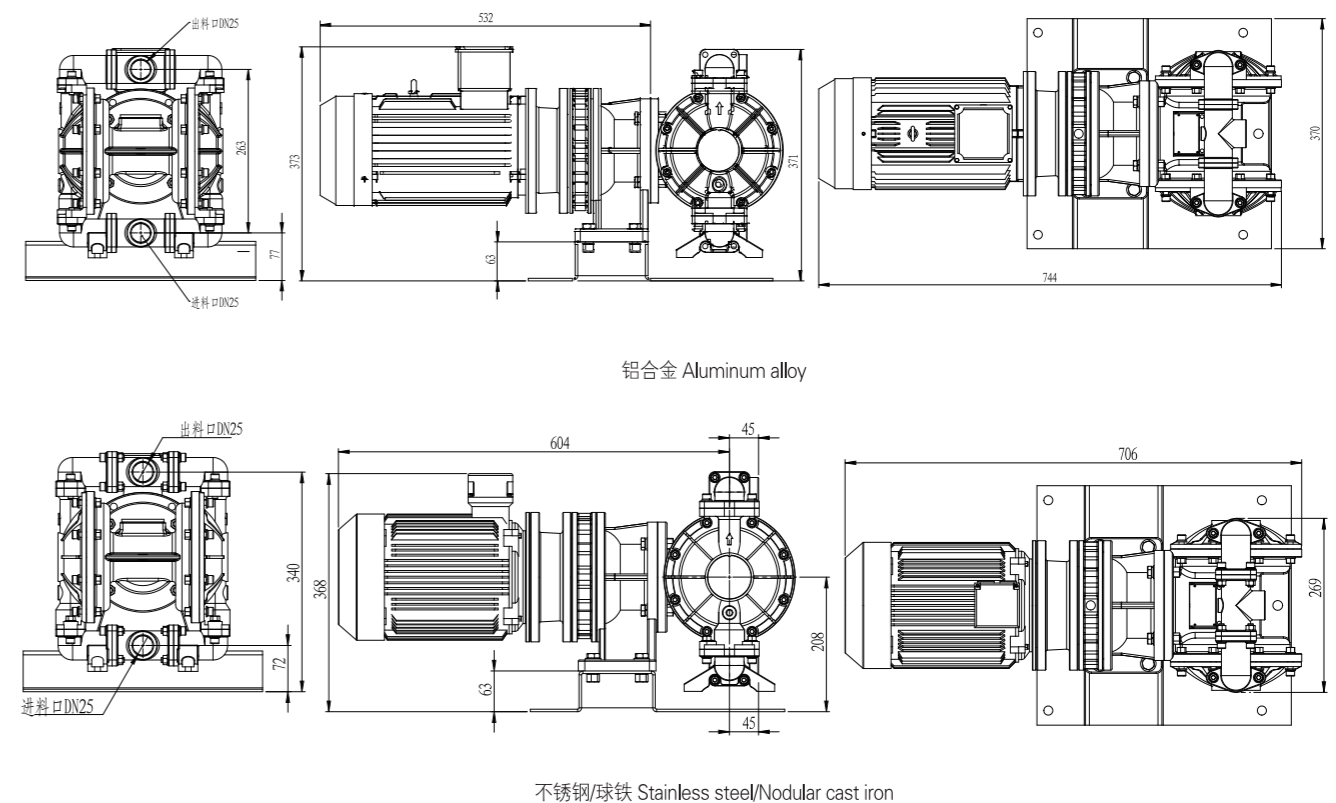

BFD-25 塑料/氟塑料/衬氟



性能曲线图

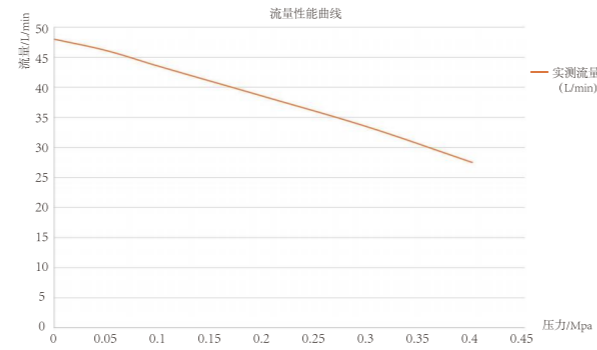

规格参数

最大工作流量 Max.Flow	12.7gpm (48Lpm)	最大输送固体颗粒 Max.Permitted Grain	1/8in.(3.2mm)
最大工作压力 Max.Working Pressure	0.4Mpa / 0.7Mpa	每往复流量 Every Reciprocating Flow	0.15gallon(0.57L)
流体进口尺寸 Fluid Inlet Size	1in.bsp (f)	最大往复速度 Max.Reciprocating Speed	85cpm
流体出口尺寸 Fluid Outlet Size	1in.bsp (f)	出口压力 Outlet Pressure	0.4Mpa / 0.7Mpa
最大虹吸高度(干抽或湿抽)		电机功率 Motor power	1.5kw / 2.2kw
Max.Suction height(dry suction or wet suction)	13ft.(4m)		

安装尺寸图

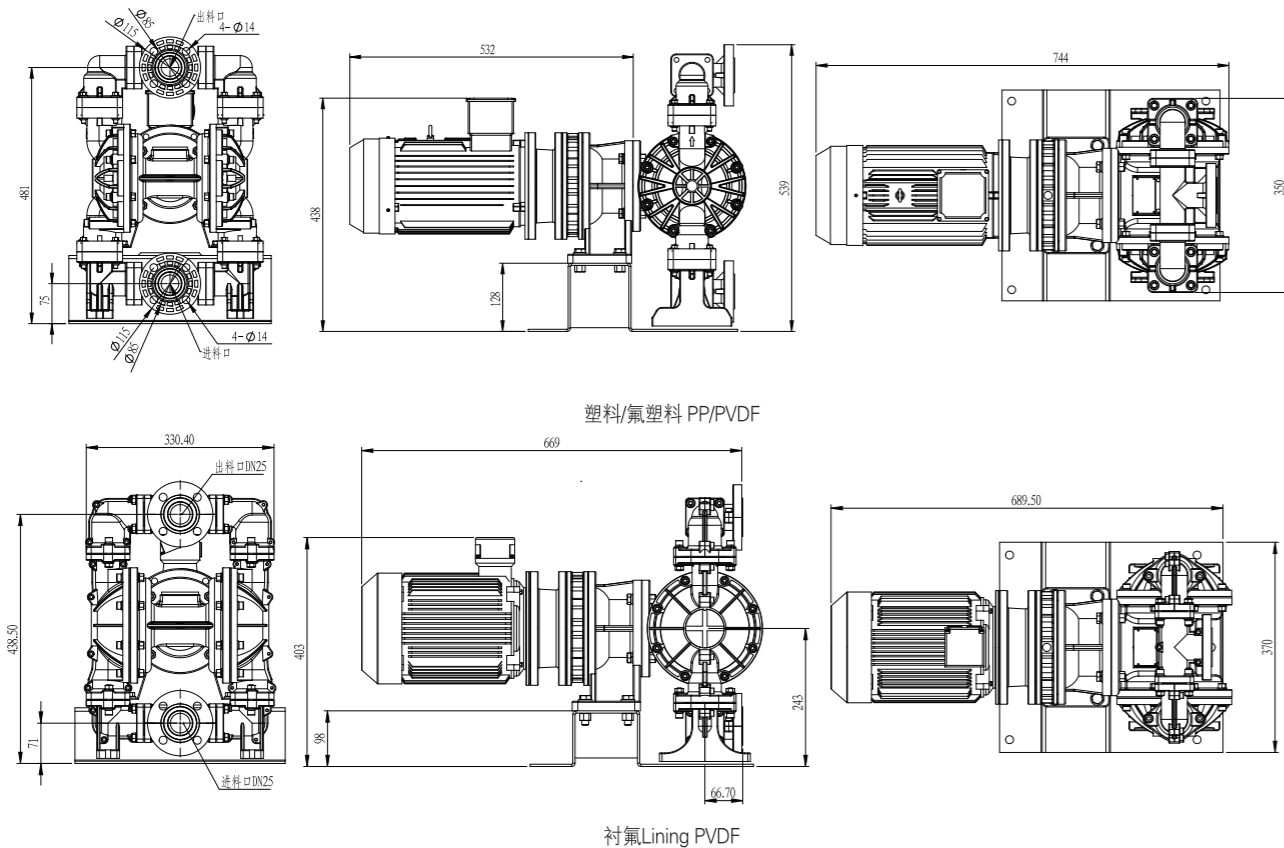

BFD-40 铝合金/不锈钢/球铁



性能曲线图

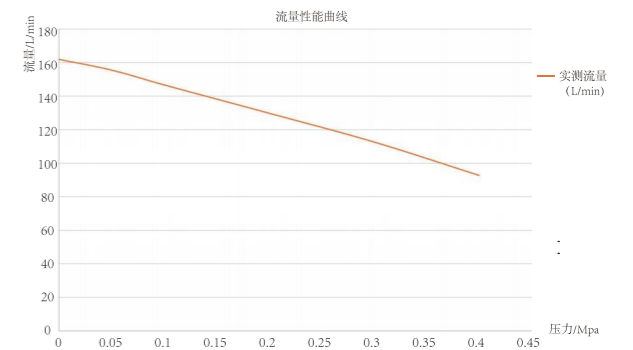

规格参数

最大工作流量 Max.Flow	42.8gpm (162lpm)	最大输送固体颗粒 Max.Permitted Grain	3/16in.(4.8mm)
最大工作压力 Max.Working Pressure	0.4Mpa / 0.7Mpa	每往复流量 Every Reciprocating Flow	0.5gallon(1.9L)
流体进口尺寸 Fluid Inlet Size	1-1/2in.bsp (f)	最大往复速度 Max.Reciprocating Speed	85cpm
流体出口尺寸 Fluid Outlet Size	1-1/2in.bsp (f)	出口压力 Outlet Pressure	0.4Mpa / 0.7Mpa
最大虹吸高度(干抽或湿抽)		电机功率 Motor power	2.2kw / 3kw
Max.Suction height(dry suction or wet suction)	16.4ft.(5m)		

安装尺寸图

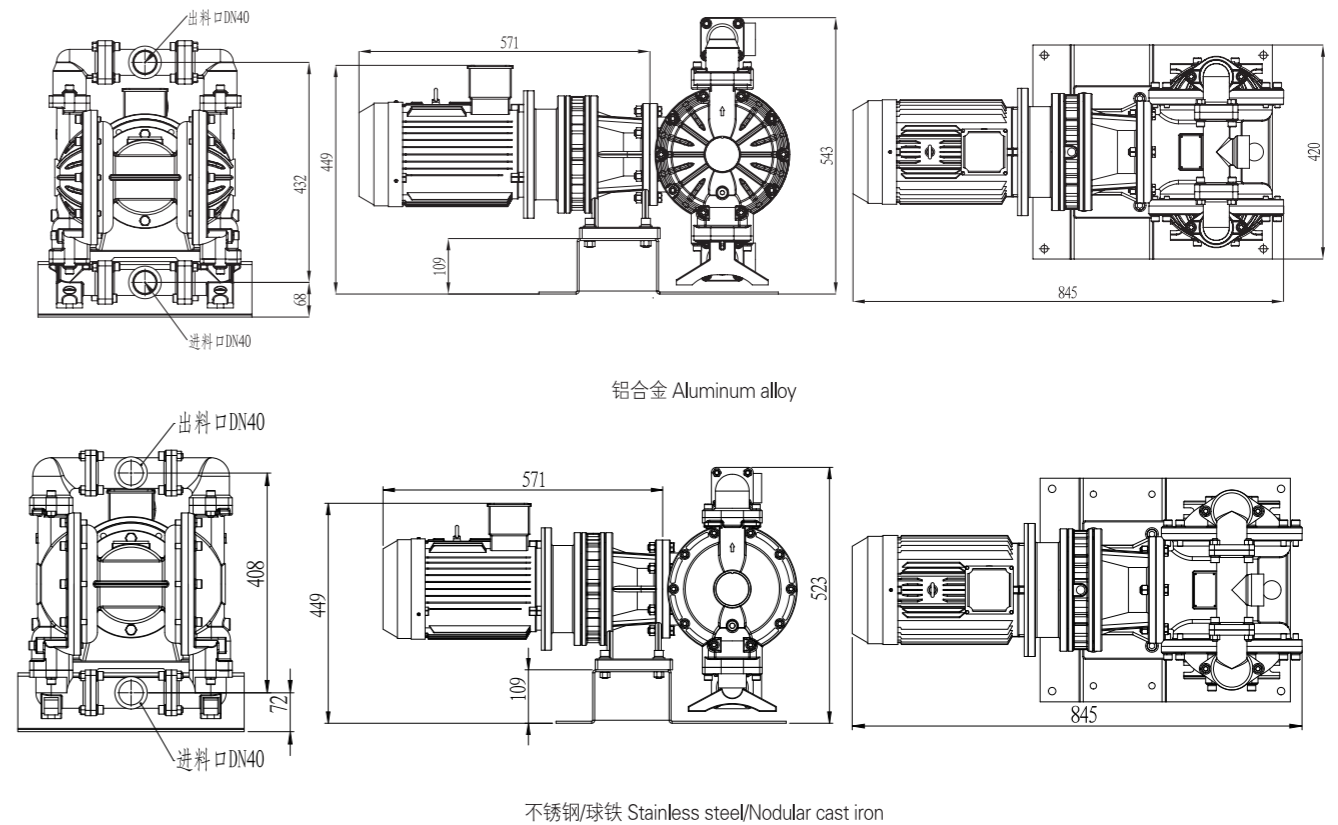

BFD-40 塑料/氟塑料/衬氟



性能曲线图

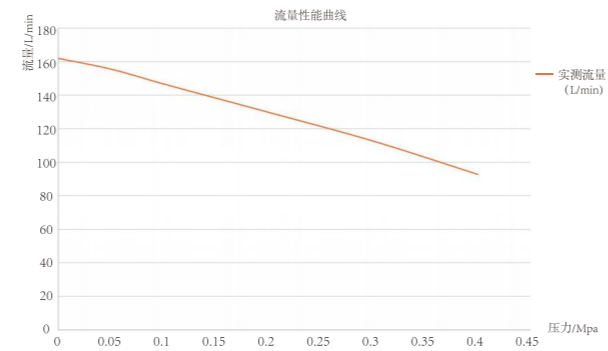

规格参数

最大工作流量 Max.Flow	42.8gpm (162lpm)	最大输送固体颗粒 Max.Permitted Grain	3/16in.(4.8mm)
最大工作压力 Max.Working Pressure	0.4Mpa / 0.7Mpa	每往复流量 Every Reciprocating Flow	0.5gallon(1.9L)
流体进口尺寸 Fluid Inlet Size	1-1/2in.bsp (f)	最大往复速度 Max.Reciprocating Speed	85cpm
流体出口尺寸 Fluid Outlet Size	1-1/2in.bsp (f)	出口压力 Outlet Pressure	0.4Mpa / 0.7Mpa
最大虹吸高度(干抽或湿抽) Max.Suction height(dry suction or wet suction)	16.4ft.(5m)	电机功率 Motor power	2.2kw / 3kw

安装尺寸图

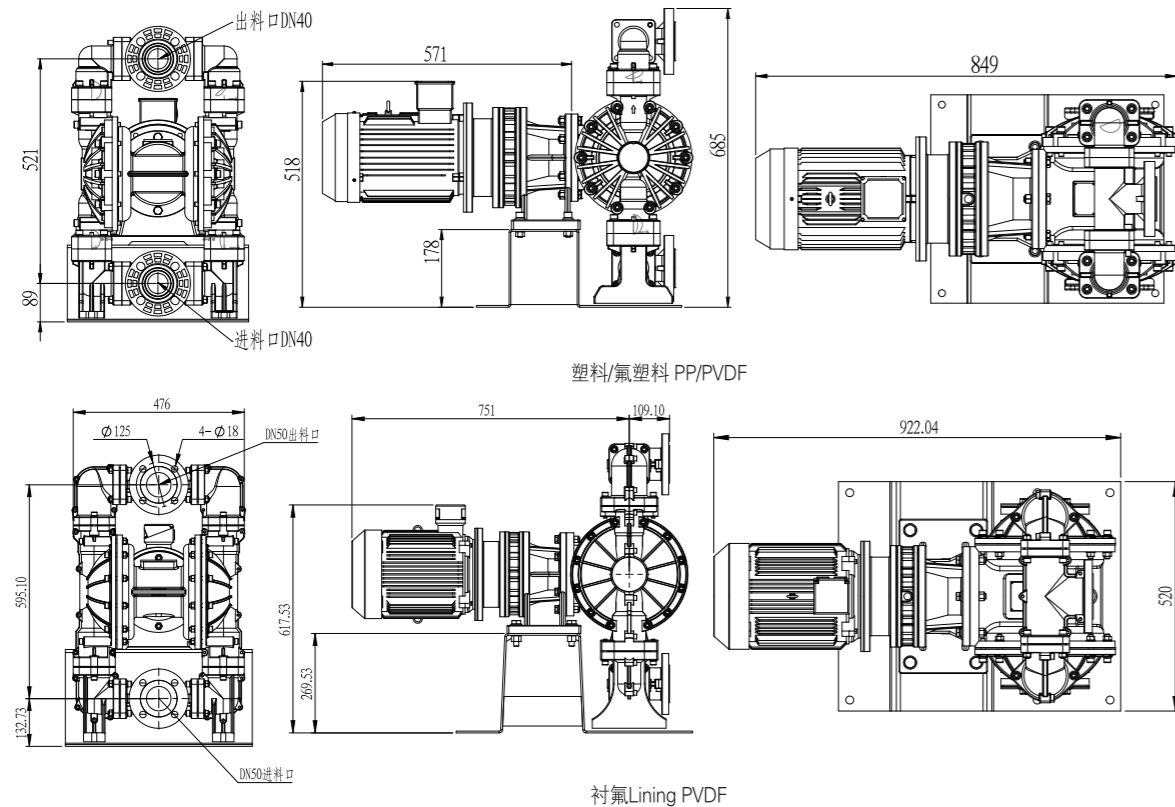

BFD-50 铝合金/不锈钢/球铁



性能曲线图



规格参数

最大工作流量 Max.Flow	64.7gpm (245lpm)	最大输送固体颗粒 Max.Permitted Grain	1/4in.(6.4mm)
最大工作压力 Max.Working Pressure	0.4Mpa / 0.7Mpa	每往复流量 Every Reciprocating Flow	1.03gallon(3.9L)
流体进口尺寸 Fluid Inlet Size	2in.bsp (f)	最大往复速度 Max.Reciprocating Speed	63cpm
流体出口尺寸 Fluid Outlet Size	2in.bsp (f)	出口压力 Outlet Pressure	0.4Mpa / 0.7Mpa
最大虹吸高度(干抽或湿抽) Max.Suction height(dry suction or wet suction)	16.4ft.(5m)	电机功率 Motor power	3kw / 4kw

安装尺寸图

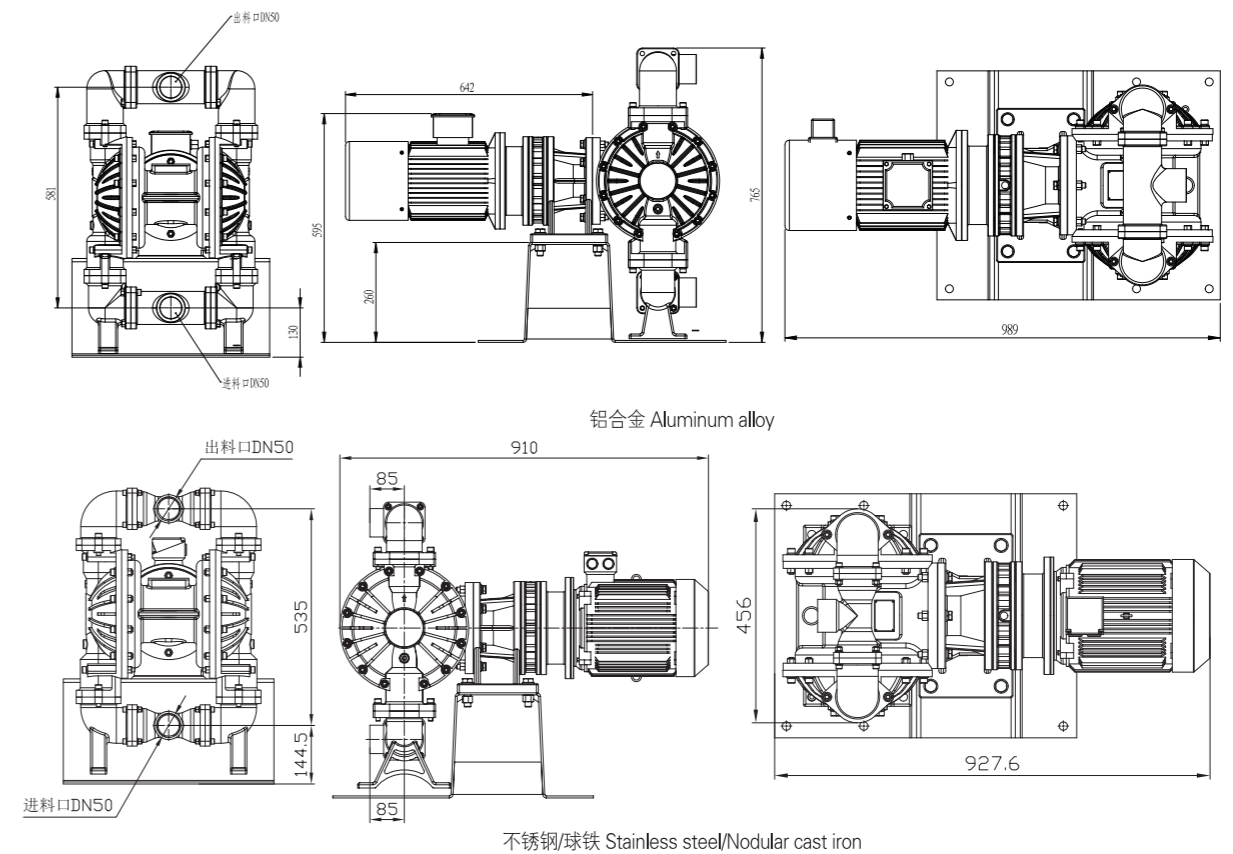

BFD-50 塑料/氟塑料/衬氟



性能曲线图

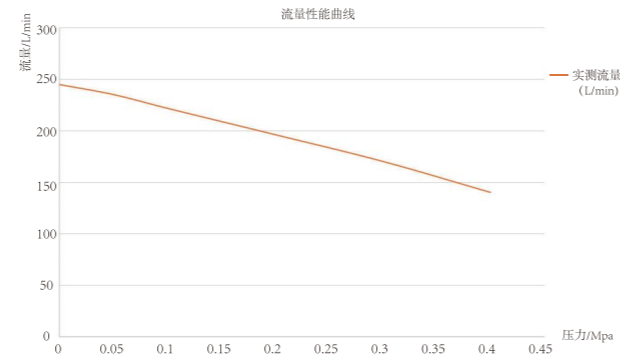

规格参数

最大工作流量 Max.Flow	64.7gpm (245lpm)	最大输送固体颗粒 Max.Permitted Grain	1/4in.(6.4mm)
最大工作压力 Max.Working Pressure	0.4Mpa / 0.7Mpa	每往复流量 Every Reciprocating Flow	1.03gallon(3.9L)
流体进口尺寸 Fluid Inlet Size	2in.bsp (f)	最大往复速度 Max.Reciprocating Speed	63cpm
流体出口尺寸 Fluid Outlet Size	2in.bsp (f)	出口压力 Outlet Pressure	0.4Mpa / 0.7Mpa
最大虹吸高度(干抽或湿抽) Max.Suction height(dry suction or wet suction)	16.4ft.(5m)	电机功率 Motor power	3kw / 4kw

安装尺寸图

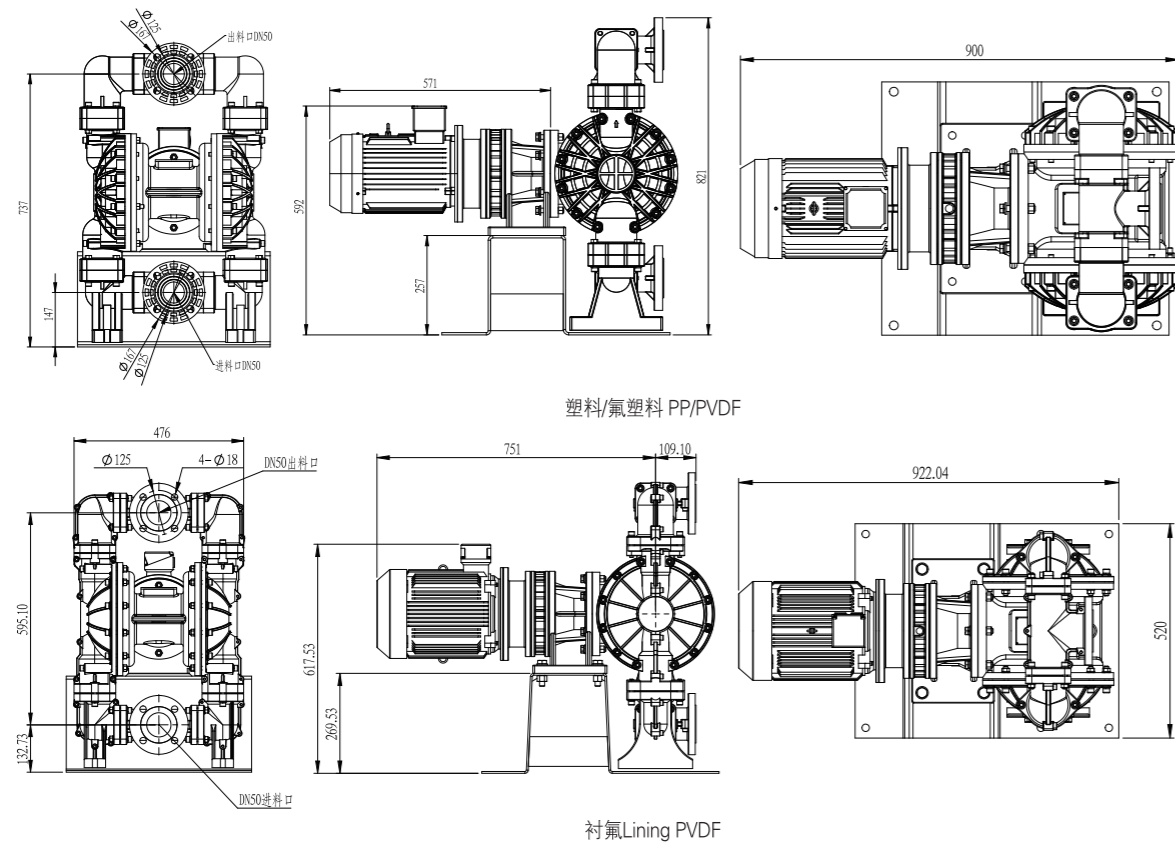

BFD-80 铝合金/不锈钢/球铁

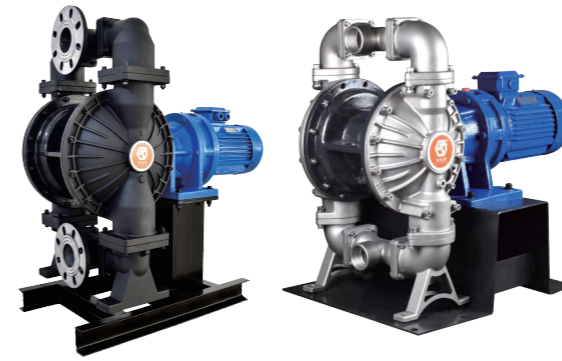

性能曲线图

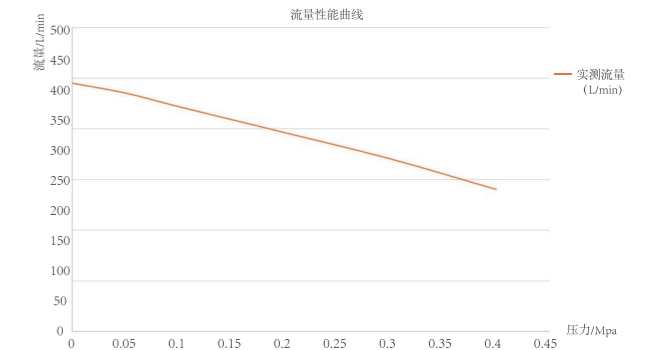

规格参数

最大工作流量 Max.Flow	126.8gpm (480Lpm)	最大输送固体颗粒 Max.Permitted Grain	3/8in.(9.4mm)
最大工作压力 Max.Working Pressure	0.4Mpa / 0.7Mpa	每往复流量 Every Reciprocating Flow	2.0gallon(7.6L)
流体进口尺寸 Fluid Inlet Size	3in.bsp (f)	最大往复速度 Max.Reciprocating Speed	63cpm
流体出口尺寸 Fluid Outlet Size	3in.bsp (f)	出口压力 Outlet Pressure	0.4Mpa / 0.7Mpa
最大虹吸高度(干抽或湿抽) Max.Suction height(dry suction or wet suction)	20ft.(6m)	电机功率 Motor power	4kw / 5.5kw

安装尺寸图

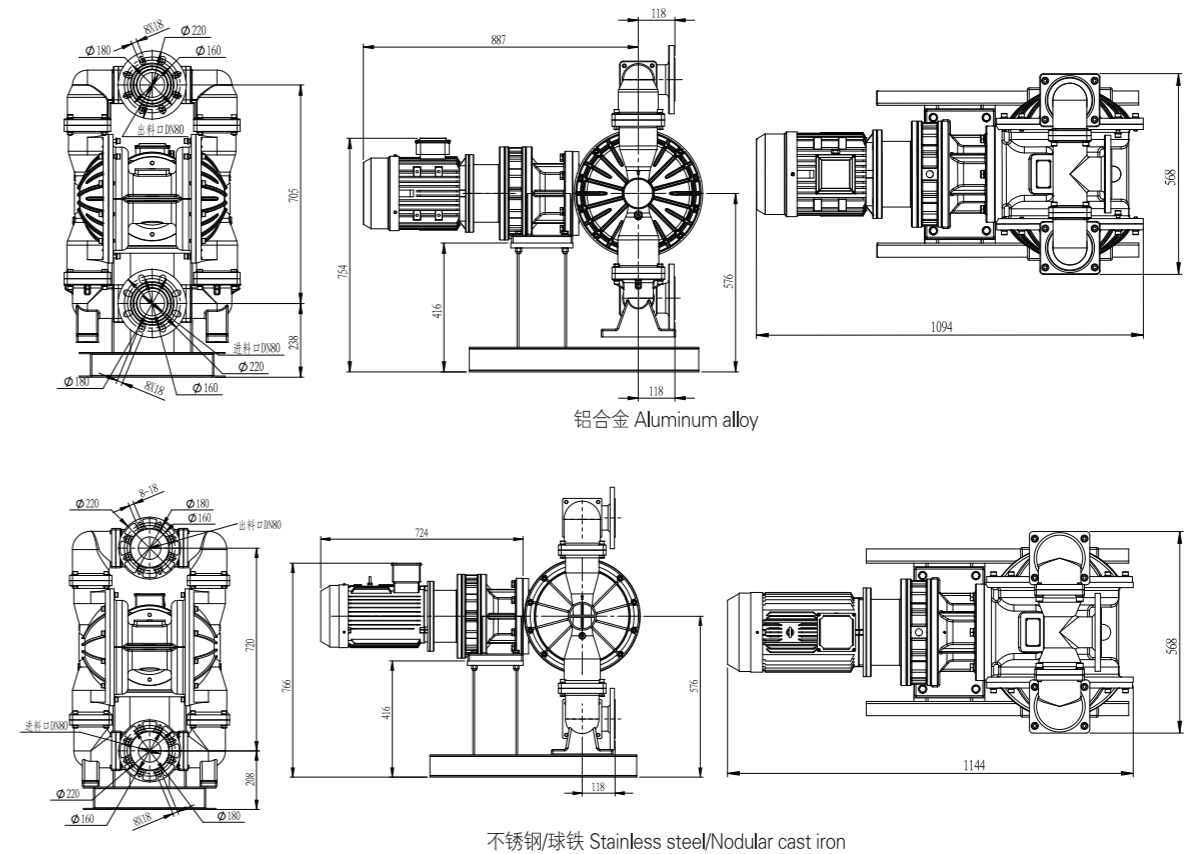

BFD-80 塑料/氟塑料/衬氟



性能曲线图

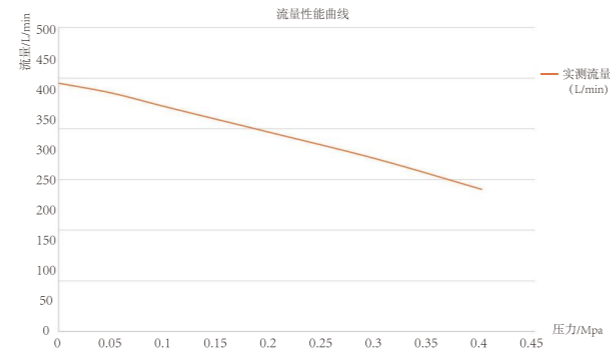

规格参数

最大工作流量 Max.Flow	126.8gpm (480Lpm)	最大输送固体颗粒 Max.Permitted Grain	3/8in.(9.4mm)
最大工作压力 Max.Working Pressure	0.4Mpa / 0.7Mpa	每往复流量 Every Reciprocating Flow	2.0gallon(7.6L)
流体进口尺寸 Fluid Inlet Size	3in. bsp (f)	最大往复速度 Max.Reciprocating Speed	63cpm
流体出口尺寸 Fluid Outlet Size	3in. bsp (f)	出口压力 Outlet Pressure	0.4Mpa / 0.7Mpa
最大虹吸高度(干抽或湿抽)		电机功率 Motor power	4kw / 5.5kw
Max.Suction height(dry suction or wet suction)	20ft.(6m)		

安装尺寸图

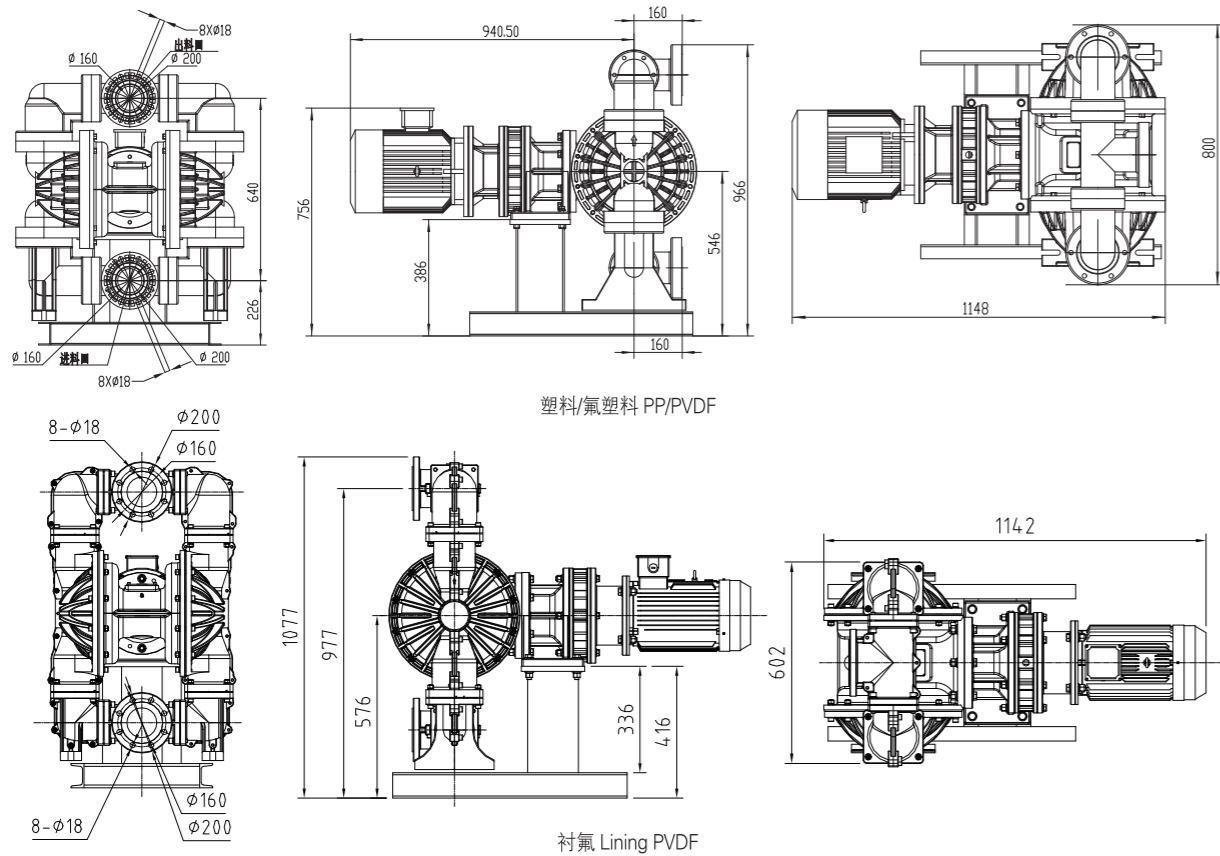

BFQJ-40 不锈钢/不锈钢316



性能曲线图

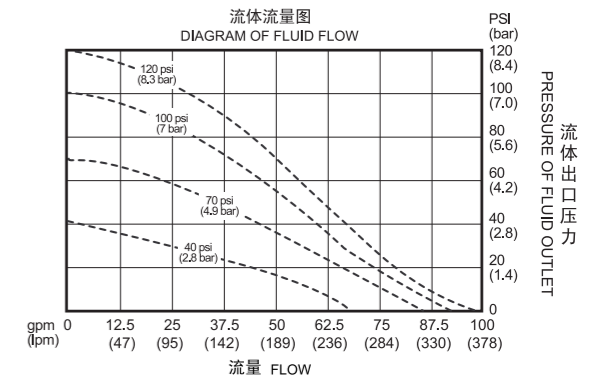

规格参数

最大工作流量 Max. Flow	100 gpm (378.5 lpm)	最大虹吸高度 (干抽或湿抽)	18 ft. (5.48 m)
最大工作压力 Max. Working Pressure	120 psi (0.84 Mpa, 8.4 bar)	Max.Suction Height (dry suction or wet suction)	3/16 in. (4.8 mm)
流体进口尺寸 Fluid Inlet Size	1-1/2 in. bsp (f)	最大输送固体颗粒 Max. Permitted Grain	0.5 gal. (1.9 L)
流体出口尺寸 Fluid Outlet Size	1-1/2 in. bsp (f)	每往复流量 Every Reciprocating Flow	200 cpm
空气进口尺寸 Air Inlet Size	1/2 in. bsp (f)	最大往复速度 Max. Reciprocating Speed	

安装尺寸图

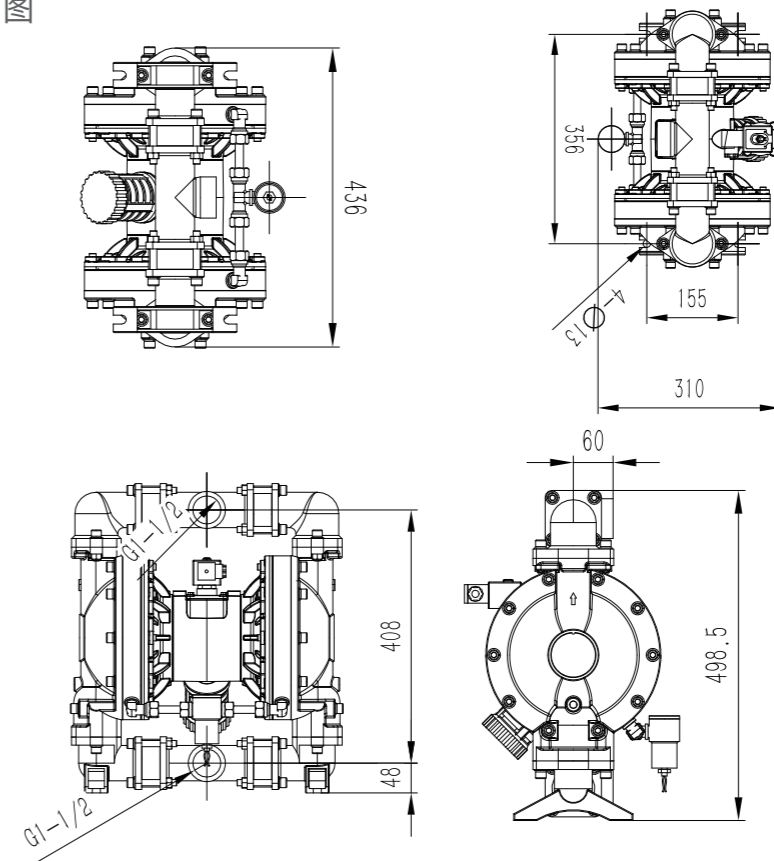

BFQJ-50 不锈钢/不锈钢316



性能曲线图

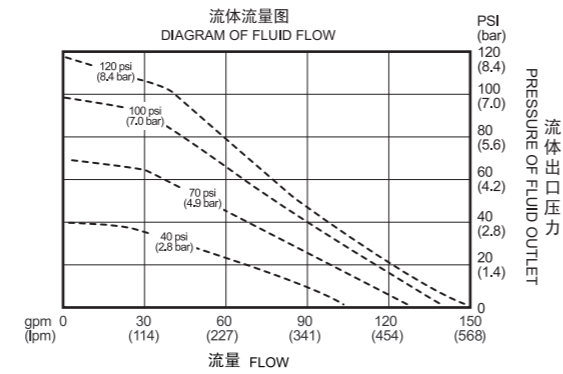

规格参数

最大工作流量 Max. Flow	150 gpm (568 lpm)	最大虹吸高度 (干抽或湿抽) Max.Suction Height (dry suction or wet suction)	18 ft. (5.48 m)
最大工作压力 Max. Working Pressure	120 psi (0.84 Mpa, 8.4 bar)	最大输送固体颗粒 Max. Permitted Grain	45 scfm
流体进口尺寸 Fluid Inlet Size	2 in. bsp (f)	每往复流量 Every Reciprocating Flow	1.03 gal. (3.90 L)
流体出口尺寸 Fluid Outlet Size	2 in. bsp (f)	最大往复速度 Max. Reciprocating Speed	145 cpm
空气进口尺寸 Air Inlet Size	1/2 in. bsp (f)		

安装尺寸图

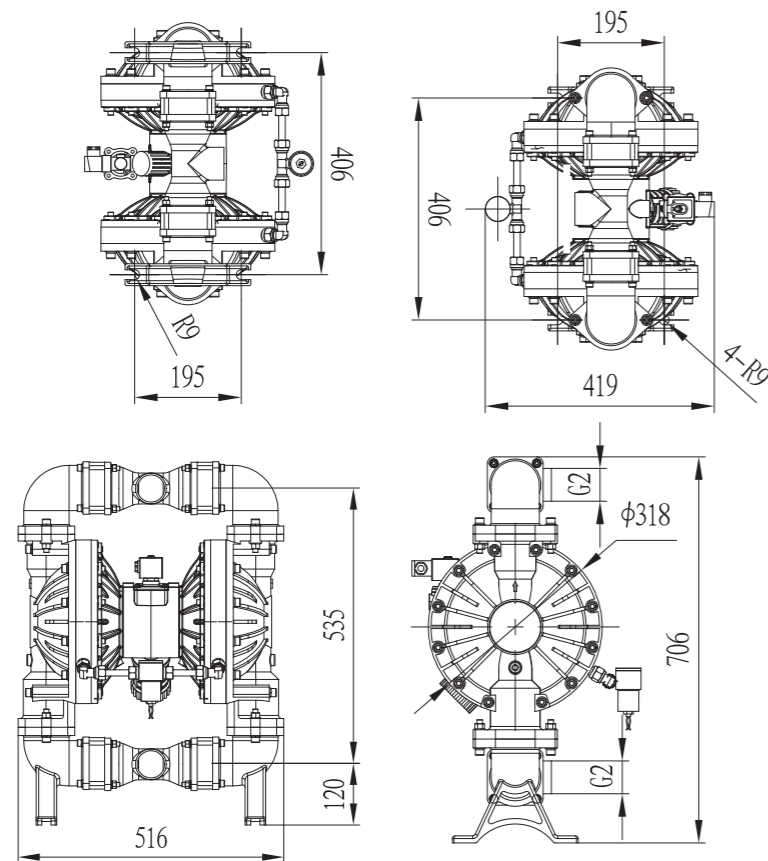

BFQJ-80 不锈钢/不锈钢316



性能曲线图

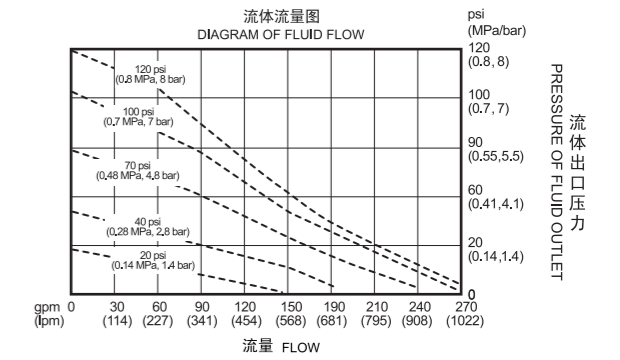

规格参数

最大工作流量 Max. Flow	275 gpm (1041 lpm)	最大虹吸高度 (干抽或湿抽) Max.Suction Height (dry suction or wet suction)	25 ft. (7.6 m)
最大工作压力 Max. Working Pressure	120 psi (0.84 Mpa, 8.4 bar)	最大输送固体颗粒 Max. Permitted Grain	82.6 scfm
流体进口尺寸 Fluid Inlet Size	3 in. bsp (f)	每往复流量 Every Reciprocating Flow	2.0 gal. (7.6 L)
流体出口尺寸 Fluid Outlet Size	3 in. bsp (f)	最大往复速度 Max. Reciprocating Speed	135 cpm
空气进口尺寸 Air Inlet Size	3/4 in. bsp (f)		

安装尺寸图

