

# 03

**BQG**

小灵通矿用  
气动隔膜泵



## BQG100/0.2 铝合金



### 性能曲线图

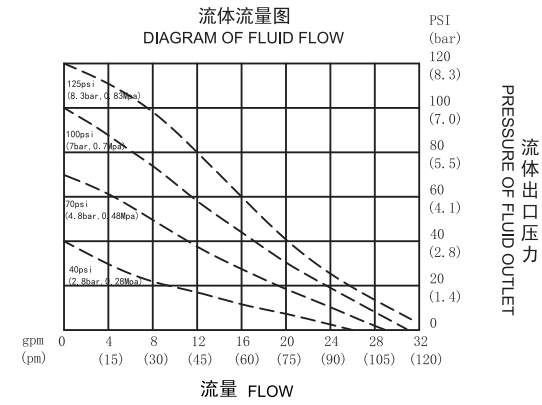

### 规格参数

额定流量 Rated flow	100 L/min	最大颗粒物直径 Max. Passing particle diameter	3.2 mm
额定排出压力 Outlet pressure	0.2 Mpa	管口螺纹规格	
工作气压 Rated air consumption	0.4-0.7 Mpa	Pipe opening thread specification	G1-11
吸程 Suction lift	4 m	进气口规格 Air inlet Specification	G1/2-14
额定供气压力 Rated gas supply Pressure	0.5 Mpa	耗气量 Gas consumption	≤1000 L/min

### 安装尺寸图

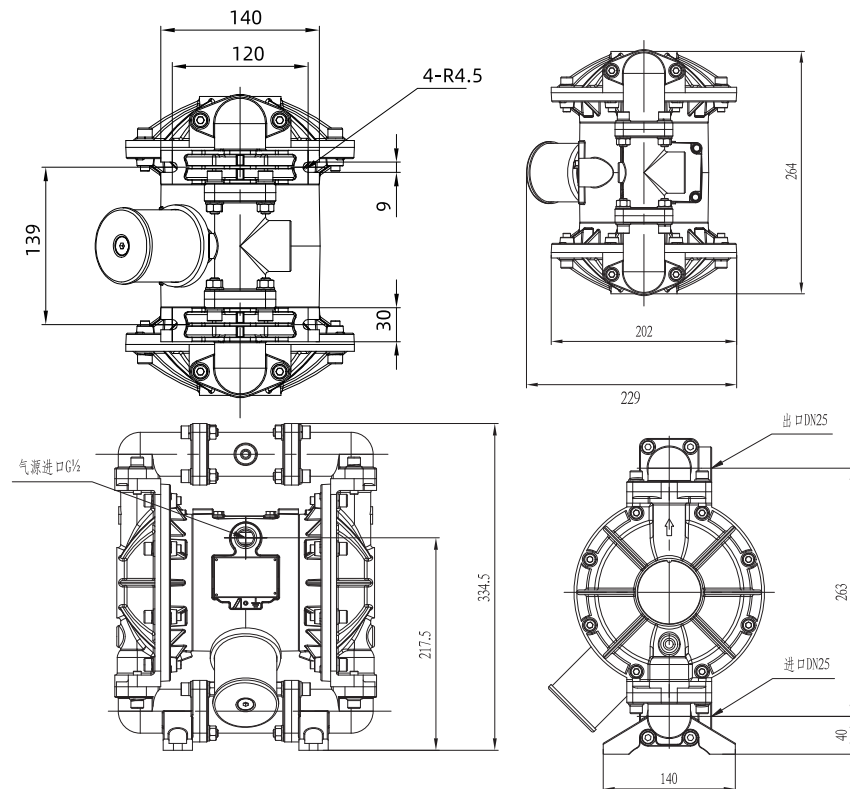

## BQG200/0.2 铝合金



### 性能曲线图

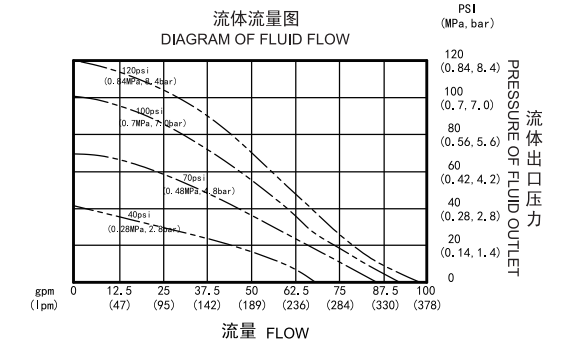

### 规格参数

额定流量 Rated flow	200 L/min	最大颗粒物直径 Max. Passing particle diameter	4.8 mm
额定排出压力 Outlet pressure	0.2 Mpa	管口螺纹规格	
工作气压 Rated air consumption	0.4-0.7 Mpa	Pipe opening thread specification	G1-11
吸程 Suction lift	5 m	进气口规格 Air inlet Specification	G1/2-14
额定供气压力 Rated gas supply Pressure	0.5 Mpa	耗气量 Gas consumption	≤1400 L/min

### 安装尺寸图

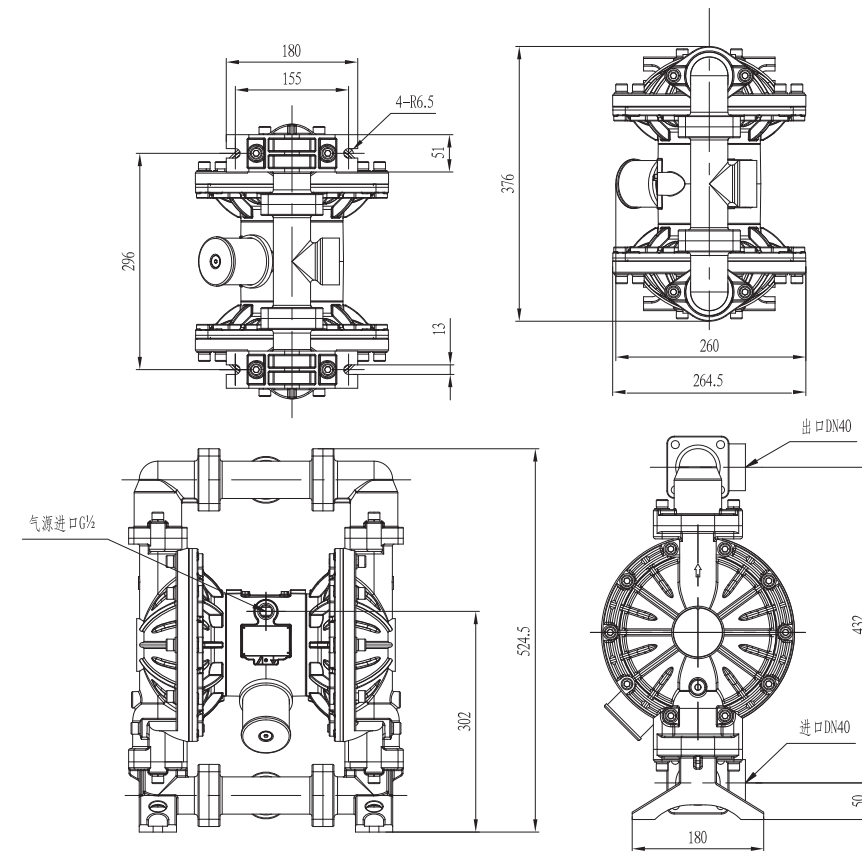

## BQG350/0.2 铝合金



### 性能曲线图

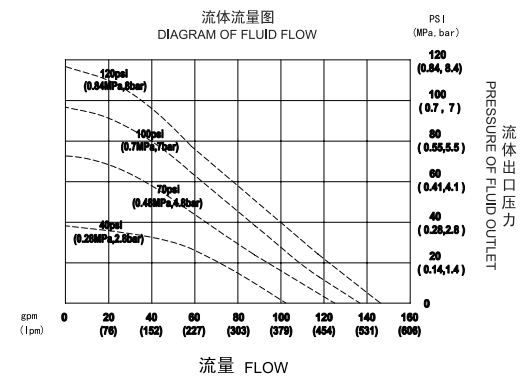

### 规格参数

额定流量 Rated flow	350 L/min
额定排出压力 Outlet pressure	0.2 Mpa
工作气压 Rated air consumption	0.4-0.7 Mpa
吸程 Suction lift	4 m
额定供气压力 Rated gas supply Pressure	0.5 Mpa

最大颗粒物直径 Max. Passing particle diameter	6.4 mm
管口螺纹规格	
Pipe opening thread specification	G2-11
进气口规格 Air inlet Specification	G1/2-14
耗气量 Gas consumption	≤1950 L/min

### 安装尺寸图

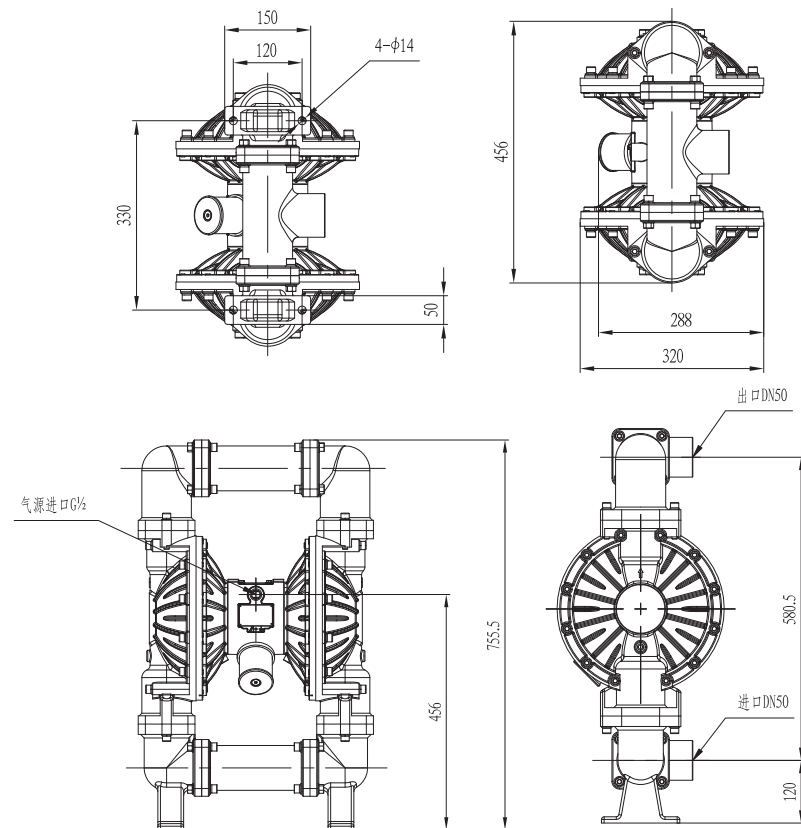

## BQG450/0.2 铝合金



### 性能曲线图

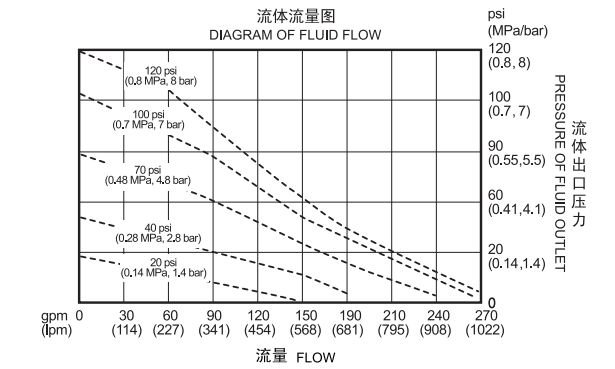

### 规格参数

额定流量 Rated flow	450 L/min
额定排出压力 Outlet pressure	0.2 Mpa
工作气压 Rated air consumption	0.4-0.7 Mpa
吸程 Suction lift	5 m
额定供气压力 Rated gas supply Pressure	0.5 Mpa

最大颗粒物直径 Max. Passing particle diameter	9.4mm
管口螺纹规格	
Pipe opening thread specification	DN80法兰
进气口规格 Air inlet Specification	G3/4-14
耗气量 Gas consumption	≤2400 L/min

### 安装尺寸图

