

# 目录

Directory



## 01

01 新能源锂电专用泵系列  
01 GDXQ  
05 GDXD  
09 GDXDA

## 02

11 大流量隔膜泵系列  
11 BFQ  
20 BFD  
28 BFQJ

## 03

31 小灵通矿用气动隔膜泵系列  
31 BQG

## 04

35 砂磨机专用泵A&O系列  
35 RA-25L

## 05

37 船用泵  
37 GDC

## 06

41 第三代隔膜泵系列  
41 QBY3  
55 DBY3

## 07

67 卫生泵系列  
67 QBW3  
71 DBW3

## 08

75 配件系列  
75 周边产品及配件  
77 周边产品  
  
78 泵系统图  
79 过流部件抗腐蚀性参数表

# 01

## GDXQ/D 新能源锂电专用泵



## GDXQ-25 不锈钢/塑料/氟塑料



### 性能曲线图

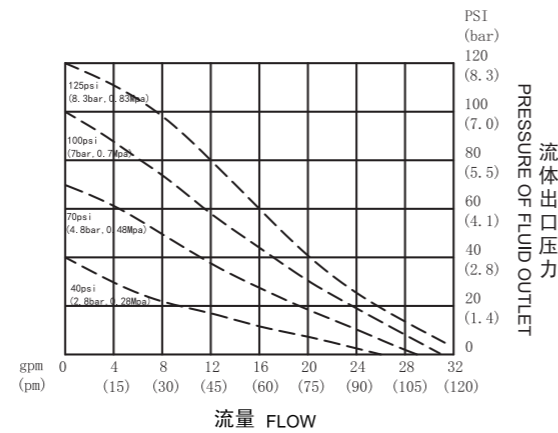

### 规格参数

最大工作流量 Max. Flow	31 gpm (116 lpm)	最大虹吸高度 (干抽或湿抽) Max. Suction Height (dry suction or wet suction)	18 ft. (5.48 m)
最大工作压力 Max. Working Pressure	120 psi (0.84 Mpa, 8.4 bar)	最大输送固体颗粒 Max. Permitted Grain	1/8 in. (3.2 mm)
流体进口尺寸 Fluid Inlet Size	1 in. bsp (f)	每往复流量 Every Reciprocating Flow	0.15 gal. (0.57 L)
流体出口尺寸 Fluid Outlet Size	1 in. bsp (f)	最大往复速度 Max. Reciprocating Speed	276 cpm
空气进口尺寸 Air Inlet Size	1/2 in. bsp (f)		

### 安装尺寸图

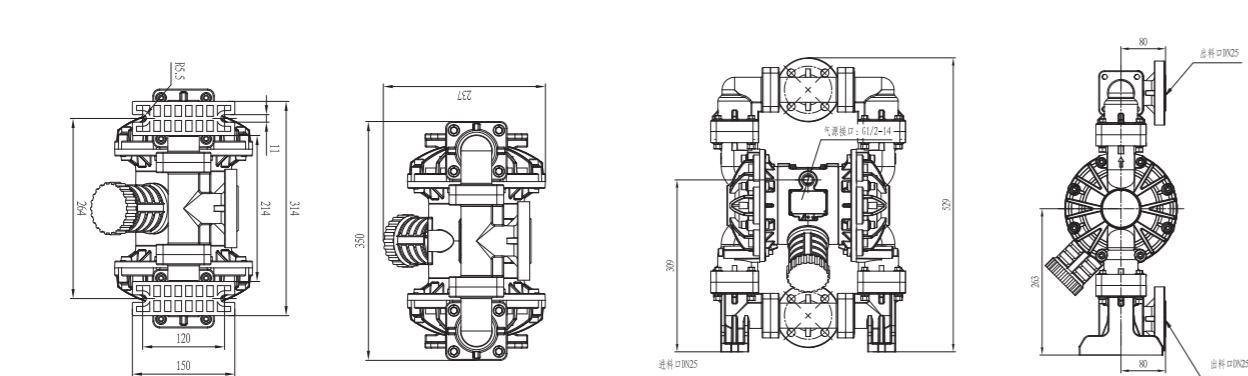
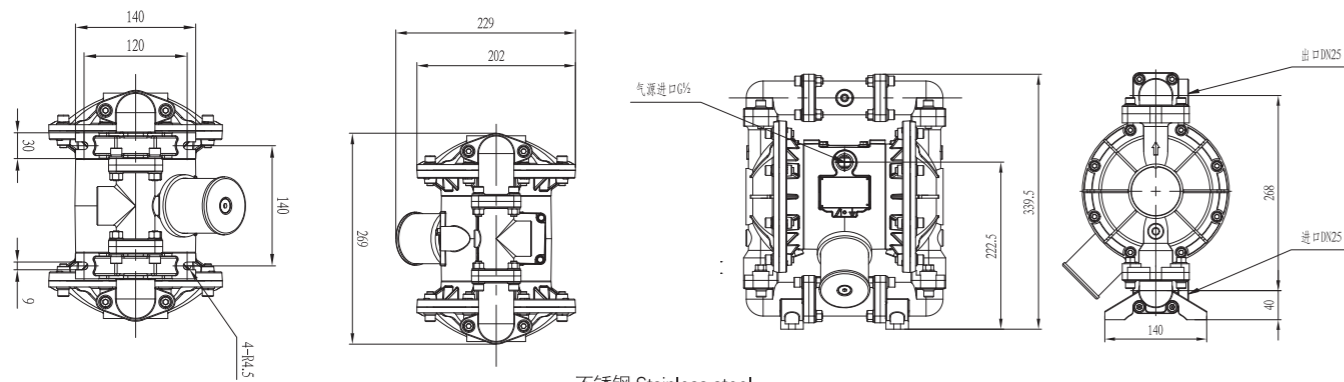

## GDXQ-40 不锈钢/塑料/氟塑料

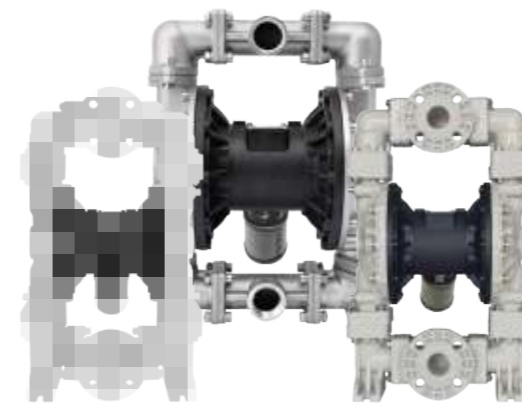

### 性能曲线图

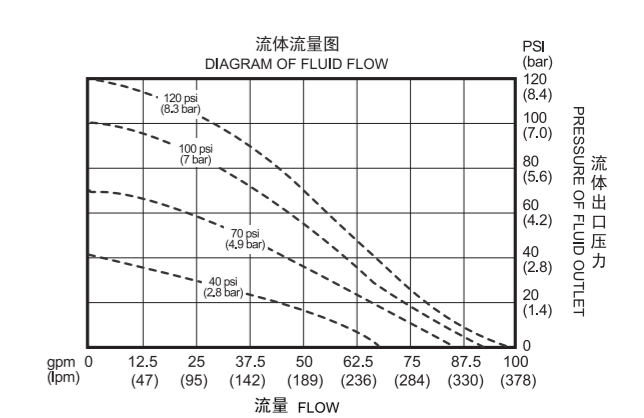

### 规格参数

最大工作流量 Max. Flow	100 gpm (378.5 lpm)	最大虹吸高度 (干抽或湿抽) Max. Suction Height (dry suction or wet suction)	18 ft. (5.48 m)
最大工作压力 Max. Working Pressure	120 psi (0.84 Mpa, 8.4 bar)	最大输送固体颗粒 Max. Permitted Grain	3/16 in. (4.8 mm)
流体进口尺寸 Fluid Inlet Size	1-1/2 in. bsp (f)	每往复流量 Every Reciprocating Flow	0.5 gal. (1.9 L)
流体出口尺寸 Fluid Outlet Size	1-1/2 in. bsp (f)	最大往复速度 Max. Reciprocating Speed	200 cpm
空气进口尺寸 Air Inlet Size	1/2 in. bsp (f)		

### 安装尺寸图

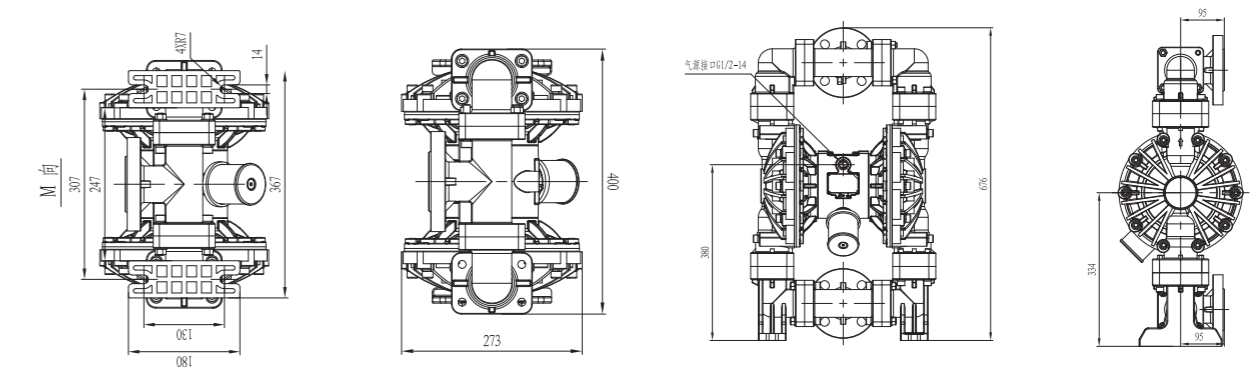
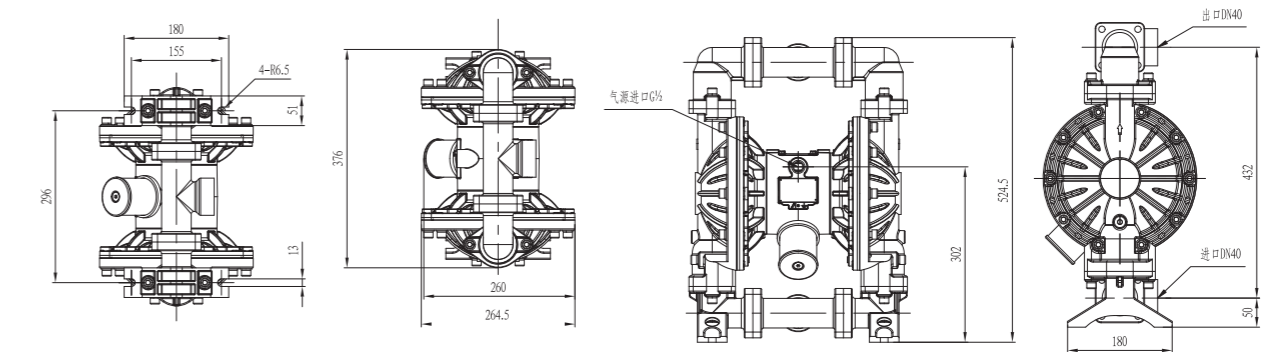

## GDXQ-50 不锈钢/塑料/氟塑料



### 性能曲线图

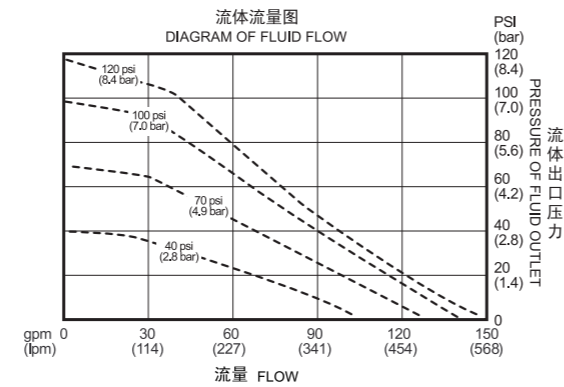

### 规格参数

最大工作流量 Max. Flow	150 gpm (568 lpm)	最大虹吸高度 (干抽或湿抽) Max.Suction Height (dry suction or wet suction)	18 ft. (5.48 m)
最大工作压力 Max. Working Pressure	120 psi (0.84 Mpa, 8.4 bar)	最大输送固体颗粒 Max. Permitted Grain	1/4 in. (6.4 mm)
流体进口尺寸 Fluid Inlet Size	2 in. bsp (f)	每往复流量 Every Reciprocating Flow	1.03 gal. (3.90 L)
流体出口尺寸 Fluid Outlet Size	2 in. bsp (f)	最大往复速度 Max. Reciprocating Speed	145 cpm
空气进口尺寸 Air Inlet Size	1/2 in. bsp (f)		

### 安装尺寸图

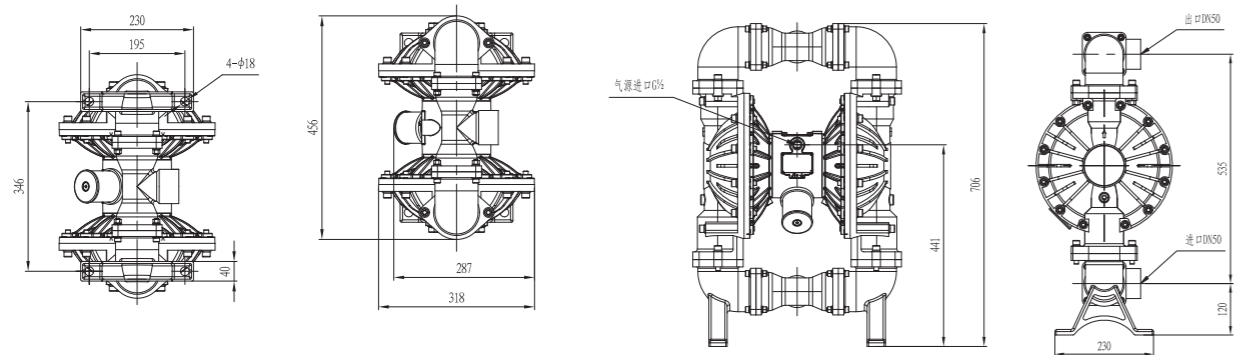

不锈钢 Stainless steel

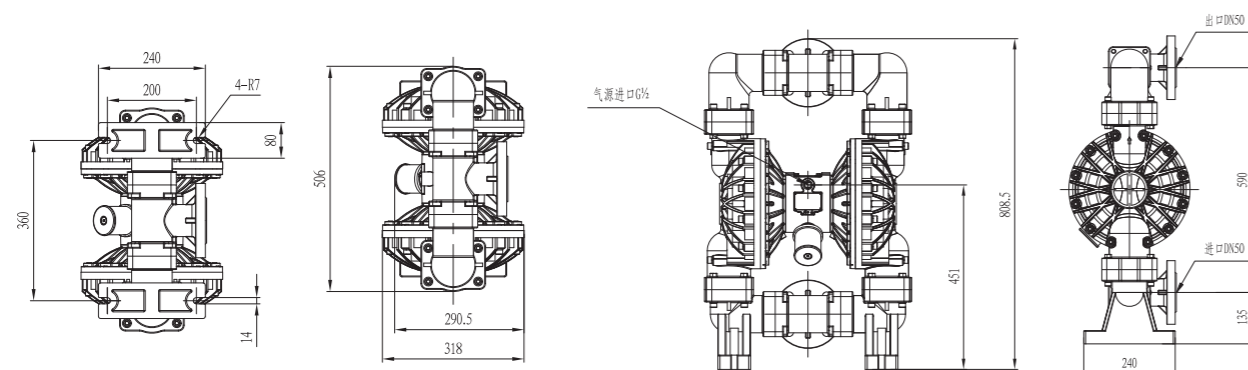

塑料/氟塑料 PP/PVDF

## GDXQ-80 不锈钢/塑料/氟塑料



### 性能曲线图

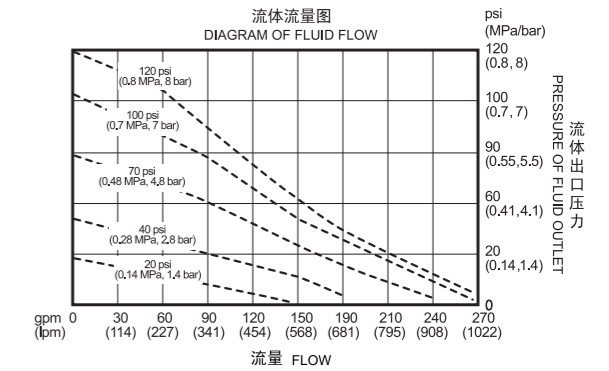

### 规格参数

最大工作流量 Max. Flow	275 gpm (1041 lpm)	最大虹吸高度 (干抽或湿抽) Max.Suction Height (dry suction or wet suction)	25 ft. (7.6 m)
最大工作压力 Max. Working Pressure	120 psi (0.84 Mpa, 8.4 bar)	最大输送固体颗粒 Max. Permitted Grain	3/8 in. ( 9.4 mm)
流体进口尺寸 Fluid Inlet Size	3 in. bsp (f)	每往复流量 Every Reciprocating Flow	2.0 gal. (7.6 L)
流体出口尺寸 Fluid Outlet Size	3 in. bsp (f)	最大往复速度 Max. Reciprocating Speed	135 cpm
空气进口尺寸 Air Inlet Size	3/4 in. bsp (f)		

### 安装尺寸图

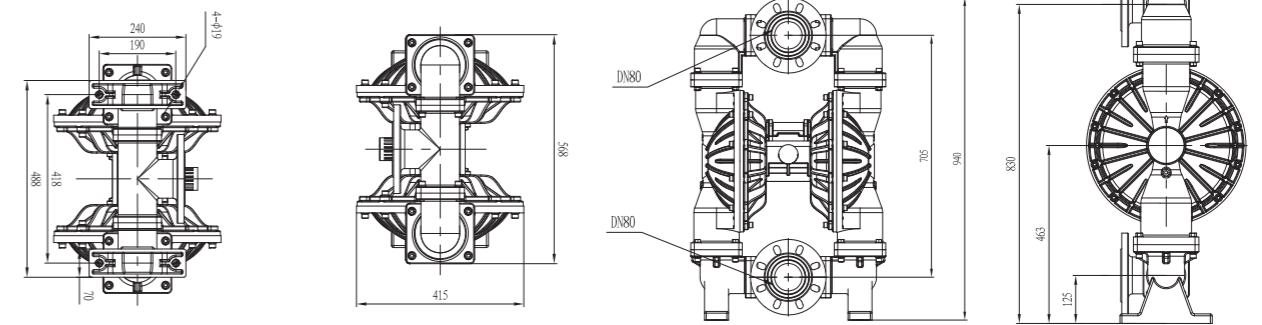

不锈钢 Stainless steel

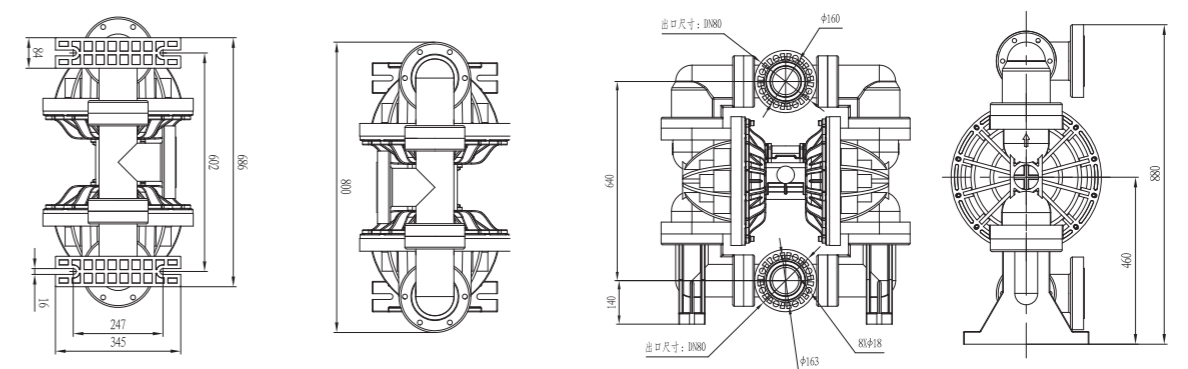

塑料/氟塑料 PP/PVDF

## GDXD-25 不锈钢/塑料/氟塑料



### 性能曲线图

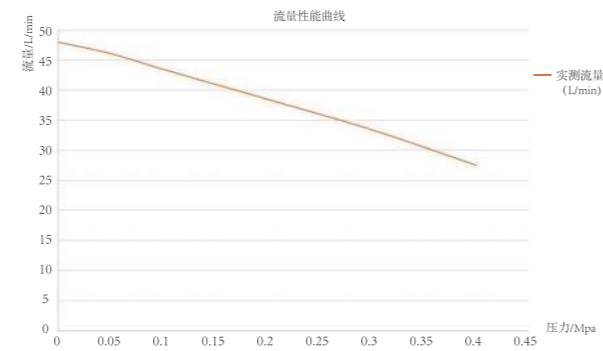

### 规格参数

最大工作流量 Max.Flow	12.7gpm ( 48Lpm )	最大输送固体颗粒 Max.Permitted Grain	1/8in.(3.2mm)
最大工作压力 Max.Working Pressure	0.4Mpa / 0.7Mpa	每往复流量 Every Reciprocating Flow	0.15gallon(0.57L)
流体进口尺寸 Fluid Inlet Size	1in.bsp ( f )	最大往复速度 Max.Reciprocating Speed	85cpm
流体出口尺寸 Fluid Outlet Size	1in.bsp ( f )	出口压力 Outlet Pressure	0.4Mpa / 0.7Mpa
最大虹吸高度(干抽或湿抽)		电机功率 Motor power	1.5kw / 2.2kw
Max.Suction height(dry suction or wet suction)	13ft.(4m )		

### 安装尺寸图

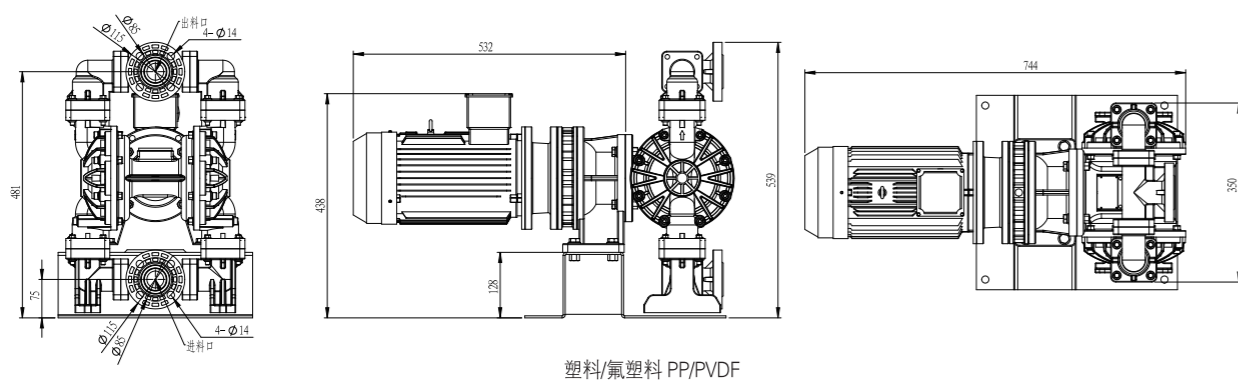
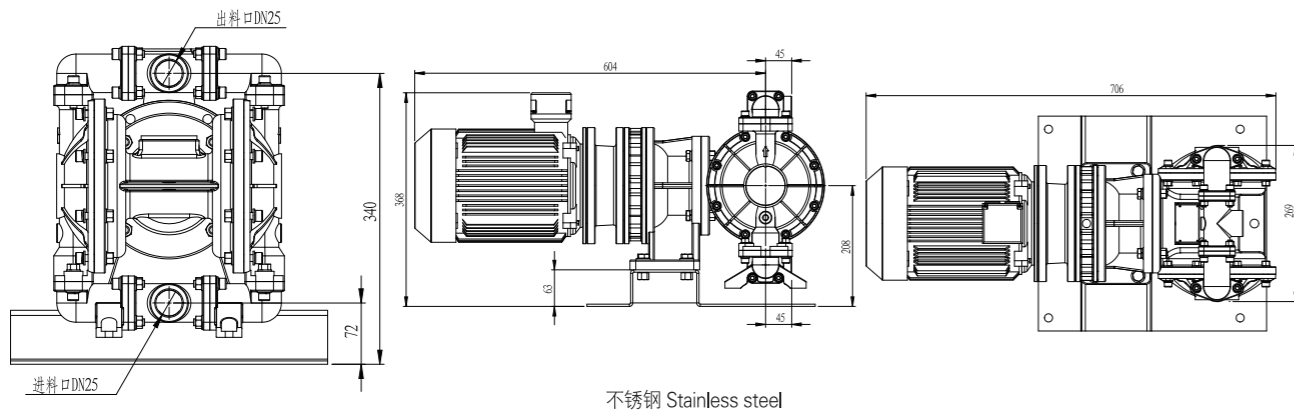

## GDXD-40 不锈钢/塑料/氟塑料



### 性能曲线图

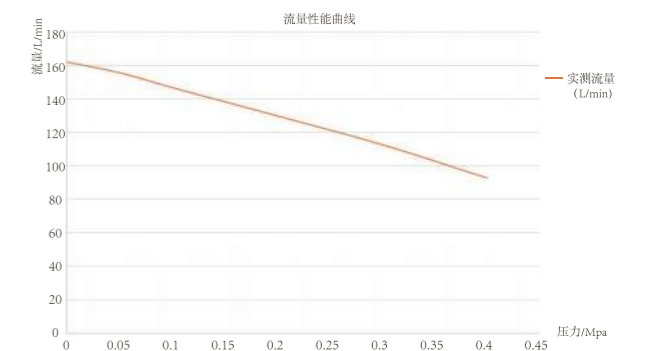

### 规格参数

最大工作流量 Max.Flow	42.8gpm ( 162lpm )	最大输送固体颗粒 Max.Permitted Grain	3/16in.(4.8mm)
最大工作压力 Max.Working Pressure	0.4Mpa / 0.7Mpa	每往复流量 Every Reciprocating Flow	0.5gallon(1.9L)
流体进口尺寸 Fluid Inlet Size	1-1/2in.bsp ( f )	最大往复速度 Max.Reciprocating Speed	85cpm
流体出口尺寸 Fluid Outlet Size	1-1/2in.bsp ( f )	出口压力 Outlet Pressure	0.4Mpa / 0.7Mpa
最大虹吸高度(干抽或湿抽)		电机功率 Motor power	2.2kw / 3kw
Max.Suction height(dry suction or wet suction)	16.4ft.(5m )		

### 安装尺寸图

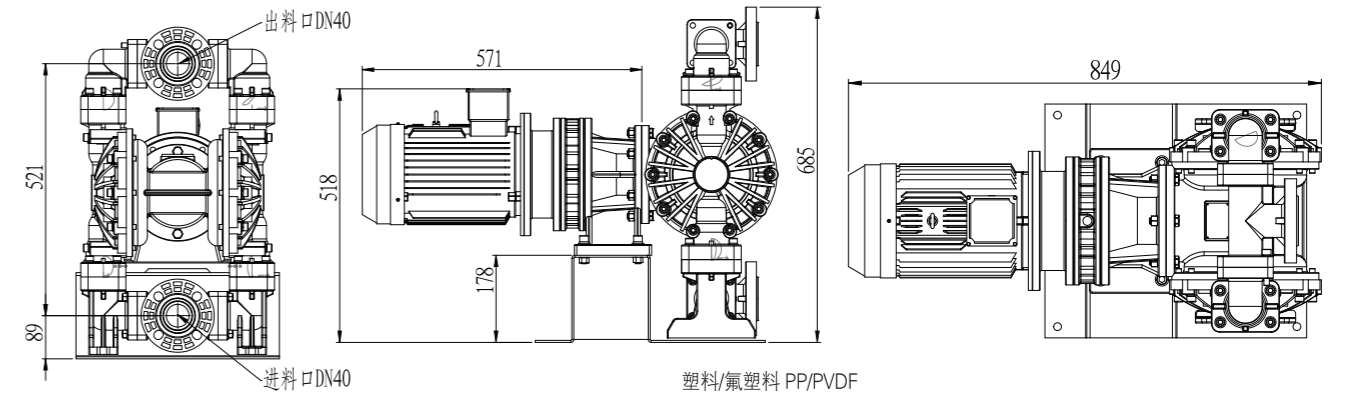
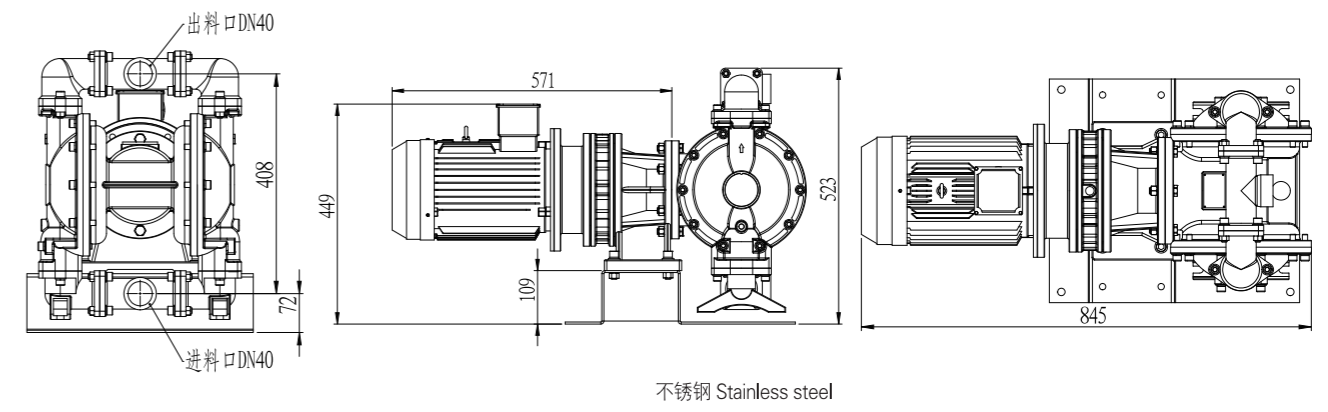

## GDXD-50 不锈钢/塑料/氟塑料

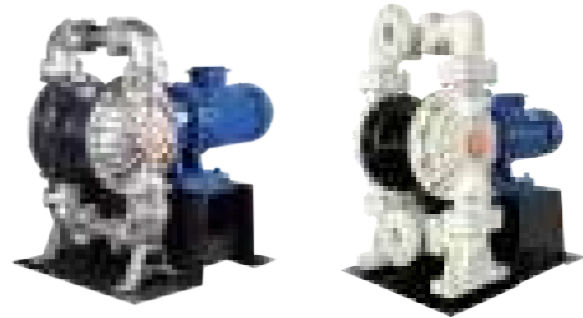

### 性能曲线图

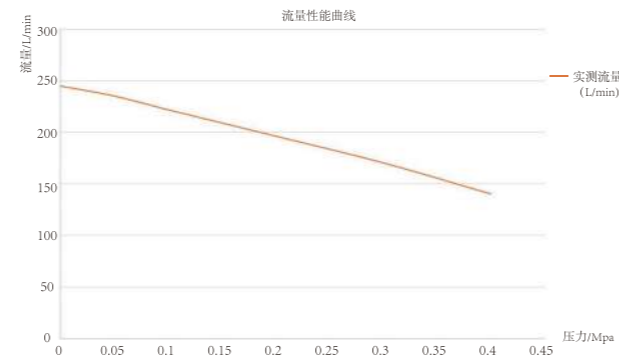

### 规格参数

最大工作流量 Max.Flow	64.7gpm ( 245lpm )	最大输送固体颗粒 Max.Permitted Grain	1/4in.(6.4mm)
最大工作压力 Max.Working Pressure	0.4Mpa / 0.7Mpa	每往复流量 Every Reciprocating Flow	1.03gallon(3.9L)
流体进口尺寸 Fluid Inlet Size	2in.bsp ( f )	最大往复速度 Max.Reciprocating Speed	63cpm
流体出口尺寸 Fluid Outlet Size	2in.bsp ( f )	出口压力 Outlet Pressure	0.4Mpa / 0.7Mpa
最大虹吸高度(干抽或湿抽)		电机功率 Motor power	3kw / 4kw
Max.Suction height(dry suction or wet suction)	16.4ft.(5m )		

### 安装尺寸图

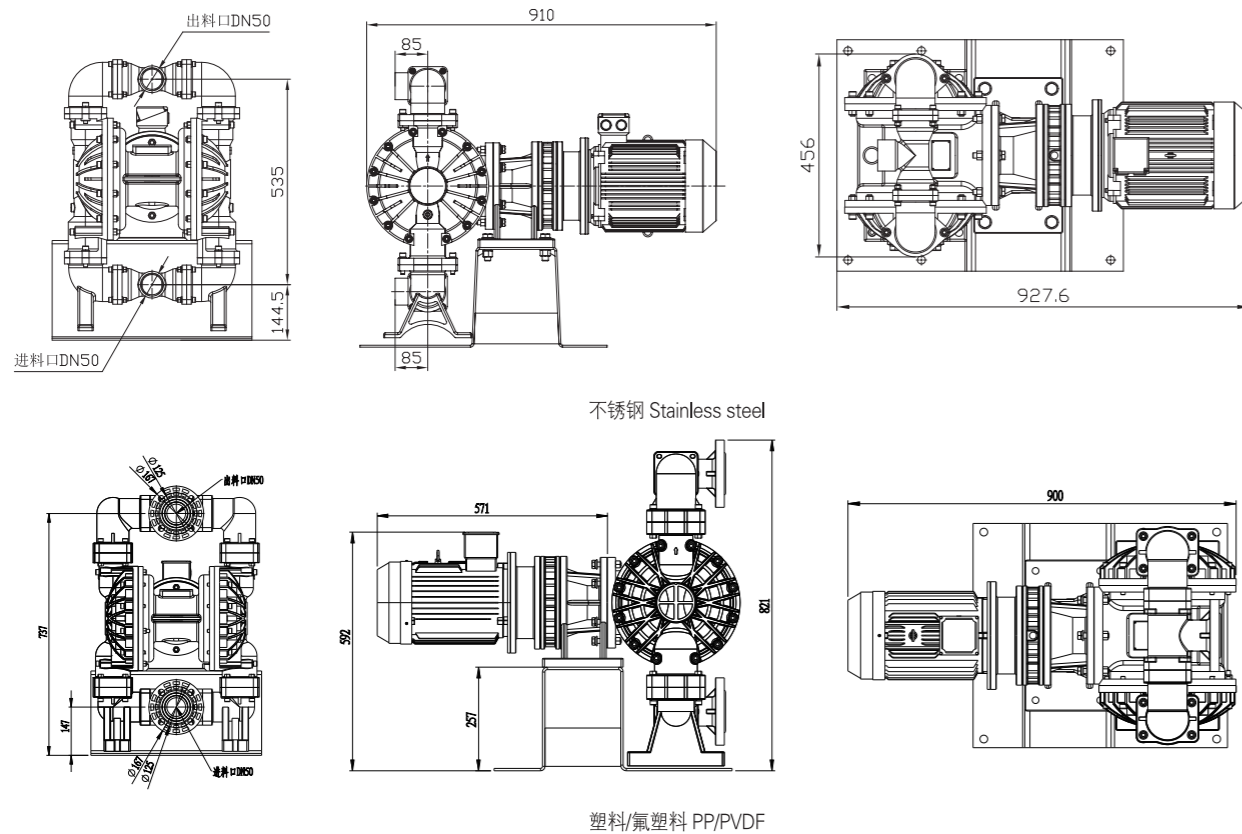

## GDXD-80 不锈钢/塑料/氟塑料



### 性能曲线图

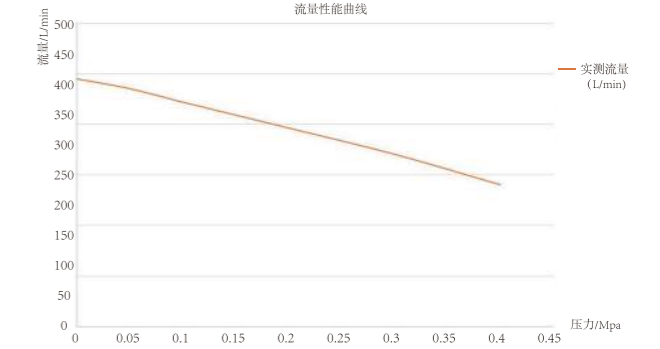

### 规格参数

最大工作流量 Max.Flow	26.8gpm ( 480Lpm )	最大输送固体颗粒 Max.Permitted Grain	3/8in.(9.4mm)
最大工作压力 Max.Working Pressure	0.4Mpa / 0.7Mpa	每往复流量 Every Reciprocating Flow	2.0gallon(7.6L)
流体进口尺寸 Fluid Inlet Size	3in.bsp ( f )	最大往复速度 Max.Reciprocating Speed	63cpm
流体出口尺寸 Fluid Outlet Size	3in.bsp ( f )	出口压力 Outlet Pressure	0.4Mpa / 0.7Mpa
最大虹吸高度(干抽或湿抽)		电机功率 Motor power	4kw / 5.5kw
Max.Suction height(dry suction or wet suction)	20ft.(6m )		

### 安装尺寸图

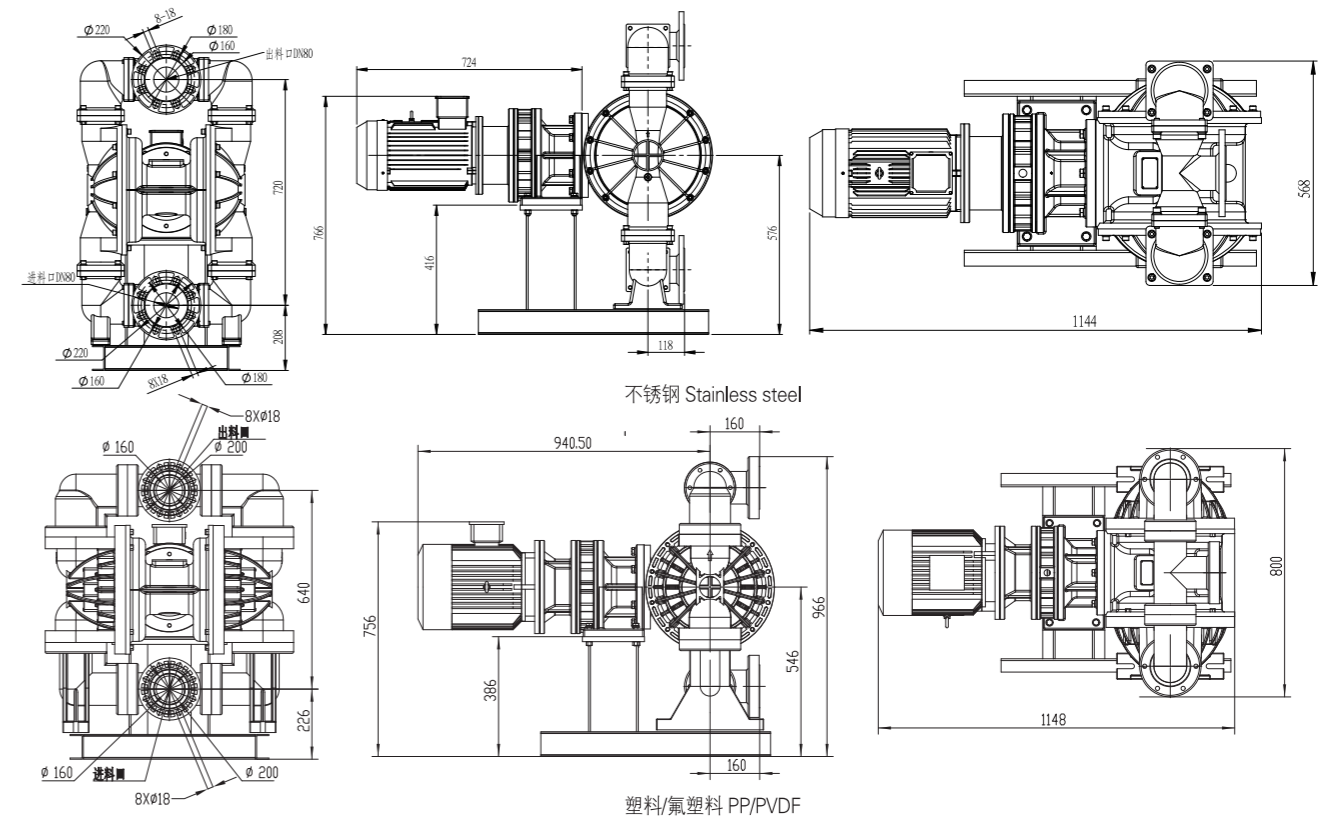

## GDXDA-50 不锈钢304/316L



### 性能曲线图

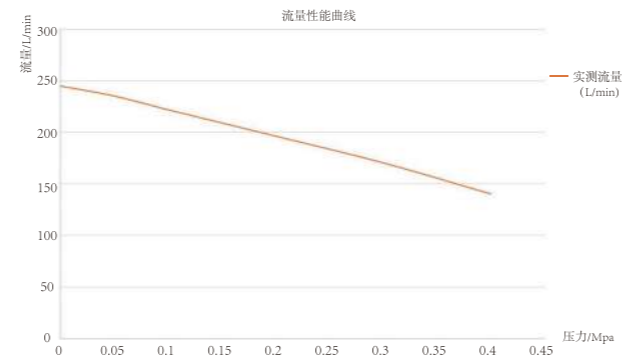

### 规格参数

最大工作流量 Max.Flow	64.7gpm ( 245lpm )	每往复流量 Every Reciprocating Flow	2.0gallon(7.6L)
最大工作压力 Max.Working Pressure	58psi ( 0.4Mpa, 4bar )	最大往复速度 Max.Reciprocating Speed	63cpm
最大虹吸高度(干抽或湿抽)		出口压力 Outlet Pressure	0.4Mpa
Max.Suction height(dry suction or wet suction)	16.4ft.(5m )	电机功率 Motor power	3kw
最大输送固体颗粒Max.Permitted Grain	1/4in.(6.4mm)		

### 安装尺寸图

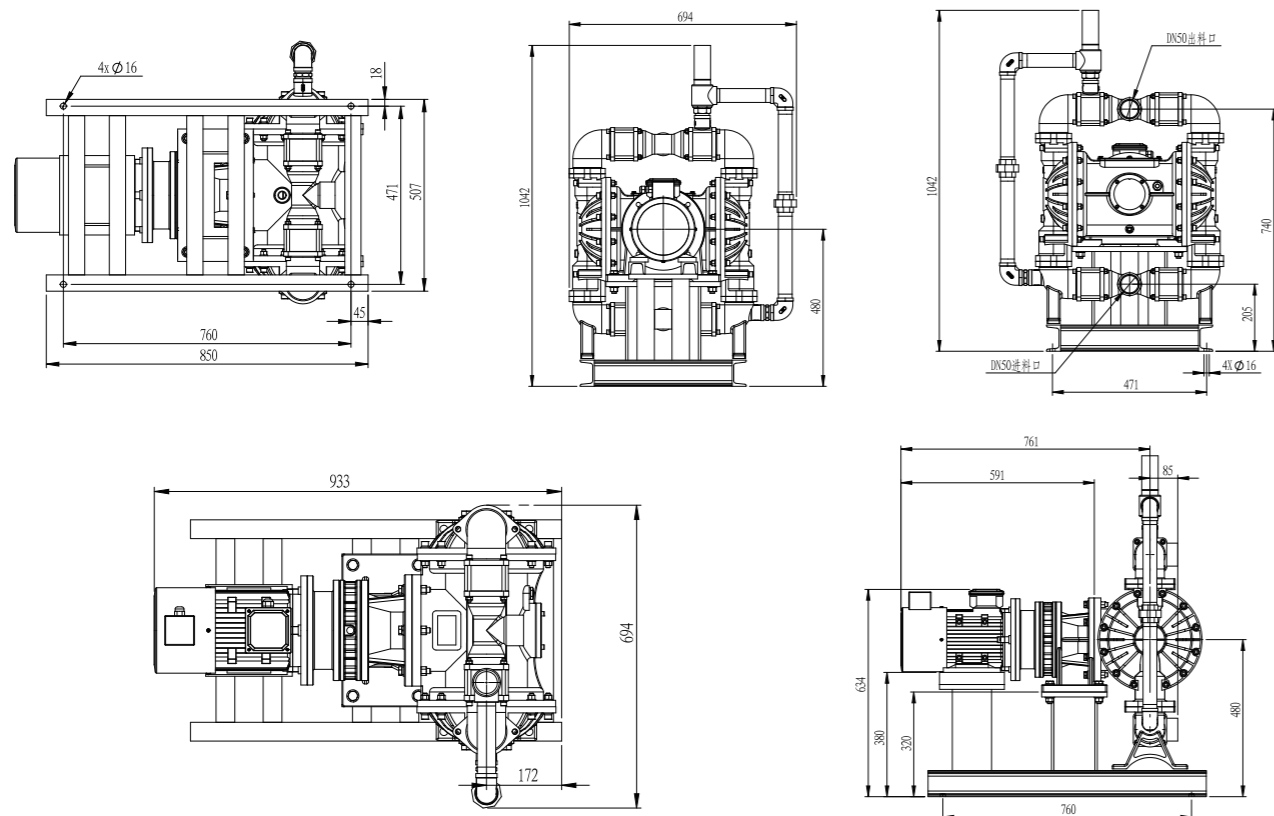

## GDXDA-80 不锈钢304/316L



### 性能曲线图

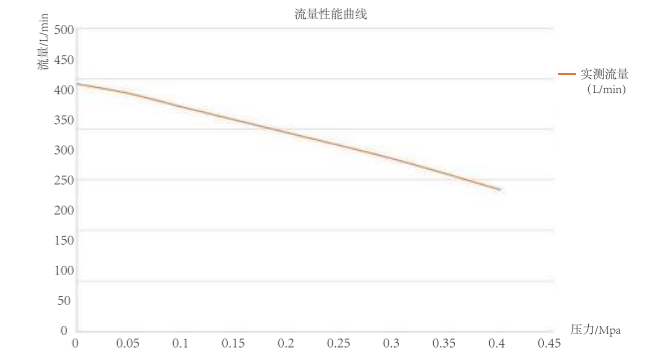

### 规格参数

最大工作流量 Max.Flow	126.8gpm ( 480Lpm )	每往复流量 Every Reciprocating Flow	2.0gallon(7.6L)
最大工作压力 Max.Working Pressure	58psi ( 0.4Mpa, 4bar )	最大往复速度 Max.Reciprocating Speed	63cpm
最大虹吸高度(干抽或湿抽)		出口压力 Outlet Pressure	0.4Mpa
Max.Suction height(dry suction or wet suction)	16.4ft.(5m )	电机功率 Motor power	4kw
最大输送固体颗粒Max.Permitted Grain	3/8in.(9.4mm)		

### 安装尺寸图

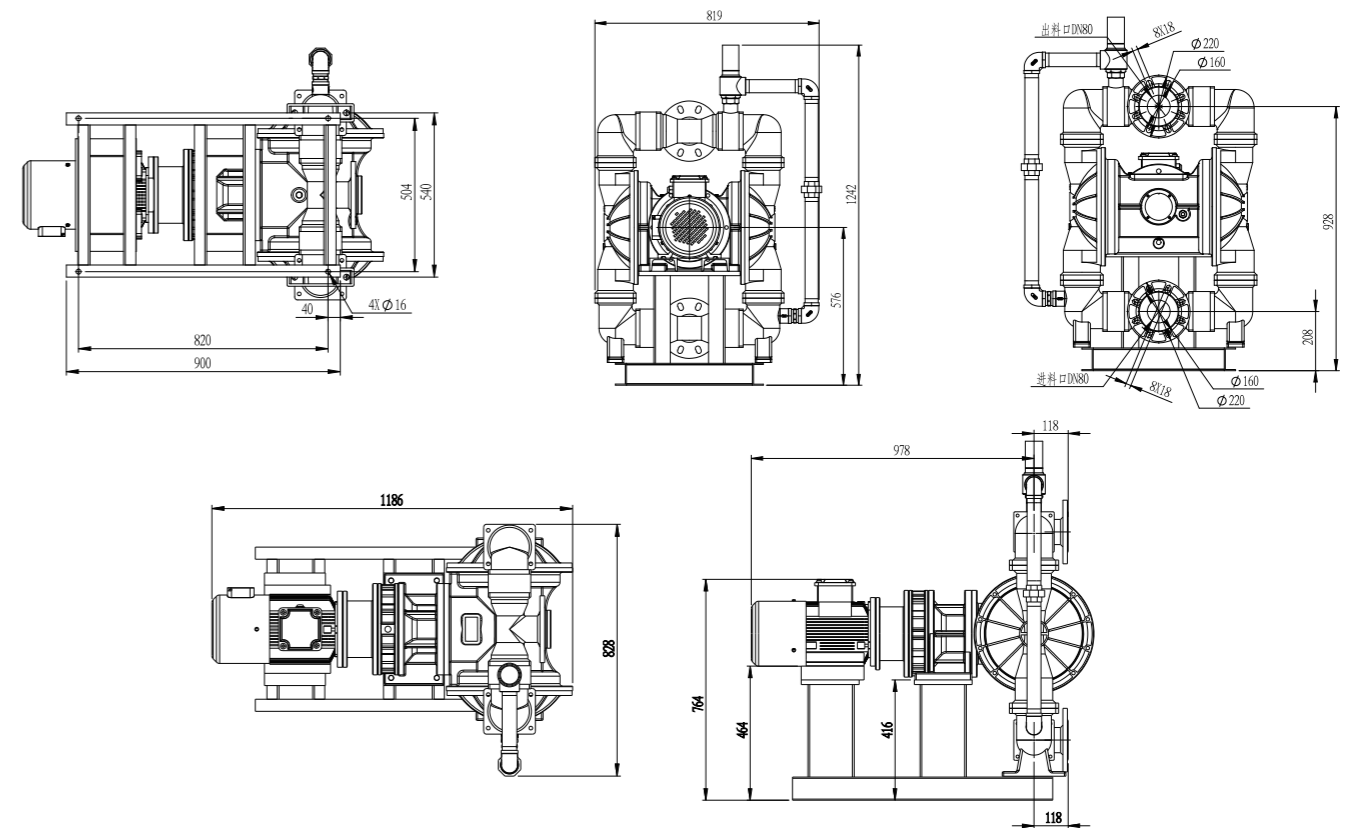

# 02

## BFQ/D 大流量隔膜泵



## BFQ-25 铝合金/不锈钢/铸钢



### 性能曲线图

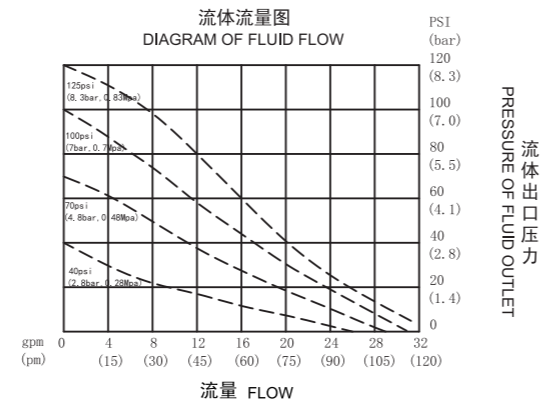

### 规格参数

最大工作流量 Max. Flow	31 gpm (116 lpm)	最大虹吸高度 (干抽或湿抽) Max.Suction Height (dry suction or wet suction)	18 ft. (5.48 m)
最大工作压力 Max. Working Pressure	120 psi (0.84 Mpa, 8.4 bar)	最大输送固体颗粒 Max. Permitted Grain	1/8 in. (3.2 mm)
流体进口尺寸 Fluid Inlet Size	1 in. bsp (f)	每往复流量 Every Reciprocating Flow	0.15 gal. (0.57 L)
流体出口尺寸 Fluid Outlet Size	1 in. bsp (f)	最大往复速度 Max. Reciprocating Speed	276 cpm
空气进口尺寸 Air Inlet Size	1/2 in. bsp (f)		

### 安装尺寸图

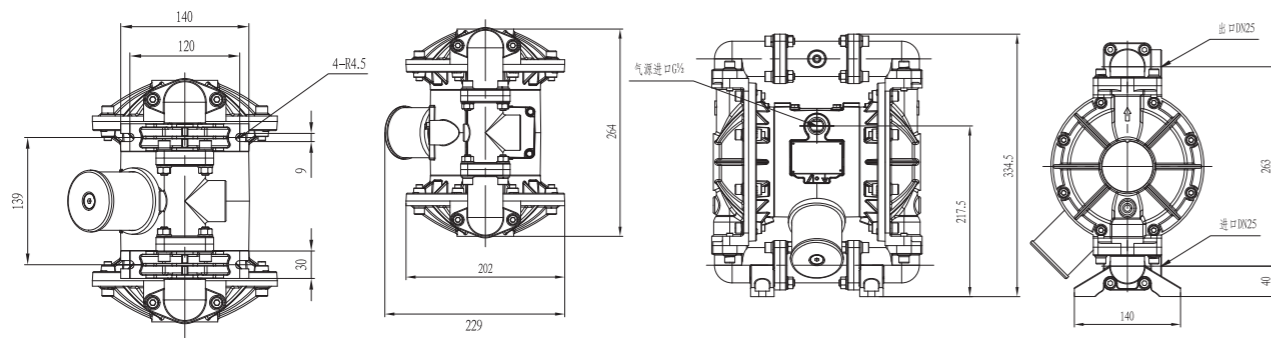

铝合金 Aluminum alloy

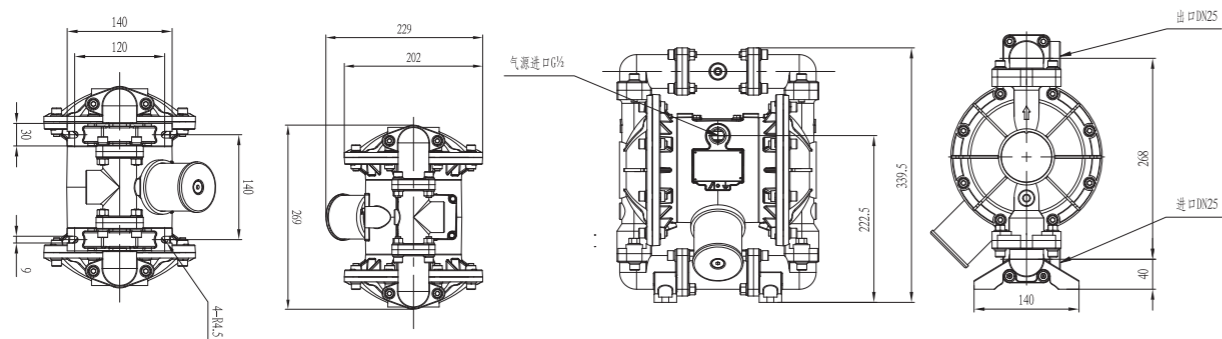

不锈钢/铸钢 Stainless steel/Cast steel

## BFQ-25 塑料/氟塑料/衬氟



### 性能曲线图

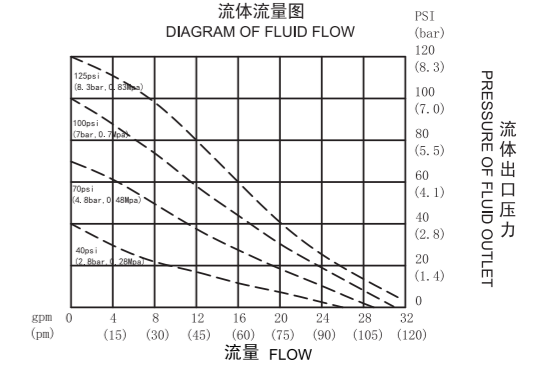

### 规格参数

最大工作流量 Max. Flow	31 gpm (116 lpm)	最大虹吸高度 (干抽或湿抽) Max.Suction Height (dry suction or wet suction)	18 ft. (5.48 m)
最大工作压力 Max. Working Pressure	120 psi (0.84 Mpa, 8.4 bar)	最大输送固体颗粒 Max. Permitted Grain	1/8 in. (3.2 mm)
流体进口尺寸 Fluid Inlet Size	1 in. bsp (f)	每往复流量 Every Reciprocating Flow	0.15 gal. (0.57 L)
流体出口尺寸 Fluid Outlet Size	1 in. bsp (f)	最大往复速度 Max. Reciprocating Speed	276 cpm
空气进口尺寸 Air Inlet Size	1/2 in. bsp (f)		

### 安装尺寸图

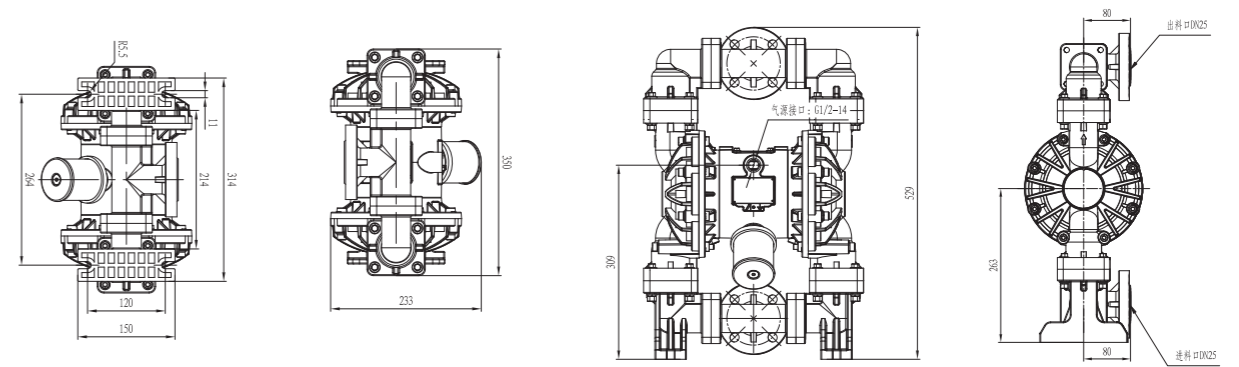

塑料/氟塑料 PP/PVDF

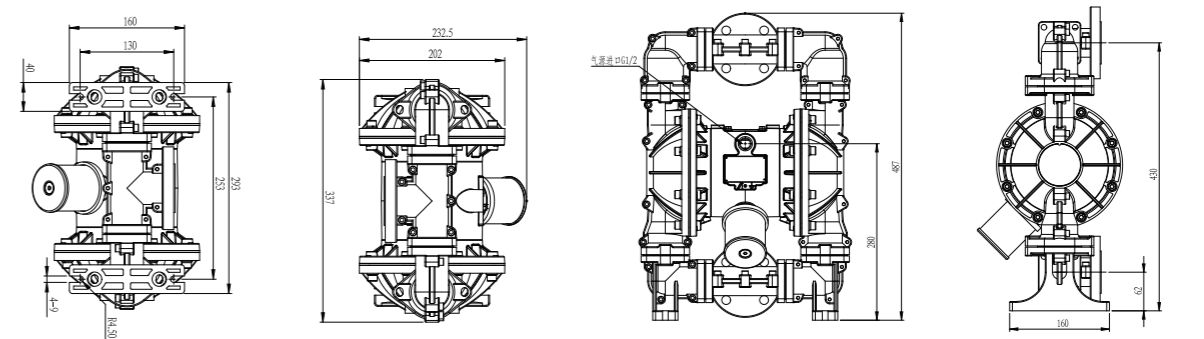

衬氟 Lining PVDF

## BFQ-40 铝合金/不锈钢/球铁



### 性能曲线图

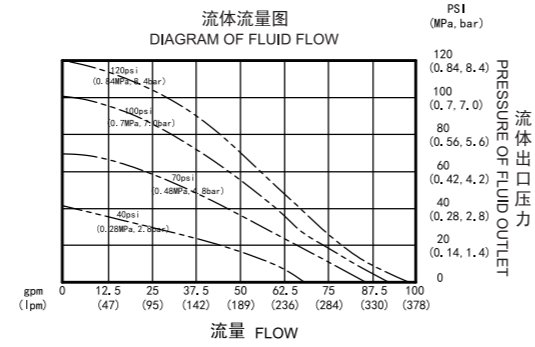

### 规格参数

最大工作流量 Max. Flow	100 gpm (378.5 lpm)	最大虹吸高度 (干抽或湿抽) Max. Suction Height (dry suction or wet suction)	18 ft. (5.48 m)
最大工作压力 Max. Working Pressure	120 psi (0.84 Mpa, 8.4 bar)	最大输送固体颗粒 Max. Permitted Grain	3/16 in. (4.8 mm)
流体进口尺寸 Fluid Inlet Size	1-1/2 in. bsp (f)	每往复流量 Every Reciprocating Flow	0.5 gal. (1.9 L)
流体出口尺寸 Fluid Outlet Size	1-1/2 in. bsp (f)	最大往复速度 Max. Reciprocating Speed	200 cpm
空气进口尺寸 Air Inlet Size	1/2 in. bsp (f)		

### 安装尺寸图

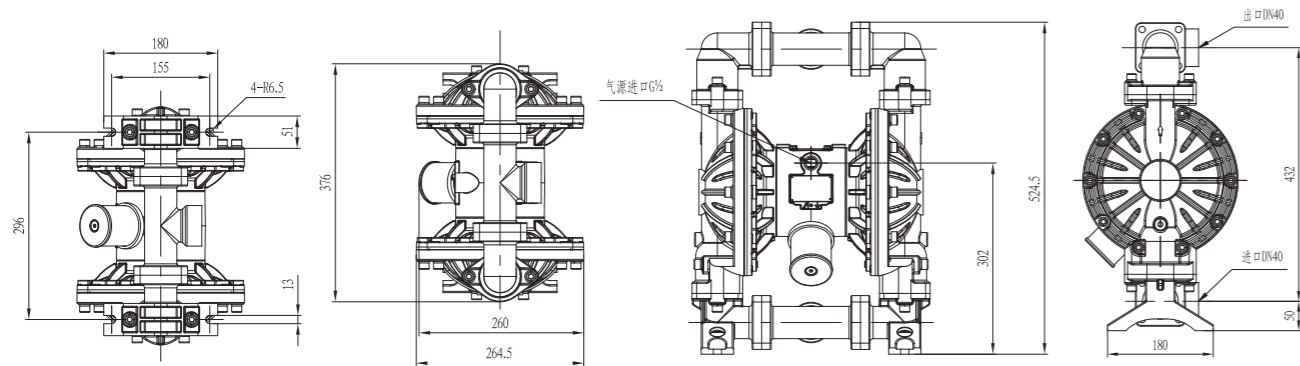

铝合金 Aluminum alloy

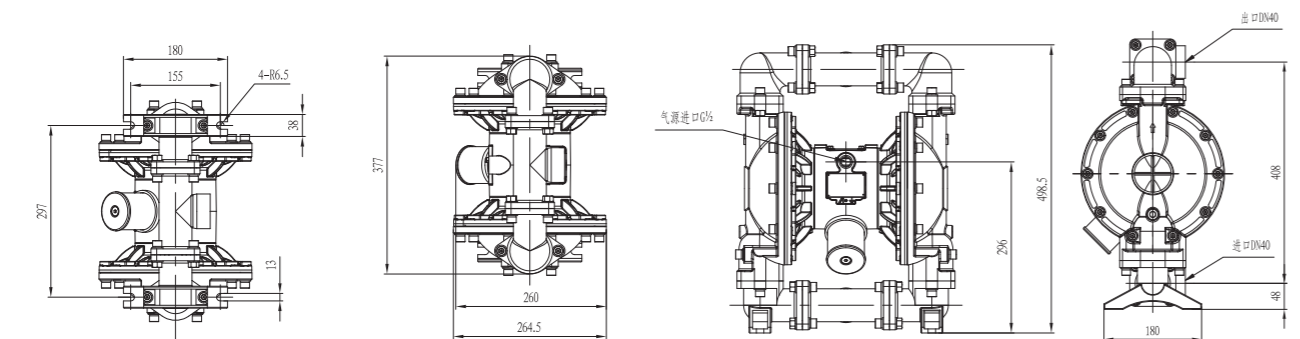

不锈钢/球铁 Stainless steel/Nodular cast iron

## BFQ-40 塑料/氟塑料/衬氟



### 性能曲线图

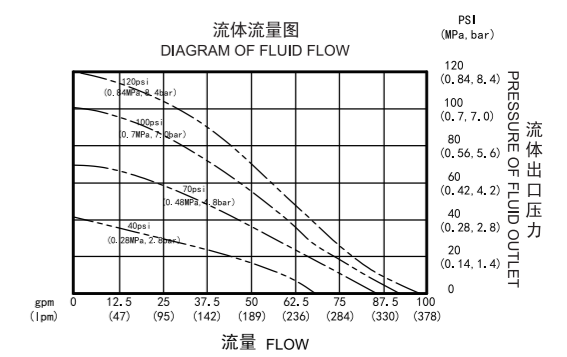

### 规格参数

最大工作流量 Max. Flow	100 gpm (378.5 lpm)	最大虹吸高度 (干抽或湿抽) Max. Suction Height (dry suction or wet suction)	18 ft. (5.48 m)
最大工作压力 Max. Working Pressure	120 psi (0.84 Mpa, 8.4 bar)	最大输送固体颗粒 Max. Permitted Grain	3/16 in. (4.8 mm)
流体进口尺寸 Fluid Inlet Size	1-1/2 in. bsp (f)	每往复流量 Every Reciprocating Flow	0.5 gal. (1.9 L)
流体出口尺寸 Fluid Outlet Size	1-1/2 in. bsp (f)	最大往复速度 Max. Reciprocating Speed	200 cpm
空气进口尺寸 Air Inlet Size	1/2 in. bsp (f)		

### 安装尺寸图

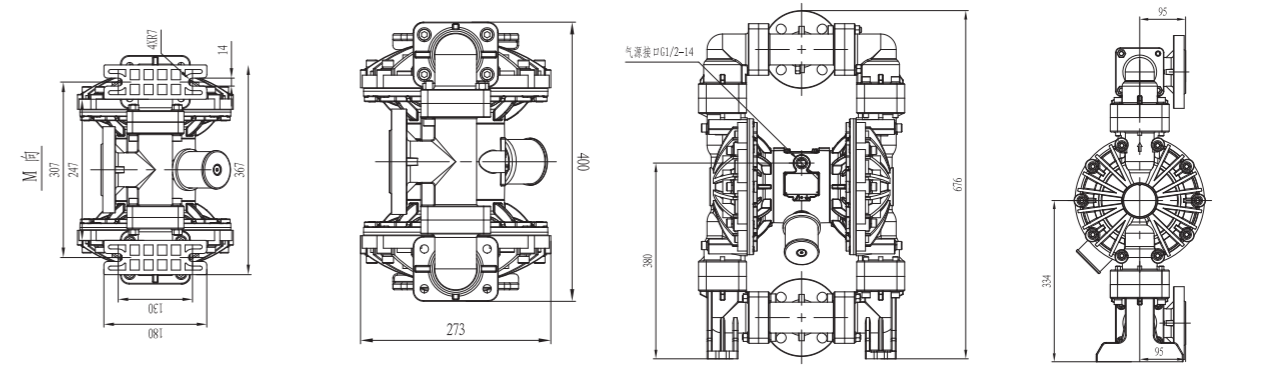

塑料/氟塑料 PP/PVDF

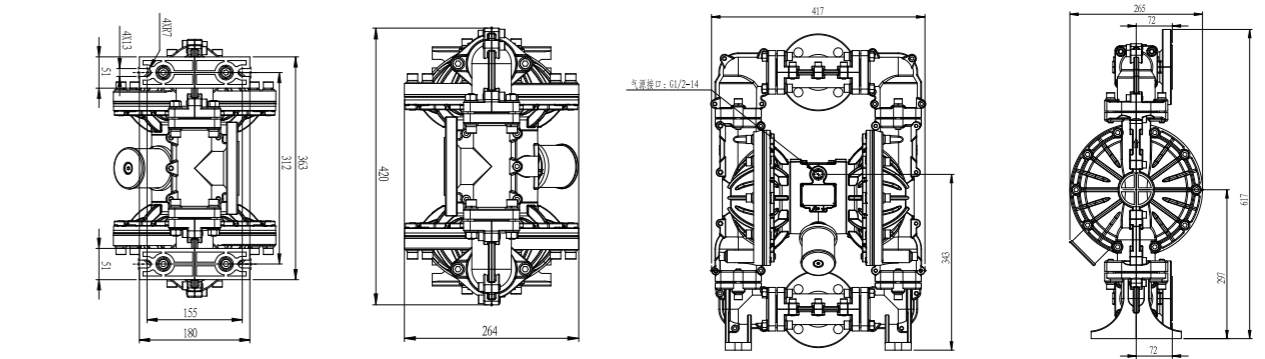

衬氟Lining PVDF

## BFQ-50 铝合金/不锈钢/球铁



### 性能曲线图

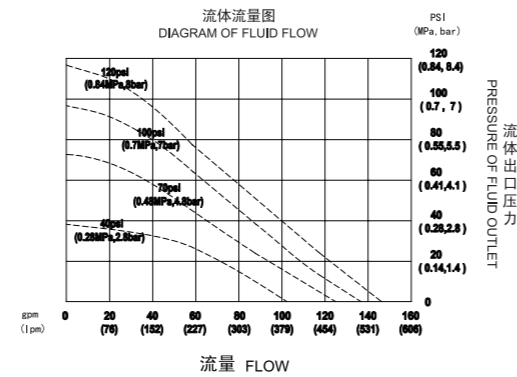

### 规格参数

最大工作量 Max. Flow	150 gpm (568 lpm)	最大虹吸高度 (干抽或湿抽) Max. Suction Height (dry suction or wet suction)	18 ft. (5.48 m)
最大工作压力 Max. Working Pressure	120 psi (0.84 Mpa, 8.4 bar)	最大输送固体颗粒 Max. Permitted Grain	1/4 in. (6.4 mm)
流体进口尺寸 Fluid Inlet Size	2 in. bsp (f)	每往复流量 Every Reciprocating Flow	1.03 gal. (3.90 L)
流体出口尺寸 Fluid Outlet Size	2 in. bsp (f)	最大往复速度 Max. Reciprocating Speed	145 cpm
空气进口尺寸 Air Inlet Size	1/2 in. bsp (f)		

### 安装尺寸图

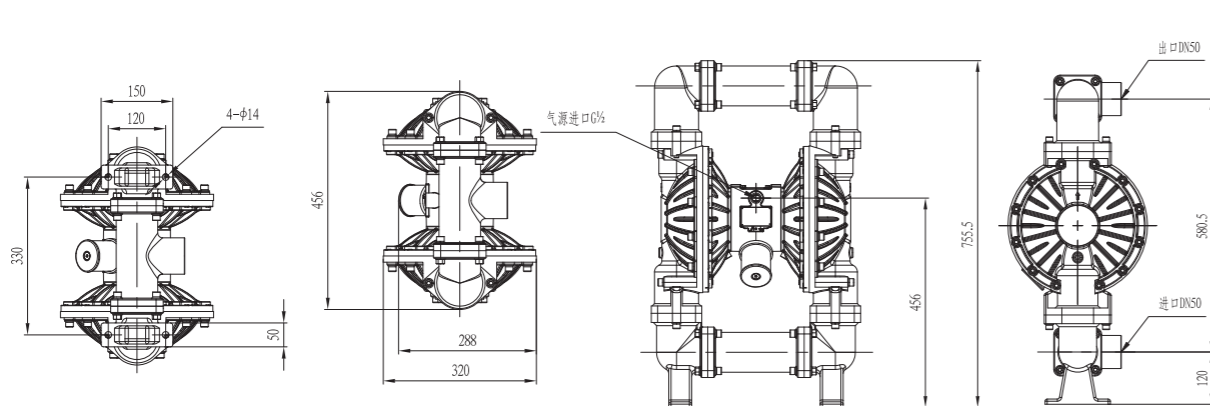

铝合金 Aluminum alloy

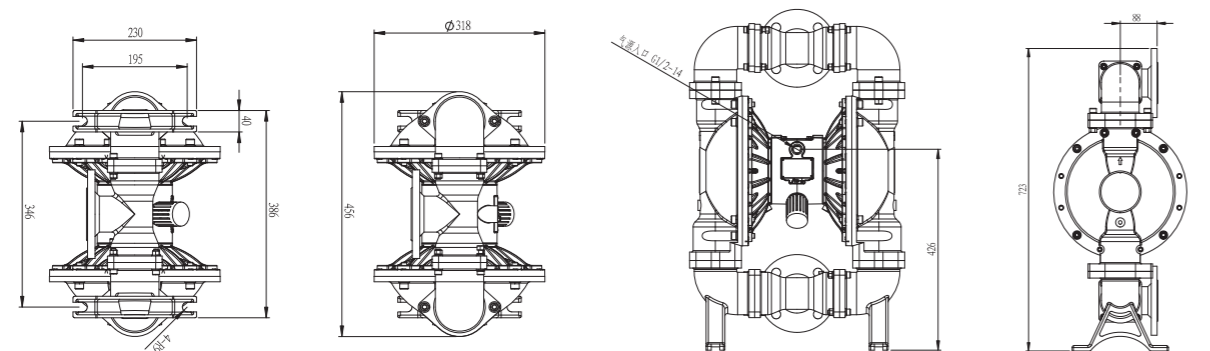

不锈钢/球铁 Stainless steel/Nodular cast iron

## BFQ-50 塑料/氟塑料/衬氟



### 性能曲线图

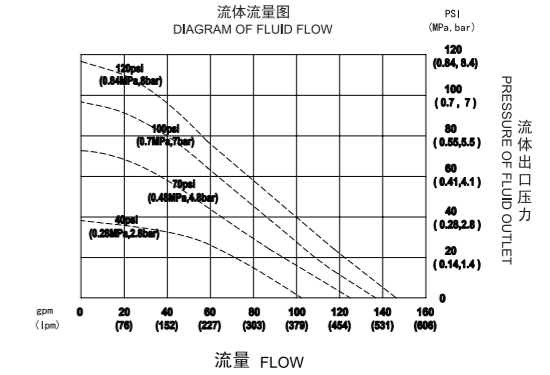

### 规格参数

最大工作量 Max. Flow	150 gpm (568 lpm)	最大虹吸高度 (干抽或湿抽) Max. Suction Height (dry suction or wet suction)	18 ft. (5.48 m)
最大工作压力 Max. Working Pressure	120 psi (0.84 Mpa, 8.4 bar)	最大输送固体颗粒 Max. Permitted Grain	1/4 in. (6.4 mm)
流体进口尺寸 Fluid Inlet Size	2 in. bsp (f)	每往复流量 Every Reciprocating Flow	1.03 gal. (3.90 L)
流体出口尺寸 Fluid Outlet Size	2 in. bsp (f)	最大往复速度 Max. Reciprocating Speed	145 cpm
空气进口尺寸 Air Inlet Size	1/2 in. bsp (f)		

### 安装尺寸图

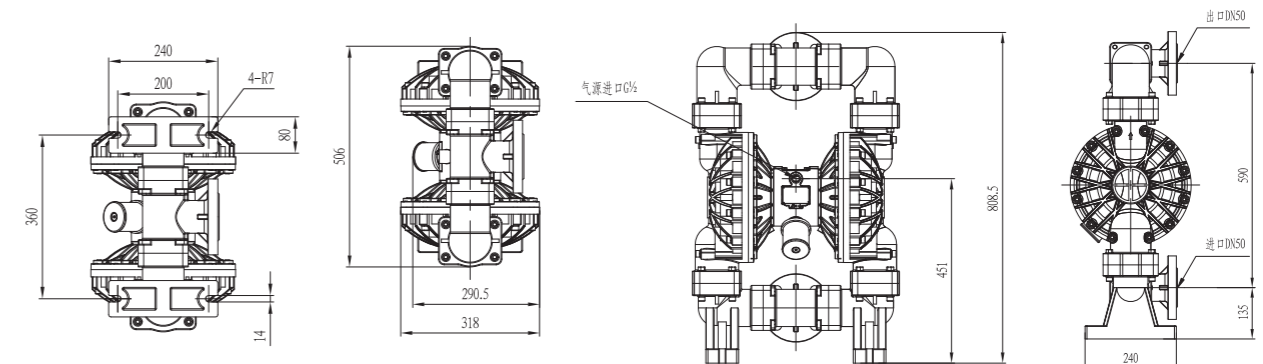

塑料/氟塑料 PP/PVDF

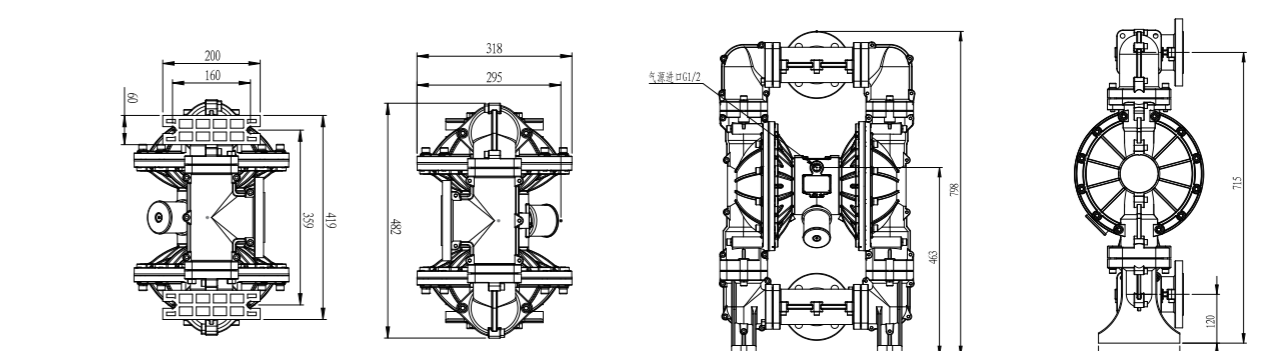

衬氟 Lining PVDF

## BFQ-80 铝合金/不锈钢/球铁



### 性能曲线图

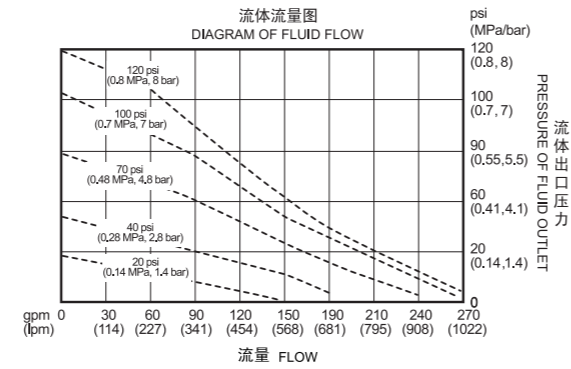

### 规格参数

最大工作流量 Max. Flow	275 gpm (1041 lpm)
最大工作压力 Max. Working Pressure	120 psi (0.84 Mpa, 8.4 bar)
流体进口尺寸 Fluid Inlet Size	3 in. bsp (f)
流体出口尺寸 Fluid Outlet Size	3 in. bsp (f)
空气进口尺寸 Air Inlet Size	3/4 in. bsp (f)

最大虹吸高度 (干抽或湿抽) Max.Suction Height (dry suction or wet suction)	25 ft. (7.6 m)
最大输送固体颗粒 Max. Permitted Grain	3/8 in. ( 9.4 mm )
每往复流量 Every Reciprocating Flow	2.0 gal. (7.6 L)
最大往复速度 Max. Reciprocating Speed	135 cpm

### 安装尺寸图

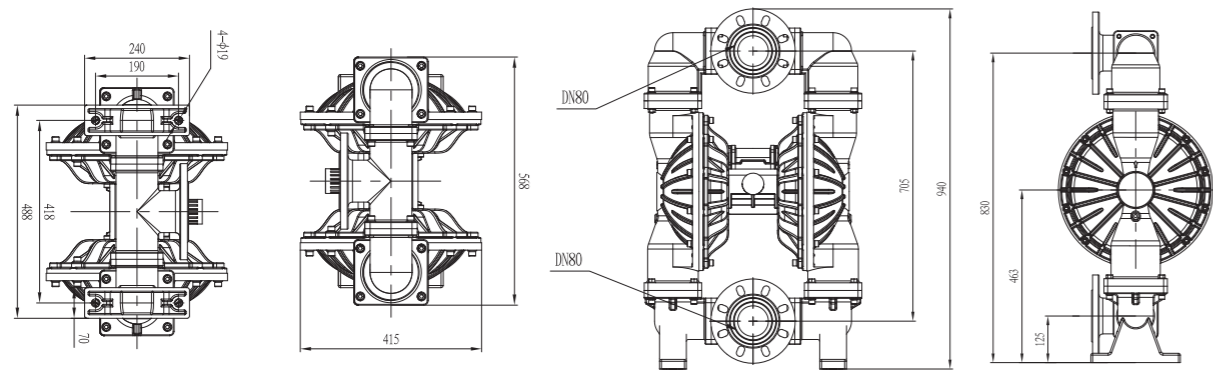

铝合金 Aluminum alloy

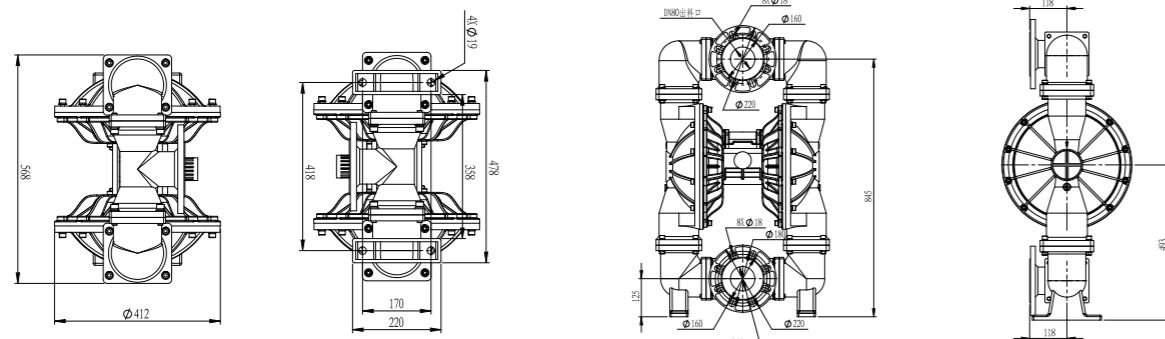

不锈钢/球铁 Stainless steel/Nodular cast iron

## BFQ-80 塑料/氟塑料/衬氟

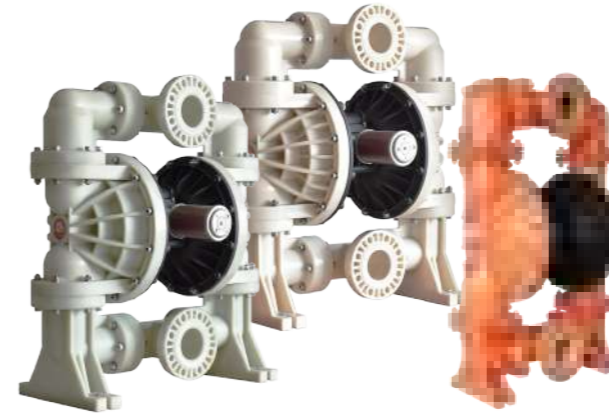

### 性能曲线图

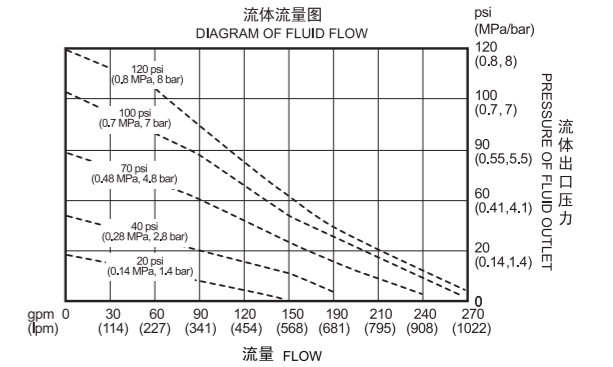

### 规格参数

最大工作流量 Max. Flow	275 gpm (1041 lpm)
最大工作压力 Max. Working Pressure	120 psi (0.84 Mpa, 8.4 bar)
流体进口尺寸 Fluid Inlet Size	3 in. bsp (f)
流体出口尺寸 Fluid Outlet Size	3 in. bsp (f)
空气进口尺寸 Air Inlet Size	3/4 in. bsp (f)

最大虹吸高度 (干抽或湿抽) Max.Suction Height (dry suction or wet suction)	25 ft. (7.6 m)
最大输送固体颗粒 Max. Permitted Grain	3/8 in. ( 9.4 mm )
每往复流量 Every Reciprocating Flow	2.0 gal. (7.6 L)
最大往复速度 Max. Reciprocating Speed	135 cpm

### 安装尺寸图

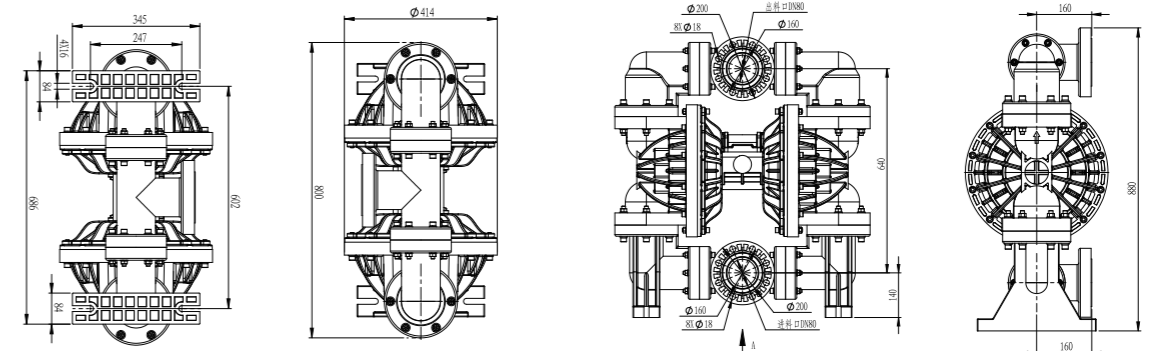

塑料/氟塑料 PP/PVDF

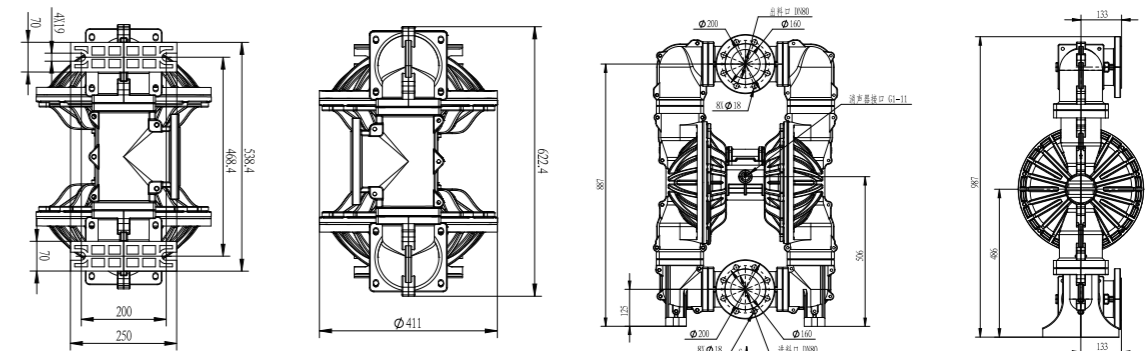

衬氟Lining PVDF

## BFQ-125 不锈钢304



### 性能曲线图

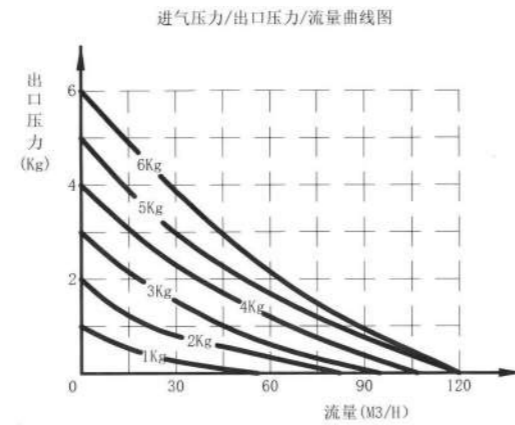

### 规格参数

最大工作流量 Max. Flow	528 gpm (2000 lpm)	最大虹吸高度 (干抽或湿抽)	
最大工作压力 Max. Working Pressure	90PSI	Max.Suction Height (dry suction or wet suction)	13 ft. (4 m)
流体进口尺寸 Fluid Inlet Size	DN125法兰	最大输送固体颗粒 Max. Permitted Grain	3/8 in. (9.4 mm)
流体出口尺寸 Fluid Outlet Size	DN125法兰	每往复流量 Every Reciprocating Flow	3.77gal/14L
空气进口尺寸 Air Inlet Size	G1-11	最大往复速度 Max. Reciprocating Speed	140 cpm

### 安装尺寸图

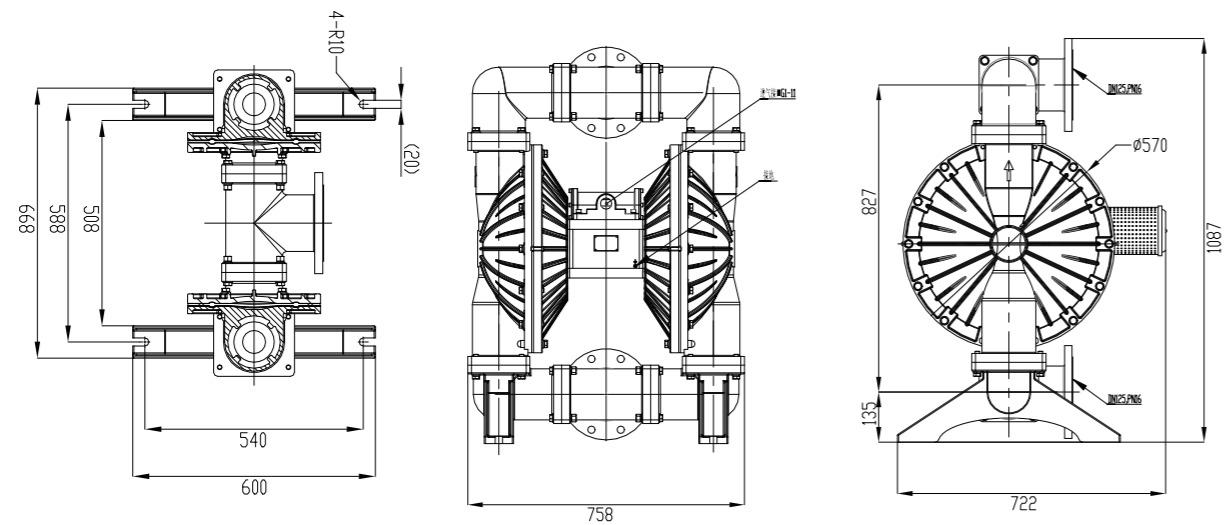

## BFD-25 铝合金/不锈钢/铸钢



### 性能曲线图

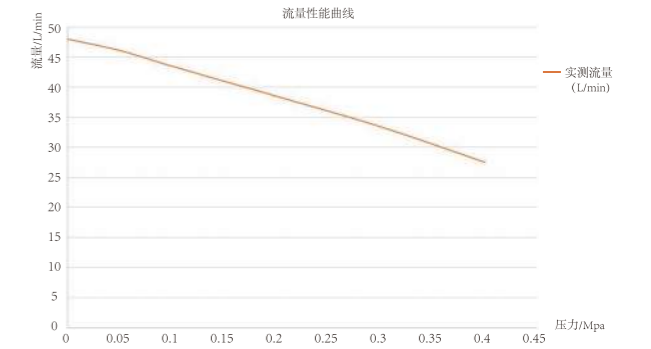

### 规格参数

最大工作流量 Max.Flow	12.7gpm ( 48Lpm )	最大输送固体颗粒 Max.Permitted Grain	1/8in.(3.2mm)
最大工作压力 Max.Working Pressure	0.4Mpa / 0.7Mpa	每往复流量 Every Reciprocating Flow	0.15gallon(0.57L)
流体进口尺寸 Fluid Inlet Size	1in.bsp ( f )	最大往复速度 Max.Reciprocating Speed	85cpm
流体出口尺寸 Fluid Outlet Size	1in.bsp ( f )	出口压力 Outlet Pressure	0.4Mpa / 0.7Mpa
最大虹吸高度(干抽或湿抽)		电机功率 Motor power	1.5kw / 2.2kw
Max.Suction height(dry suction or wet suction)	13ft.(4m )		

### 安装尺寸图

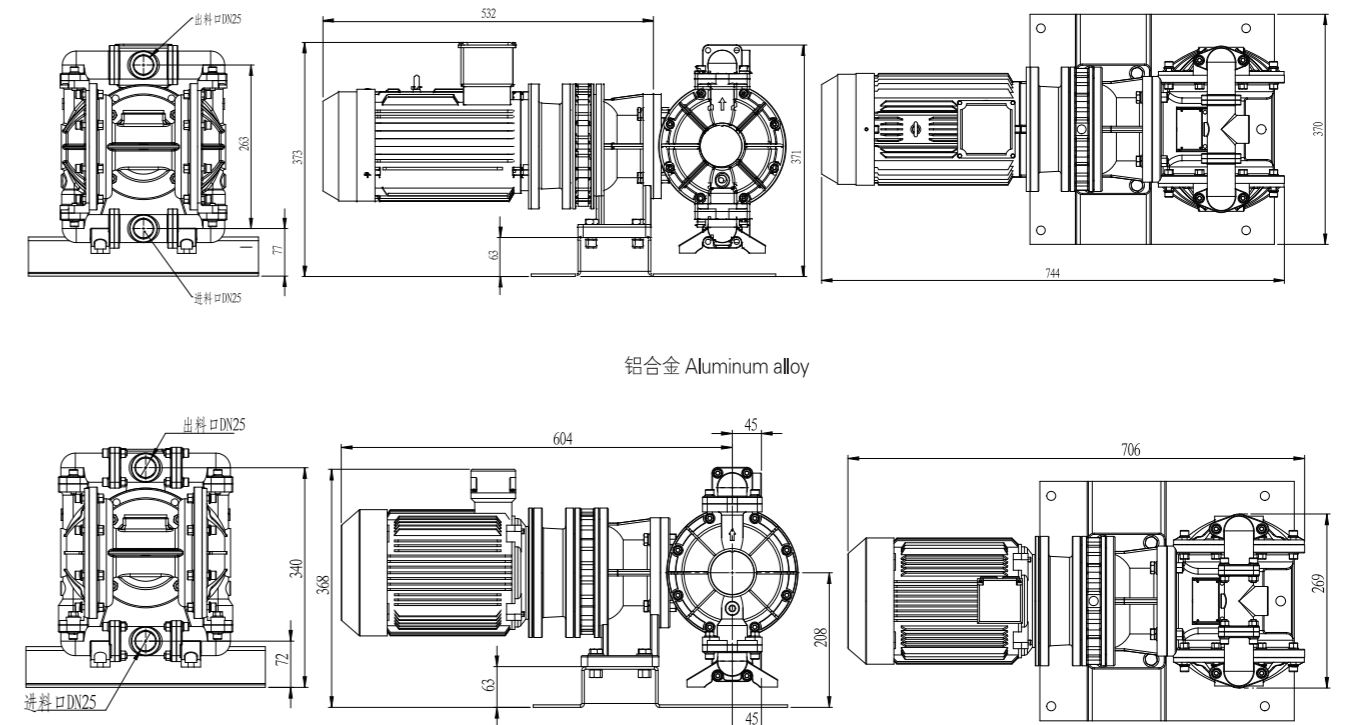

不锈钢/球铁 Stainless steel/Nodular cast iron

## BFD-25 塑料/氟塑料/衬氟



性能曲线图

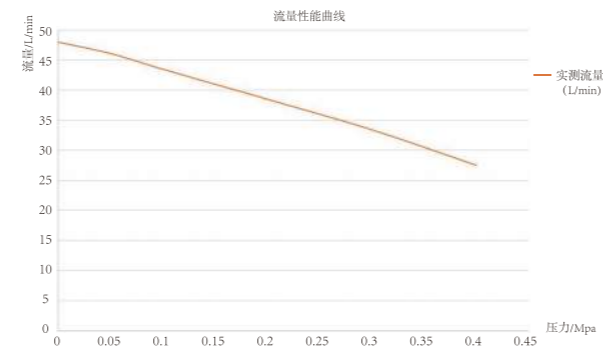

### 规格参数

最大工作流量 Max.Flow	12.7gpm ( 48lpm )	最大输送固体颗粒 Max.Permitted Grain	1/8in.(3.2mm)
最大工作压力 Max.Working Pressure	0.4Mpa / 0.7Mpa	每往复流量 Every Reciprocating Flow	0.15gallon(0.57L)
流体进口尺寸 Fluid Inlet Size	1in.bsp ( f )	最大往复速度 Max.Reciprocating Speed	85cpm
流体出口尺寸 Fluid Outlet Size	1in.bsp ( f )	出口压力 Outlet Pressure	0.4Mpa / 0.7Mpa
最大虹吸高度(干抽或湿抽)		电机功率 Motor power	1.5kw / 2.2kw
Max.Suction height(dry suction or wet suction)	13ft.(4m )		

### 安装尺寸图

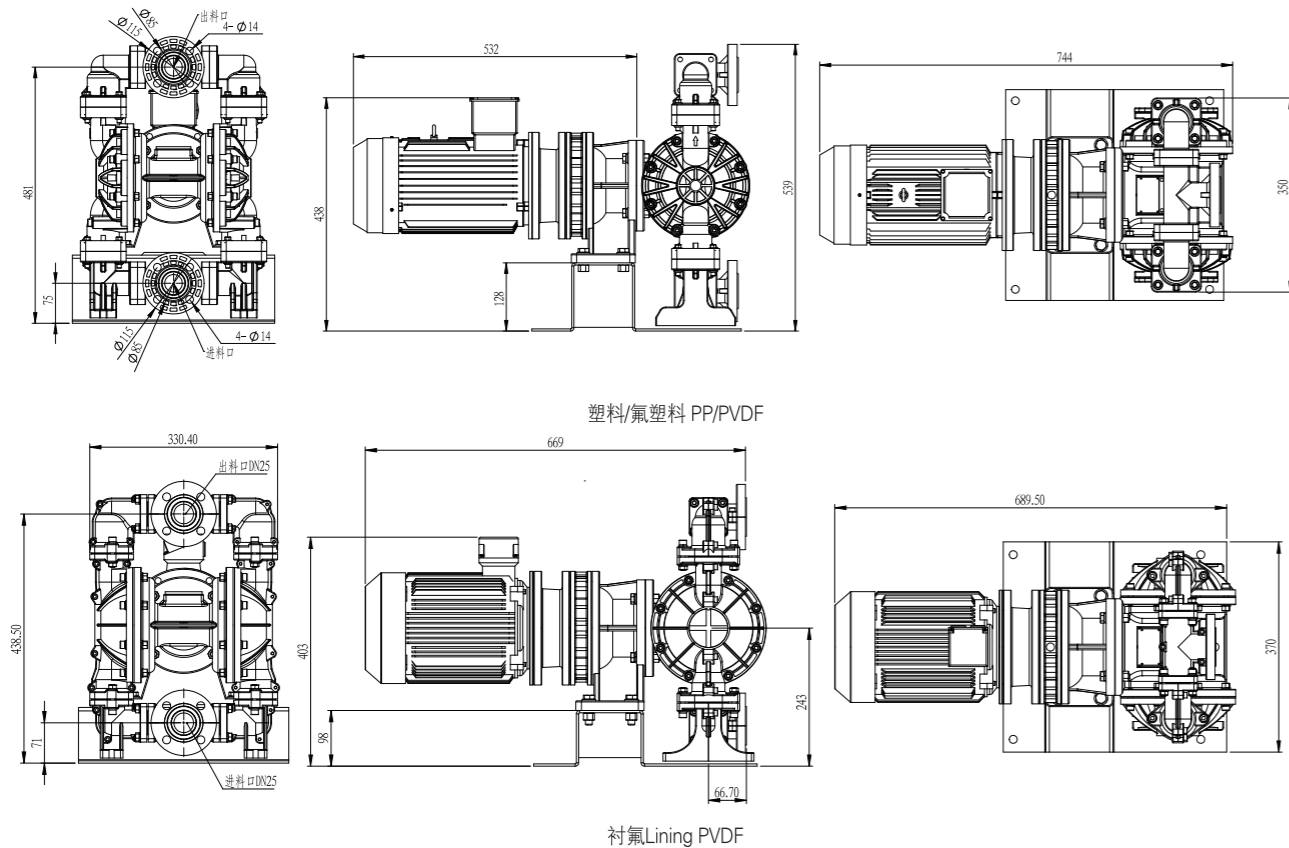

## BFD-40 铝合金/不锈钢/球铁



性能曲线图

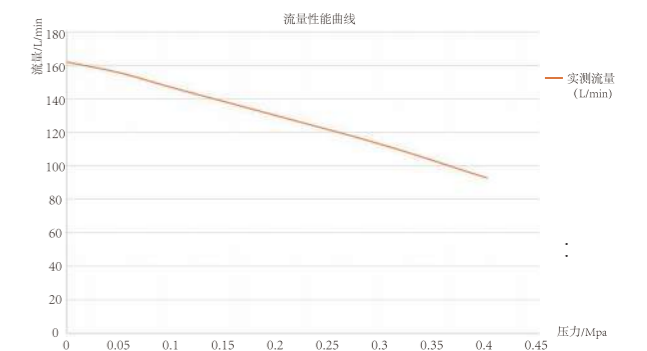

### 规格参数

最大工作流量 Max.Flow	42.8gpm ( 162lpm )	最大输送固体颗粒 Max.Permitted Grain	3/16in.(4.8mm)
最大工作压力 Max.Working Pressure	0.4Mpa / 0.7Mpa	每往复流量 Every Reciprocating Flow	0.5gallon(1.9L)
流体进口尺寸 Fluid Inlet Size	1-1/2in.bsp ( f )	最大往复速度 Max.Reciprocating Speed	85cpm
流体出口尺寸 Fluid Outlet Size	1-1/2in.bsp ( f )	出口压力 Outlet Pressure	0.4Mpa / 0.7Mpa
最大虹吸高度(干抽或湿抽)		电机功率 Motor power	2.2kw / 3kw
Max.Suction height(dry suction or wet suction)	16.4ft.(5m )		

### 安装尺寸图

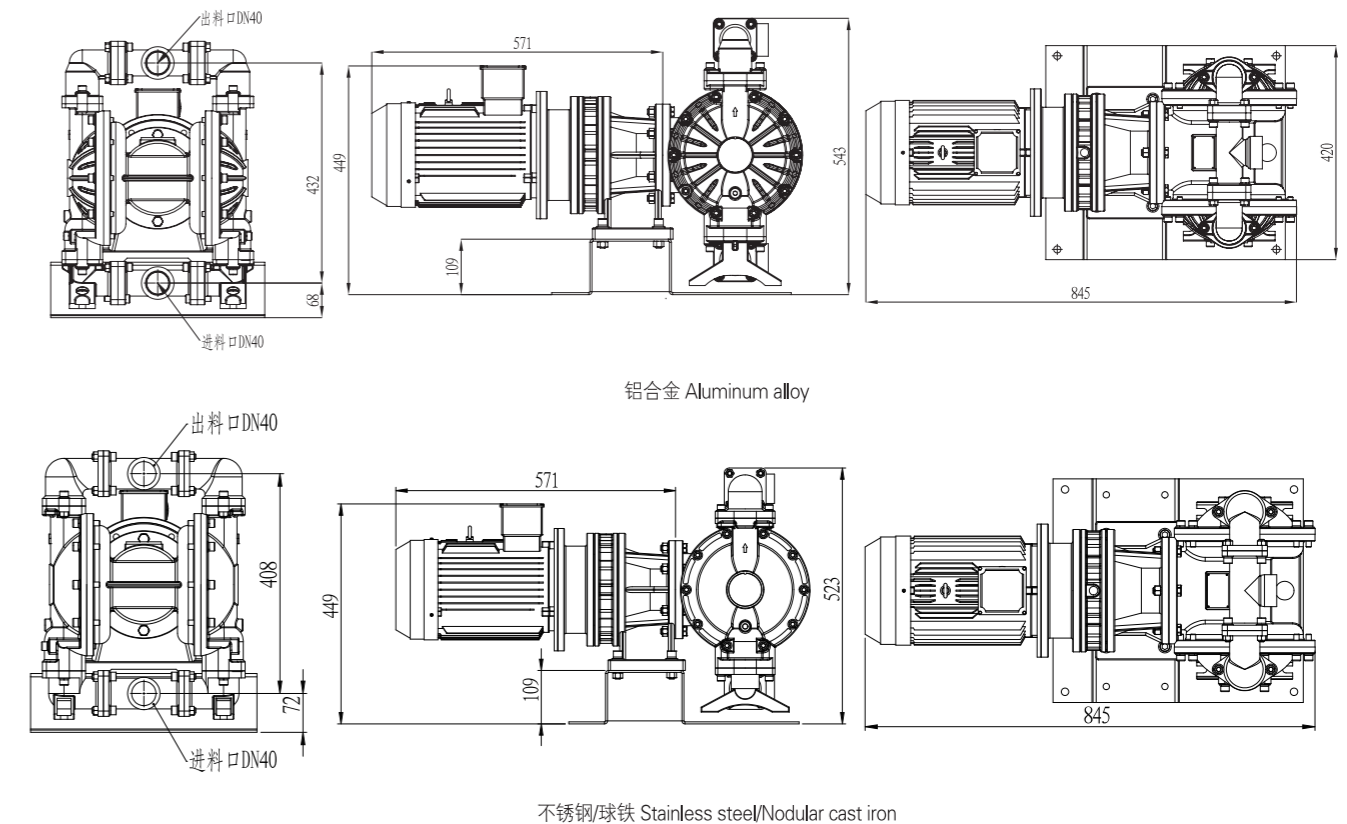

## BFD-40 塑料/氟塑料/衬氟



### 性能曲线图

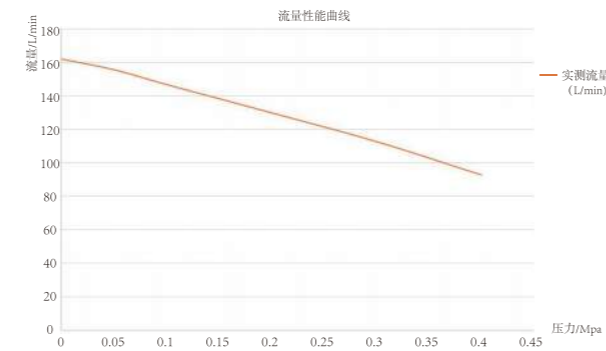

### 规格参数

最大工作流量 Max.Flow	42.8gpm ( 162lpm )	最大输送固体颗粒 Max.Permitted Grain	3/16in.(4.8mm)
最大工作压力 Max.Working Pressure	0.4Mpa / 0.7Mpa	每往复流量 Every Reciprocating Flow	0.5gallon(1.9L)
流体进口尺寸 Fluid Inlet Size	1-1/2in.bsp ( f )	最大往复速度 Max.Reciprocating Speed	85cpm
流体出口尺寸 Fluid Outlet Size	1-1/2in.bsp ( f )	出口压力 Outlet Pressure	0.4Mpa / 0.7Mpa
最大虹吸高度(干抽或湿抽)		电机功率 Motor power	2.2kw / 3kw
Max.Suction height(dry suction or wet suction)	16.4ft.(5m )		

### 安装尺寸图

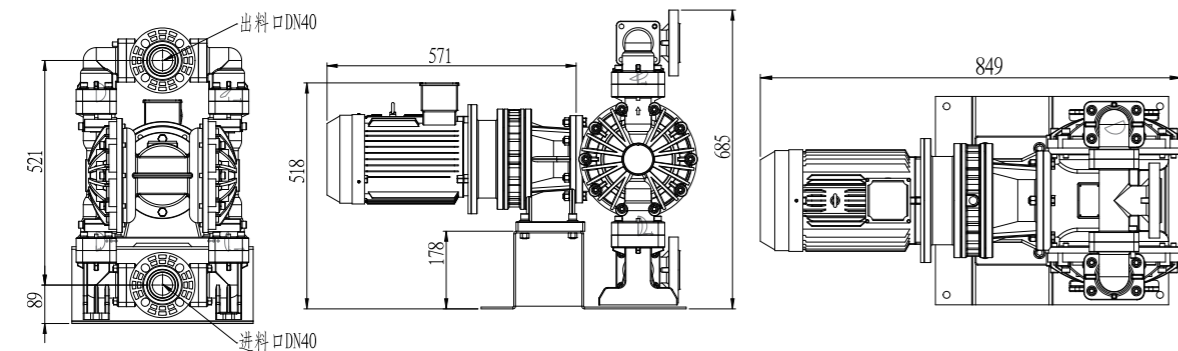

塑料/氟塑料 PP/PVDF

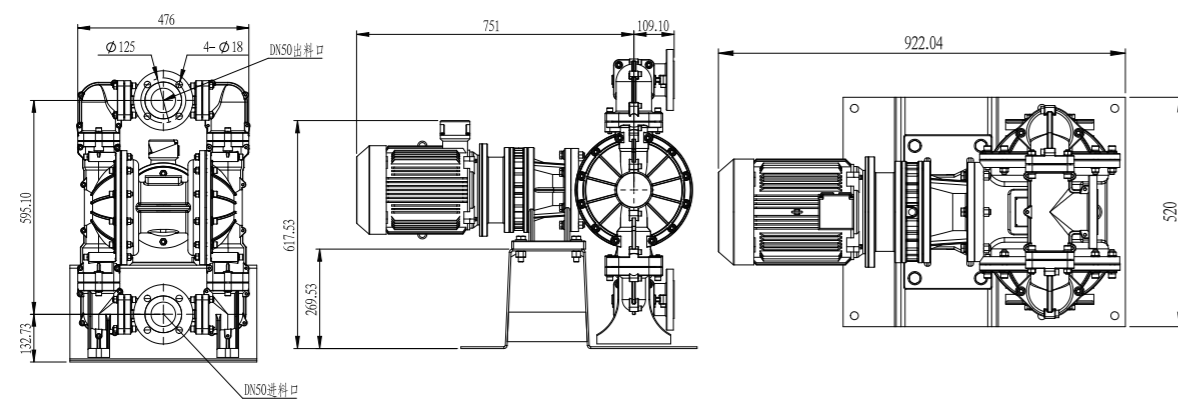

衬氟Lining PVDF

## BFD-50 铝合金/不锈钢/球铁



### 性能曲线图



### 规格参数

最大工作流量 Max.Flow	64.7gpm ( 245lpm )	最大输送固体颗粒 Max.Permitted Grain	1/4in.(6.4mm)
最大工作压力 Max.Working Pressure	0.4Mpa / 0.7Mpa	每往复流量 Every Reciprocating Flow	1.03gallon(3.9L)
流体进口尺寸 Fluid Inlet Size	2in.bsp ( f )	最大往复速度 Max.Reciprocating Speed	63cpm
流体出口尺寸 Fluid Outlet Size	2in.bsp ( f )	出口压力 Outlet Pressure	0.4Mpa / 0.7Mpa
最大虹吸高度(干抽或湿抽)		电机功率 Motor power	3kw / 4kw
Max.Suction height(dry suction or wet suction)	16.4ft.(5m )		

### 安装尺寸图

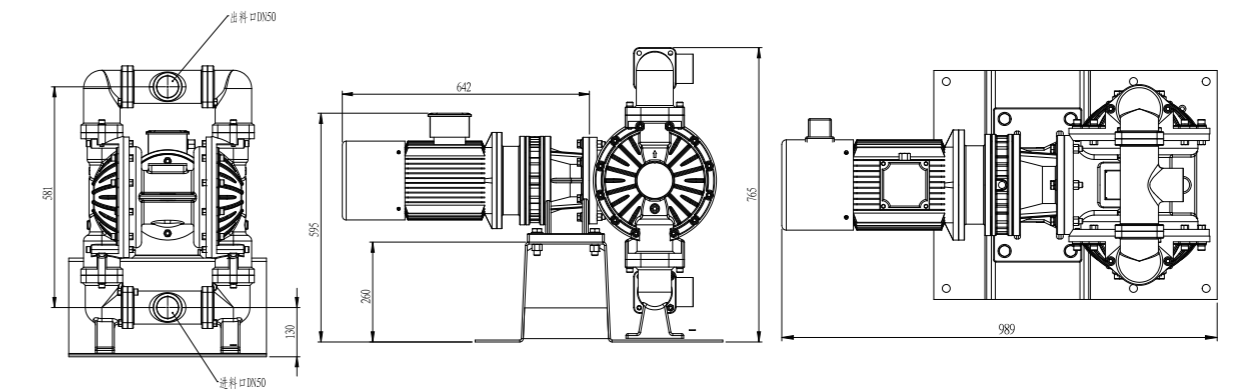

铝合金 Aluminum alloy

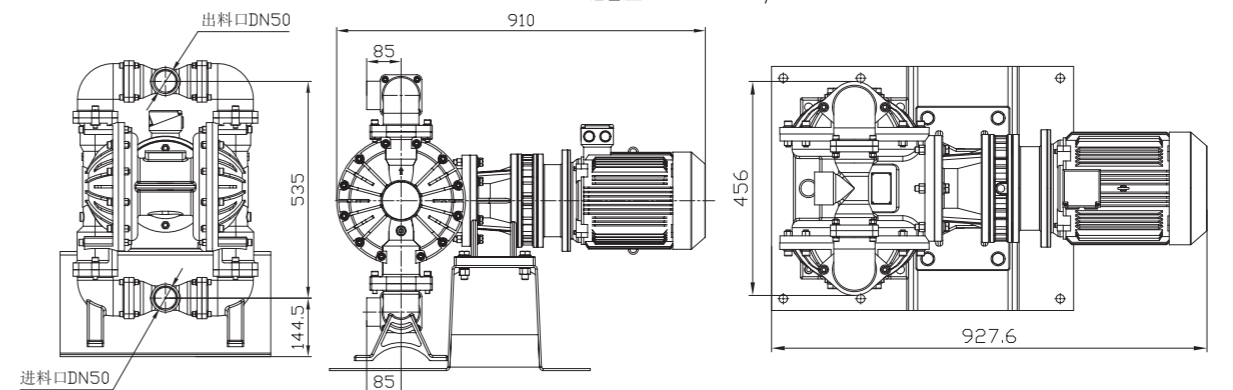

不锈钢/球铁 Stainless steel/Nodular cast iron

## BFD-50 塑料/氟塑料/衬氟



### 性能曲线图

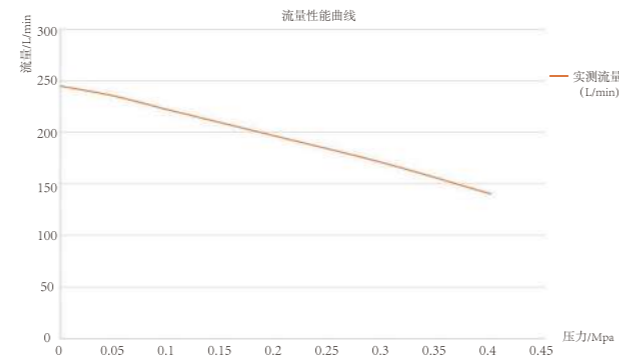

### 规格参数

最大工作流量 Max.Flow	64.7gpm ( 245lpm )	最大输送固体颗粒 Max.Permitted Grain	1/4in.(6.4mm)
最大工作压力 Max.Working Pressure	0.4Mpa / 0.7Mpa	每往复流量 Every Reciprocating Flow	1.03gallon(3.9L)
流体进口尺寸 Fluid Inlet Size	2in.bsp ( f )	最大往复速度 Max.Reciprocating Speed	63cpm
流体出口尺寸 Fluid Outlet Size	2in.bsp ( f )	出口压力 Outlet Pressure	0.4Mpa / 0.7Mpa
最大虹吸高度(干抽或湿抽)		电机功率 Motor power	3kw / 4kw
Max.Suction height(dry suction or wet suction)	16.4ft.(5m )		

### 安装尺寸图

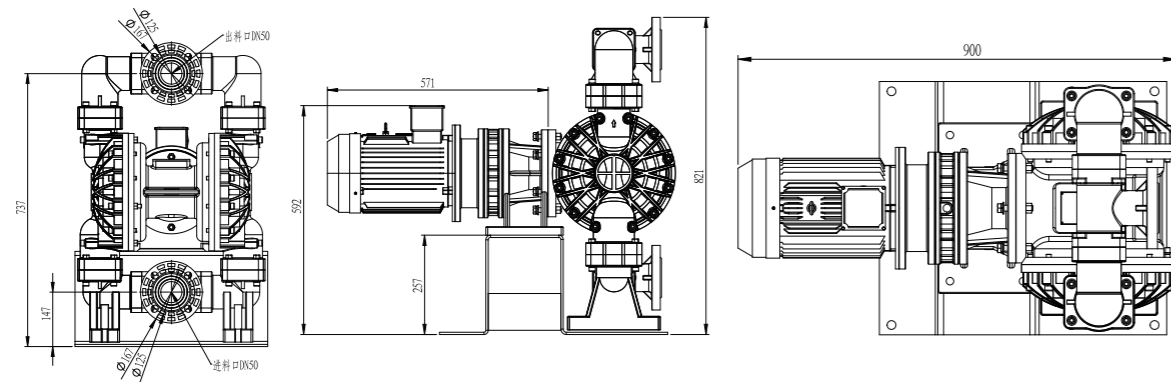

塑料/氟塑料 PP/PVDF

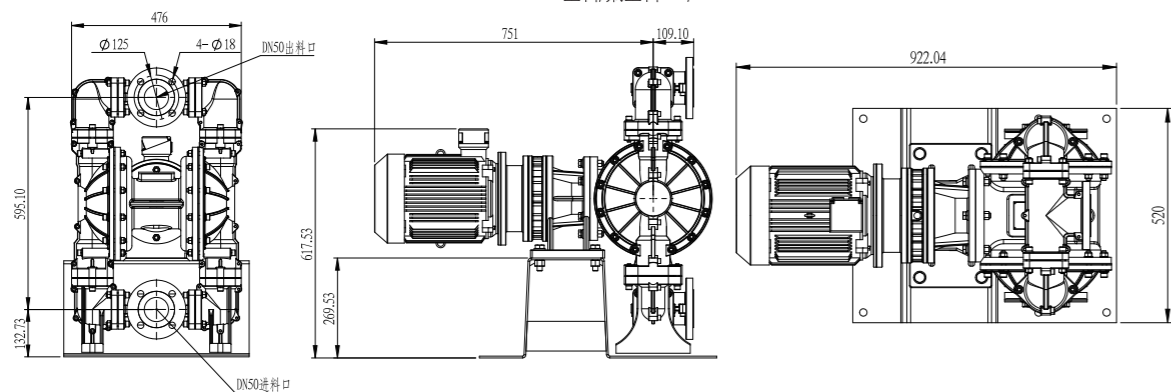

衬氟Lining PVDF

## BFD-80 铝合金/不锈钢/球铁



### 性能曲线图

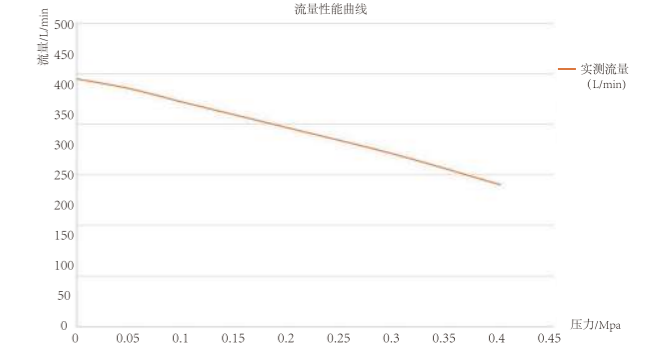

### 规格参数

最大工作流量 Max.Flow	126.8gpm ( 480Lpm )	最大输送固体颗粒 Max.Permitted Grain	3/8in.(9.4mm)
最大工作压力 Max.Working Pressure	0.4Mpa / 0.7Mpa	每往复流量 Every Reciprocating Flow	2.0gallon(7.6L)
流体进口尺寸 Fluid Inlet Size	3in.bsp ( f )	最大往复速度 Max.Reciprocating Speed	63cpm
流体出口尺寸 Fluid Outlet Size	3in.bsp ( f )	出口压力 Outlet Pressure	0.4Mpa / 0.7Mpa
最大虹吸高度(干抽或湿抽)		电机功率 Motor power	4kw / 5.5kw
Max.Suction height(dry suction or wet suction)	20ft.(6m )		

### 安装尺寸图

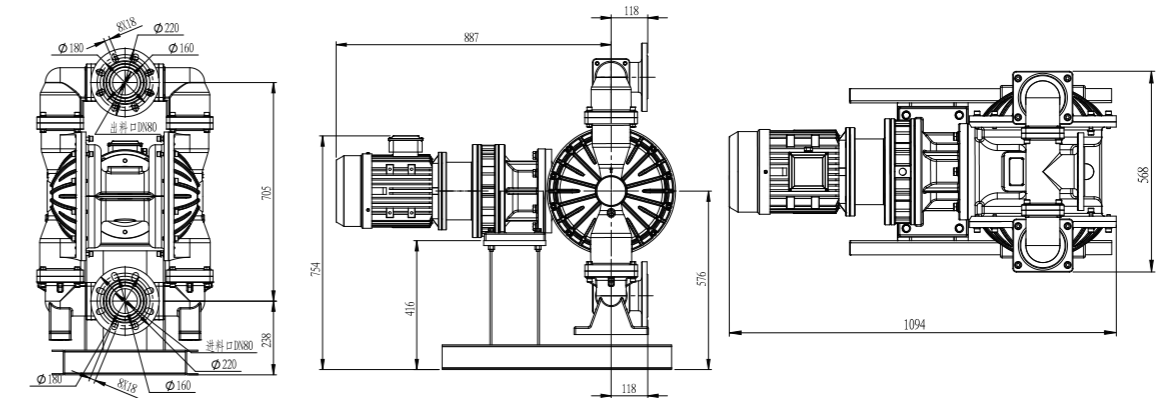

铝合金 Aluminum alloy

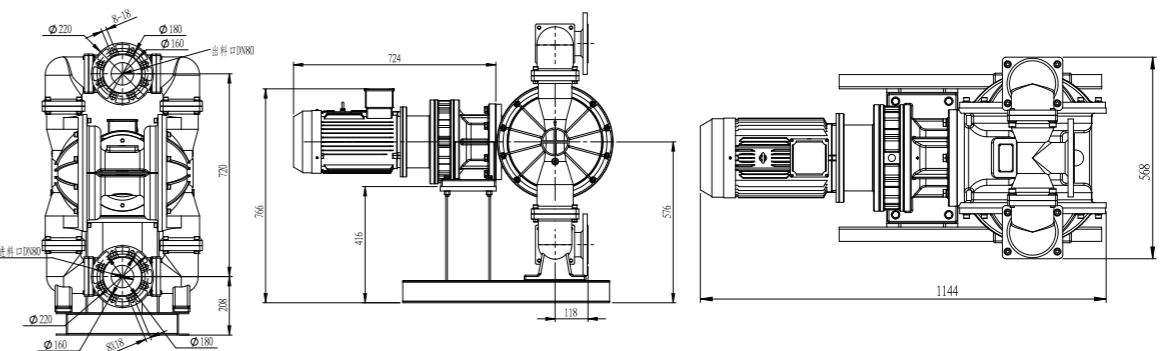

不锈钢/球铁 Stainless steel/Nodular cast iron

## BFD-80 塑料/氟塑料/衬氟



### 性能曲线图

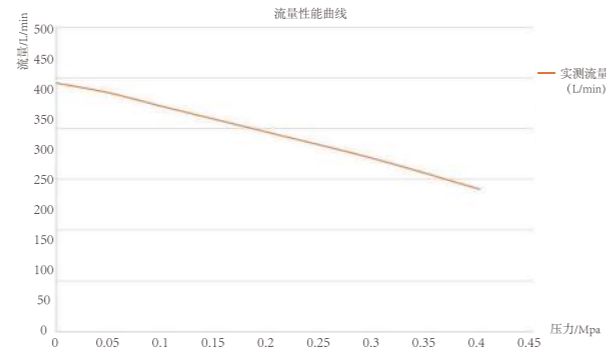

### 规格参数

最大工作流量 Max.Flow	126.8gpm ( 480Lpm )	最大输送固体颗粒 Max.Permitted Grain	3/8in.(9.4mm)
最大工作压力 Max.Working Pressure	0.4Mpa / 0.7Mpa	每往复流量 Every Reciprocating Flow	2.0gallon(7.6L)
流体进口尺寸 Fluid Inlet Size	3in. bsp ( f )	最大往复速度 Max.Reciprocating Speed	63cpm
流体出口尺寸 Fluid Outlet Size	3in. bsp ( f )	出口压力 Outlet Pressure	0.4Mpa / 0.7Mpa
最大虹吸高度(干抽或湿抽)		电机功率 Motor power	4kw / 5.5kw
Max.Suction height(dry suction or wet suction)	20ft.(6m)		

### 安装尺寸图

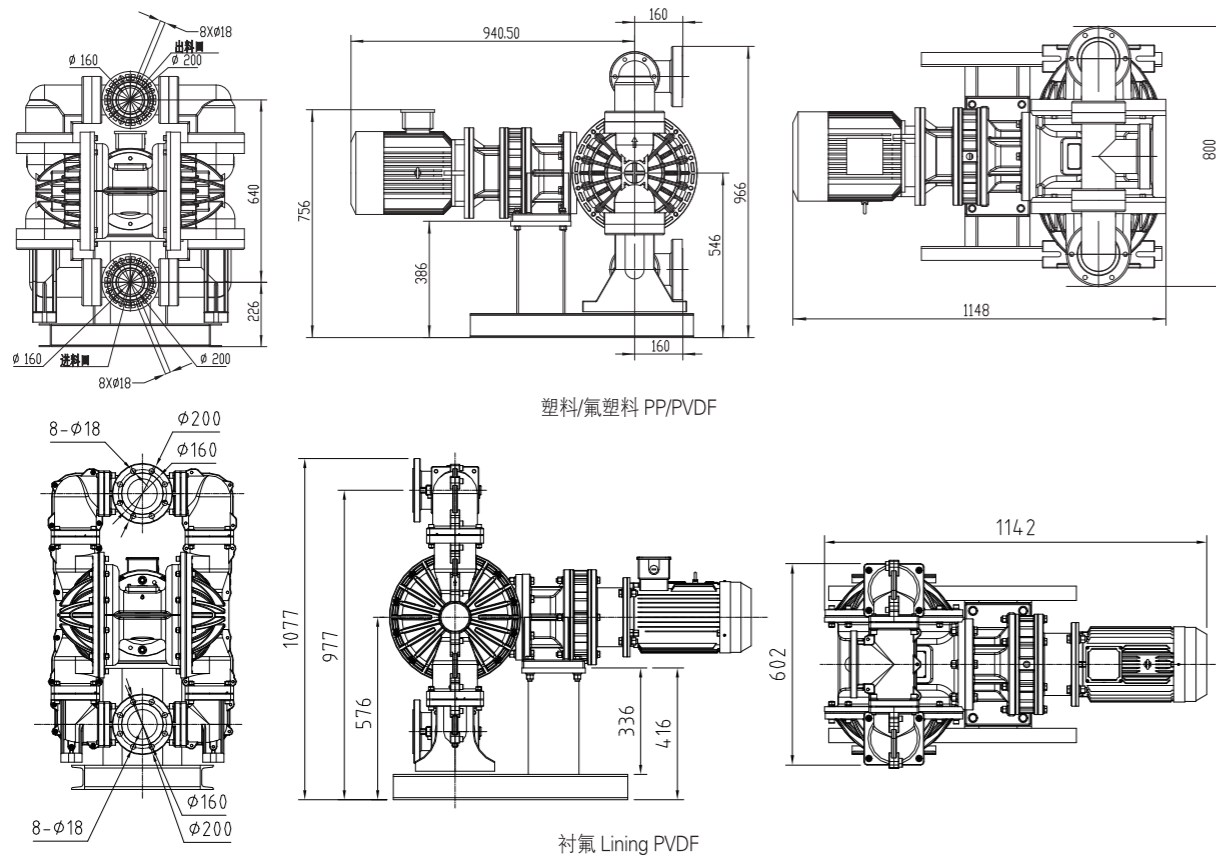

## BFQJ-40 不锈钢/不锈钢316



### 性能曲线图

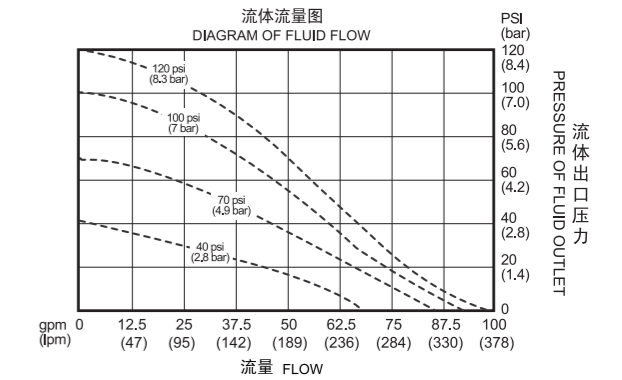

### 规格参数

最大工作流量 Max. Flow	100 gpm (378.5 lpm)	最大虹吸高度 (干抽或湿抽)	18 ft. (5.48 m)
最大工作压力 Max. Working Pressure	120 psi (0.84 Mpa, 8.4 bar)	Max.Suction Height (dry suction or wet suction)	18 ft. (5.48 m)
流体进口尺寸 Fluid Inlet Size	1-1/2 in. bsp (f)	最大输送固体颗粒 Max. Permitted Grain	3/16 in. (4.8 mm)
流体出口尺寸 Fluid Outlet Size	1-1/2 in. bsp (f)	每往复流量 Every Reciprocating Flow	0.5 gal. (1.9 L)
空气进口尺寸 Air Inlet Size	1/2 in. bsp (f)	最大往复速度 Max. Reciprocating Speed	200 cpm

### 安装尺寸图

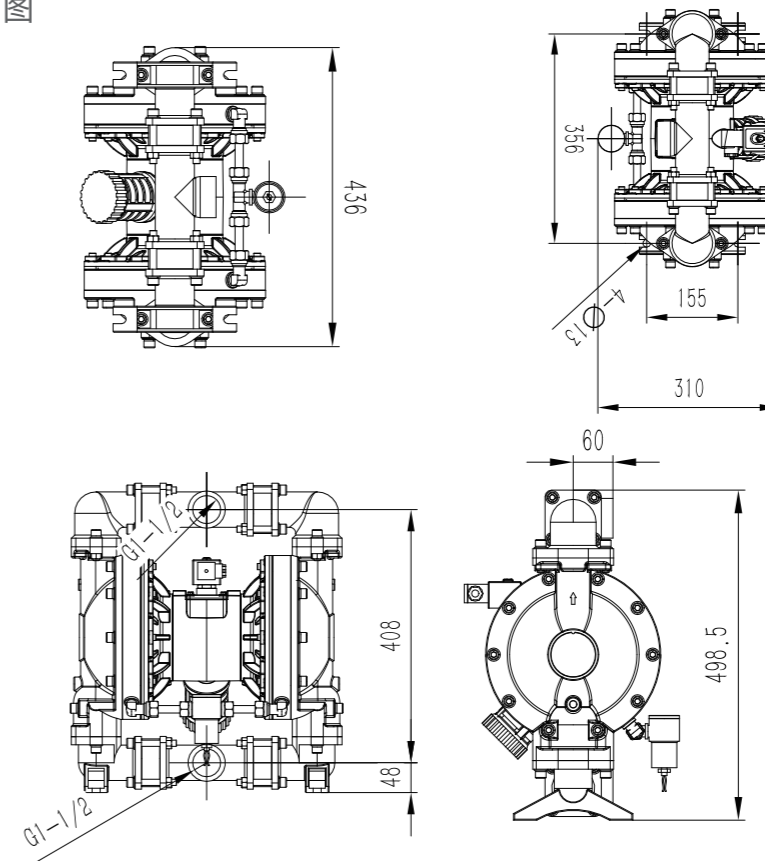

## BFQJ-50 不锈钢/不锈钢316

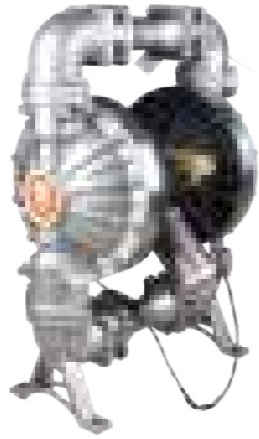

性能曲线图

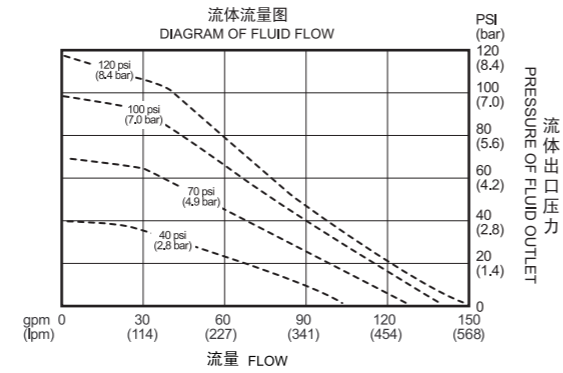

### 规格参数

最大工作流量 Max. Flow	150 gpm (568 lpm)	最大虹吸高度 (干抽或湿抽) Max.Suction Height (dry suction or wet suction)	18 ft. (5.48 m)
最大工作压力 Max. Working Pressure	120 psi (0.84 Mpa, 8.4 bar)	最大输送固体颗粒 Max. Permitted Grain	45 scfm
流体进口尺寸 Fluid Inlet Size	2 in. bsp (f)	每往复流量 Every Reciprocating Flow	1.03 gal. (3.90 L)
流体出口尺寸 Fluid Outlet Size	2 in. bsp (f)	最大往复速度 Max. Reciprocating Speed	145 cpm
空气进口尺寸 Air Inlet Size	1/2 in. bsp (f)		

### 安装尺寸图

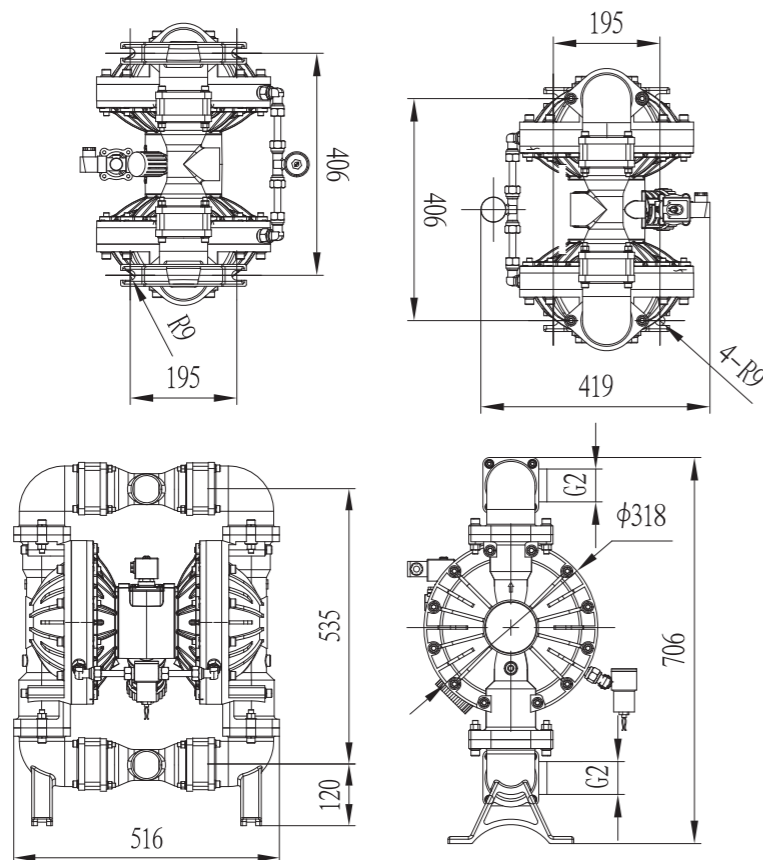

## BFQJ-80 不锈钢/不锈钢316



性能曲线图

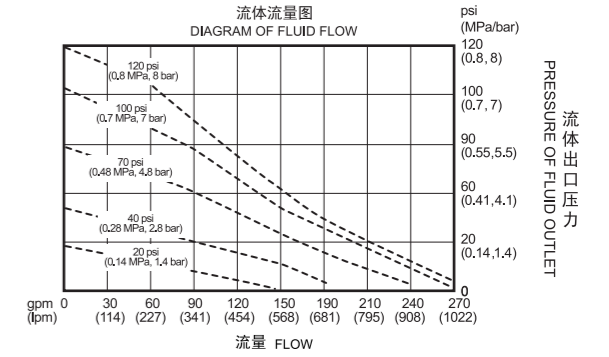

### 规格参数

最大工作流量 Max. Flow	275 gpm (1041 lpm)	最大虹吸高度 (干抽或湿抽) Max.Suction Height (dry suction or wet suction)	25 ft. (7.6 m)
最大工作压力 Max. Working Pressure	120 psi (0.84 Mpa, 8.4 bar)	最大输送固体颗粒 Max. Permitted Grain	82.6 scfm
流体进口尺寸 Fluid Inlet Size	3 in. bsp (f)	每往复流量 Every Reciprocating Flow	2.0 gal. (7.6 L)
流体出口尺寸 Fluid Outlet Size	3 in. bsp (f)	最大往复速度 Max. Reciprocating Speed	135 cpm
空气进口尺寸 Air Inlet Size	3/4 in. bsp (f)		

### 安装尺寸图

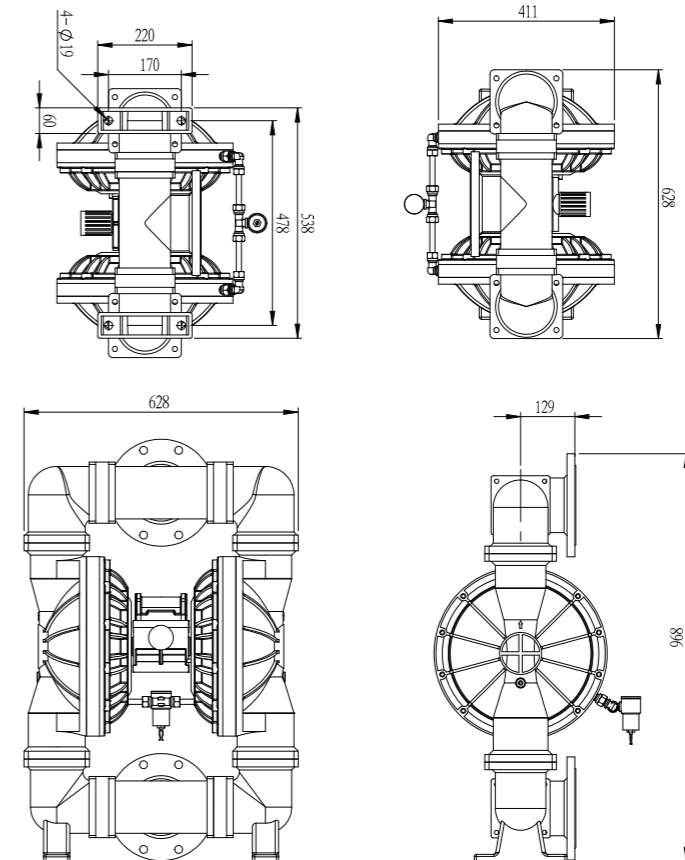

# 03

**BQG**

小灵通矿用  
气动隔膜泵



## BQG100/0.2 铝合金



### 性能曲线图

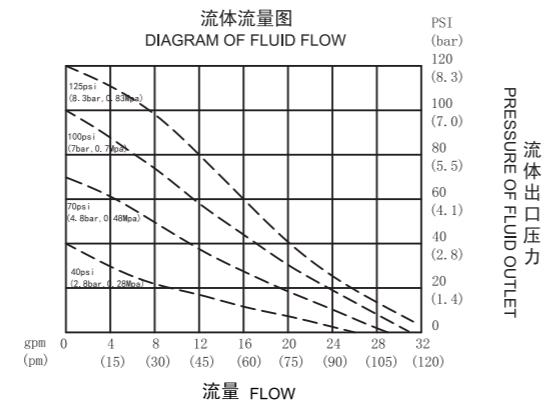

### 规格参数

额定流量 Rated flow	100 L/min	最大颗粒物直径 Max. Passing particle diameter	3.2 mm
额定排出压力 Outlet pressure	0.2 Mpa	管口螺纹规格	
工作气压 Rated air consumption	0.4-0.7 Mpa	Pipe opening thread specification	G1-11
吸程 Suction lift	4 m	进气口规格 Air inlet Specification	G1/2-14
额定供气压力 Rated gas supply Pressure	0.5 Mpa	耗气量 Gas consumption	≤1000 L/min

### 安装尺寸图

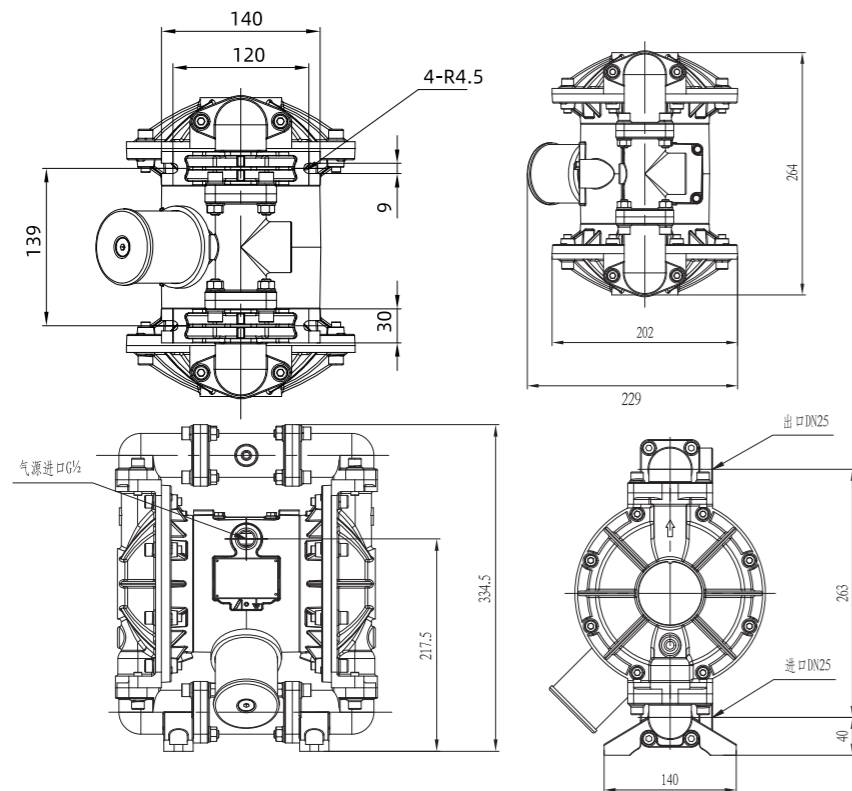

## BQG200/0.2 铝合金



### 性能曲线图

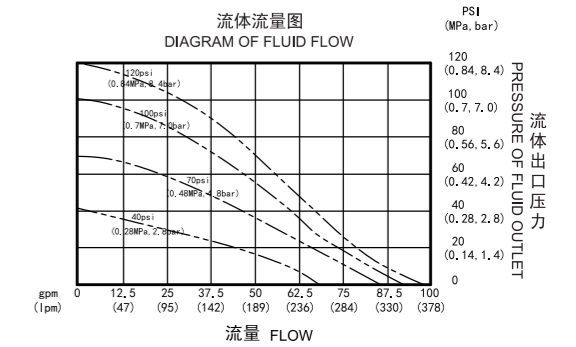

### 规格参数

额定流量 Rated flow	200 L/min	最大颗粒物直径 Max. Passing particle diameter	4.8 mm
额定排出压力 Outlet pressure	0.2 Mpa	管口螺纹规格	
工作气压 Rated air consumption	0.4-0.7 Mpa	Pipe opening thread specification	G1%-11
吸程 Suction lift	5 m	进气口规格 Air inlet Specification	G1/2-14
额定供气压力 Rated gas supply Pressure	0.5 Mpa	耗气量 Gas consumption	≤1400 L/min

### 安装尺寸图

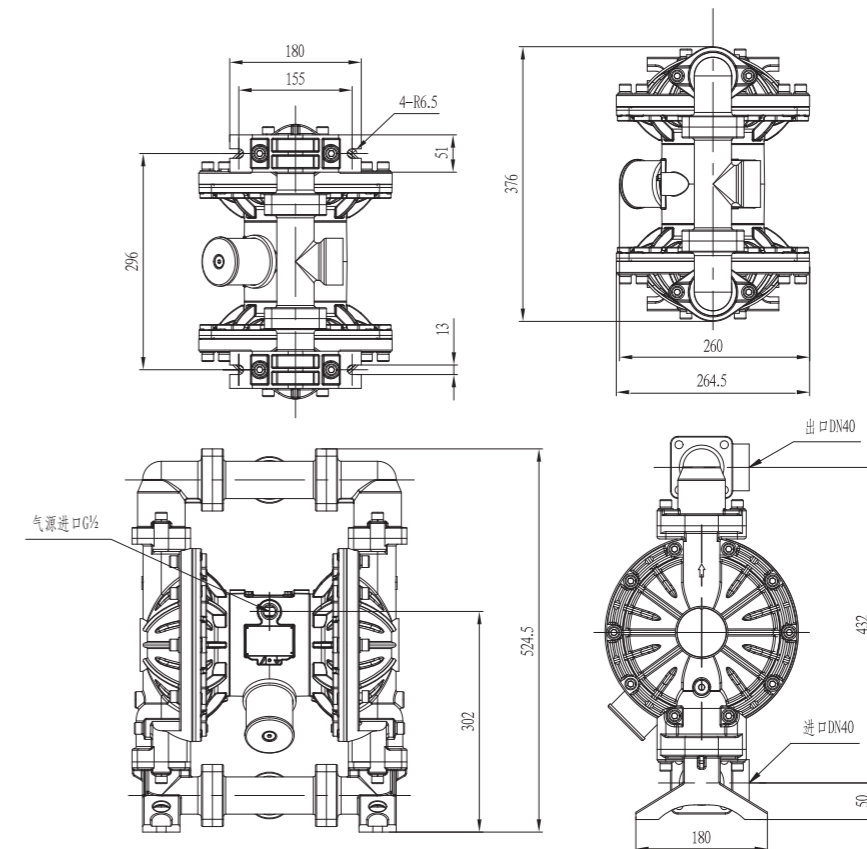

## BQG350/0.2 铝合金



### 性能曲线图

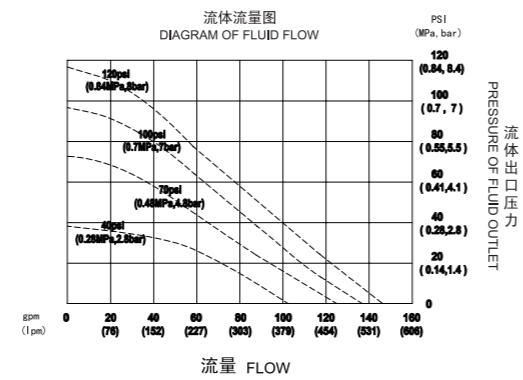

### 规格参数

额定流量 Rated flow	350 L/min	最大颗粒物直径 Max. Passing particle diameter	6.4 mm
额定排出压力 Outlet pressure	0.2 Mpa	管口螺纹规格	
工作气压 Rated air consumption	0.4-0.7 Mpa	Pipe opening thread specification	G2-11
吸程 Suction lift	4 m	进气口规格 Air inlet Specification	G1/2-14
额定供气压力 Rated gas supply Pressure	0.5 Mpa	耗气量 Gas consumption	≤1950 L/min

### 安装尺寸图

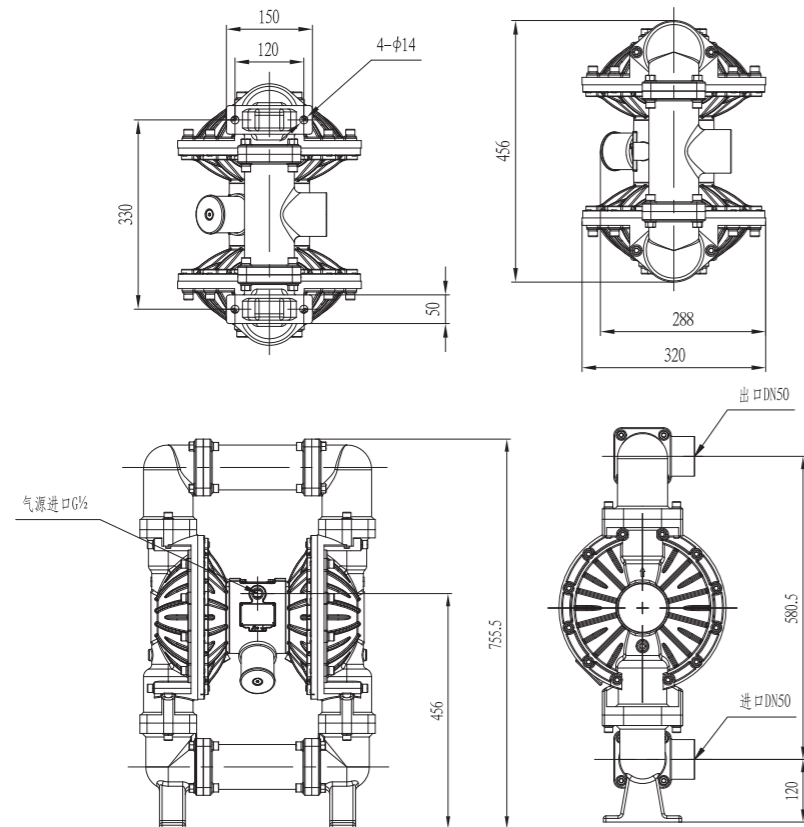

## BQG450/0.2 铝合金



### 性能曲线图

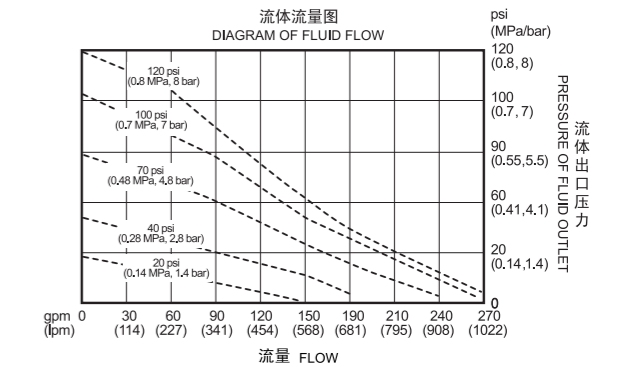

### 规格参数

额定流量 Rated flow	450 L/min	最大颗粒物直径 Max. Passing particle diameter	9.4 mm
额定排出压力 Outlet pressure	0.2 Mpa	管口螺纹规格	
工作气压 Rated air consumption	0.4-0.7 Mpa	Pipe opening thread specification	DN80 法兰
吸程 Suction lift	5 m	进气口规格 Air inlet Specification	G3/4-14
额定供气压力 Rated gas supply Pressure	0.5 Mpa	耗气量 Gas consumption	≤2400 L/min

### 安装尺寸图

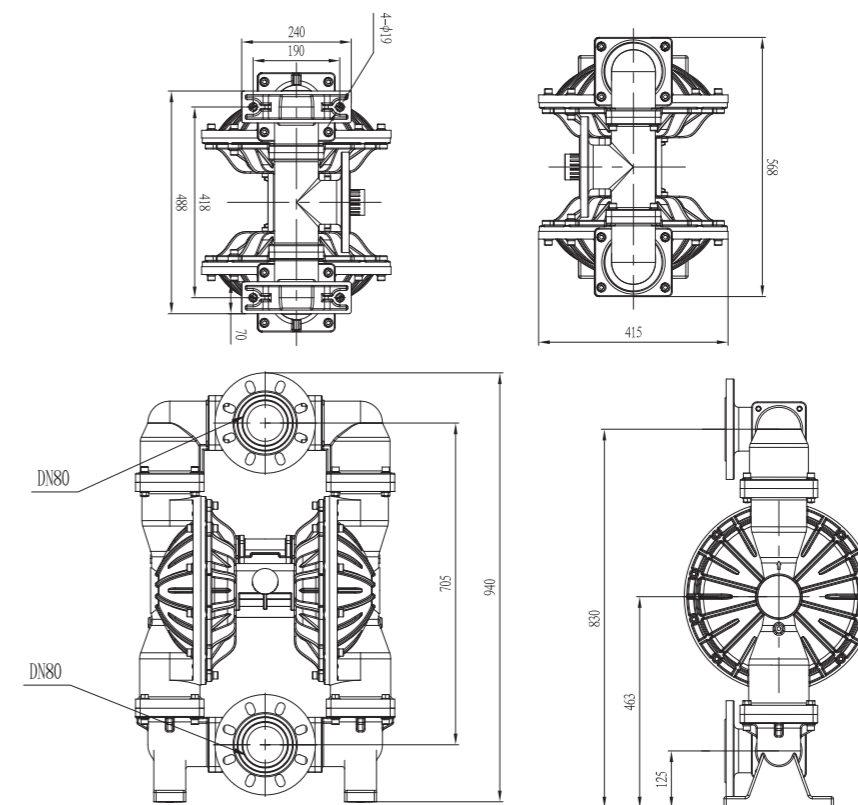

04

A&O

砂磨机专用泵



## RA-25L 铝合金

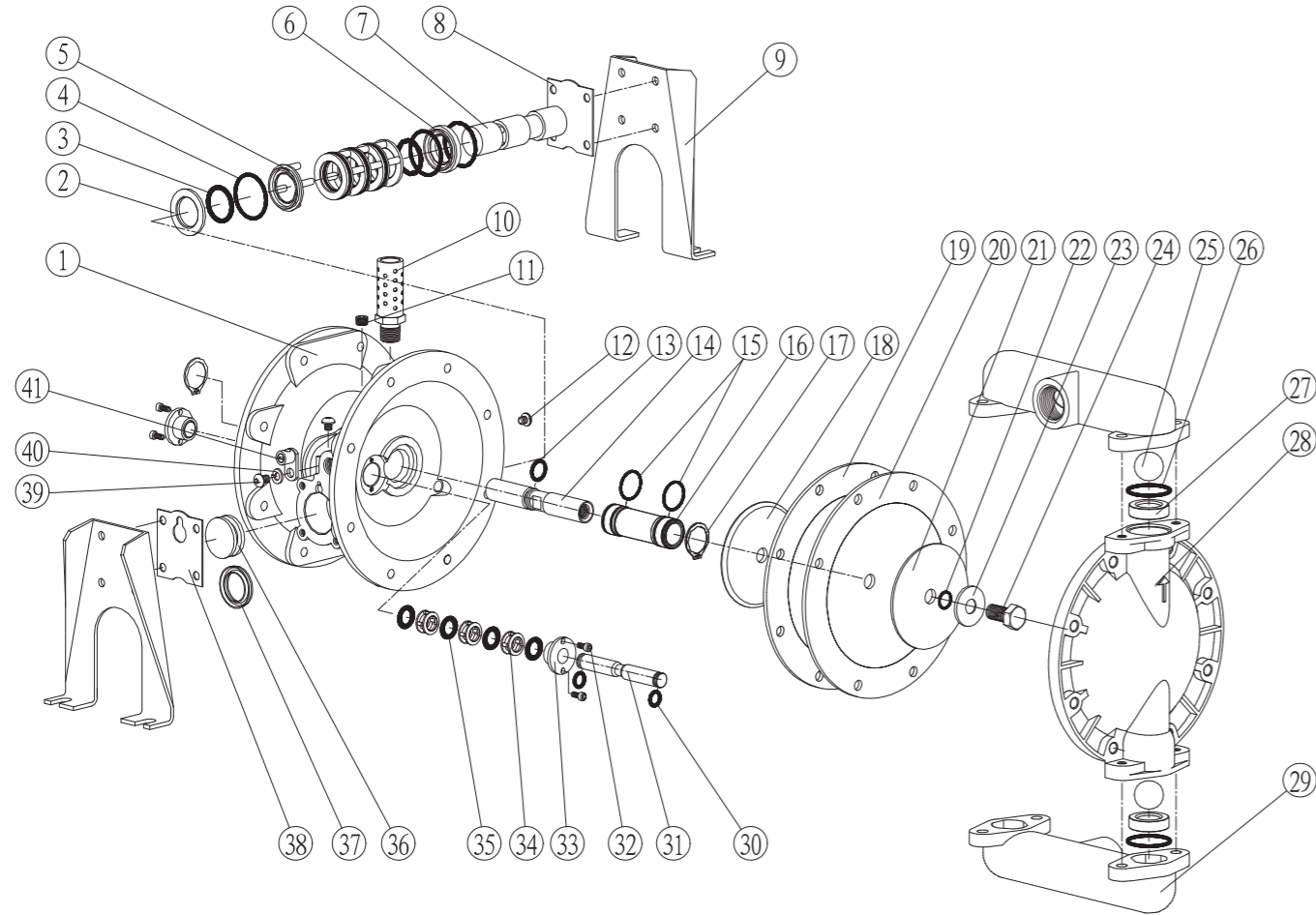

RA-25L零部件明细表

序号	名称	序号	名称	序号	名称	序号	名称
01	气阀室	02	夹片	03	隔圈小O型圈	04	隔圈大O型圈
05	大花篮	06	顶片	07	活塞杆	08	后盖板垫
09	泵体支架	10	消声器	11	堵头	12	螺钉
13	连杆密封圈	14	连杆轴	15	轴套O型圈	16	连杆轴套
17	卡环	18	内夹板	19	山道隔膜	20	特氟龙隔膜
21	外夹板	22	夹板密封圈	23	夹板螺栓垫片	24	夹板螺栓
25	球阀	26	球座	27	球座密封圈	28	立柱
29	进出料口	30	助动杆挡圈	31	助动杆	32	铜套螺钉
33	助动杆铜套	34	小花篮	35	助动杆O型圈	36	活塞
37	V型圈	38	前盖垫板	39	接地端子螺钉	40	接地端子弹垫
41	接地端子						



### 性能曲线图

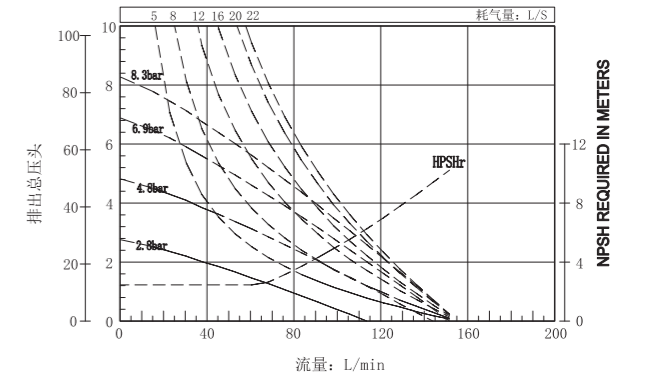

最大进气压力 Max. Intake Pressure 120psi (8.3 bar)  
 最大虹吸高度 Max. Suction Height 8 psi (0.55 bar)  
 最大工作压力 Max. Working Pressure 120psi (8.3bar)

最大流量 Max. Flow 35gpm (133lpm)  
 最大颗粒尺寸 Max. Particle Size 1/8" dia. (3.2 mm)  
 最大耗气量 Max. Permitted Grain 45scfm (1.3m<sup>3</sup>/min)

两种膜片可供选择：特氟龙隔膜 / 三道隔膜 Two diaphragms are available: Teflon diaphragms/Three diaphragms

### 安装尺寸图

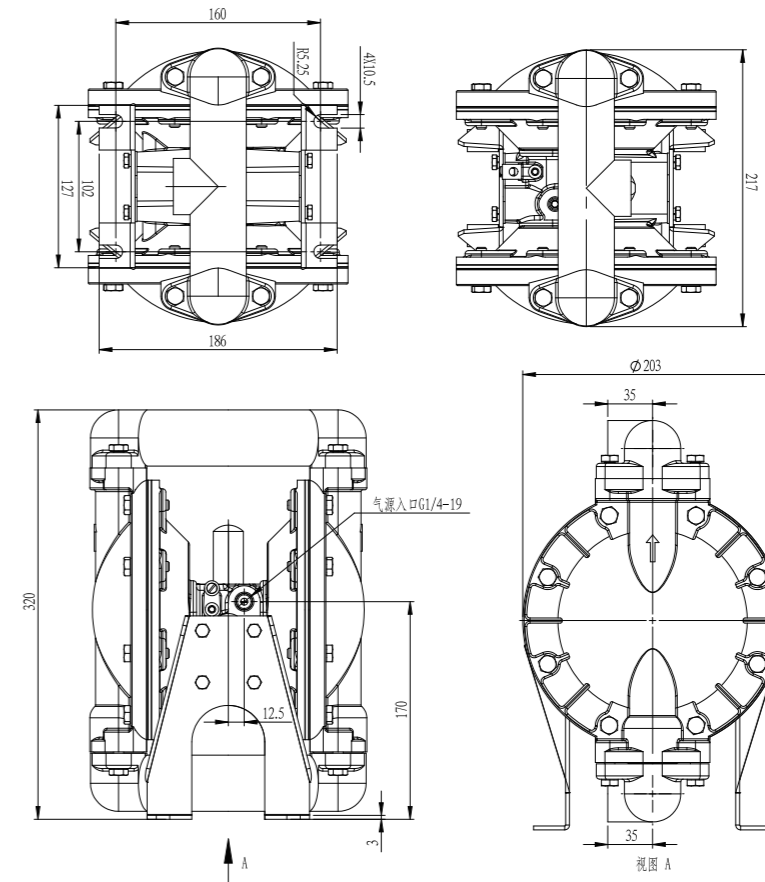

# 05

**GDC**  
船用泵



## GDC-40 不锈钢304



### 性能曲线图

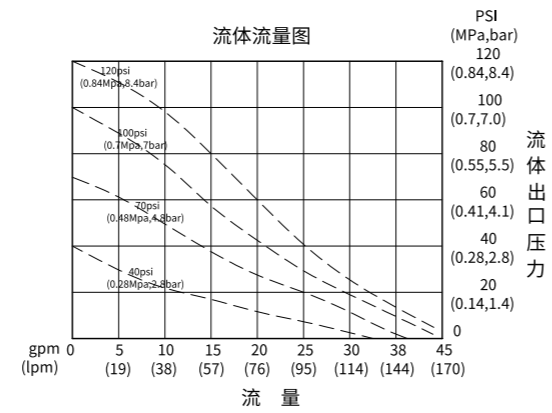

### 规格参数

最大流量 Max. Flow	150 L/min	最大空气消耗量 Max. air consumption	90 m <sup>3</sup> /h
最大排出压力 Max. discharge pressure	0.7 Mpa	吸程 Suction lift	5 m
真空度 Vacuum degree	0.05 Mpa	最大允许颗粒直径 Max. Passing particle diameter	3.2 mm

### 安装尺寸图

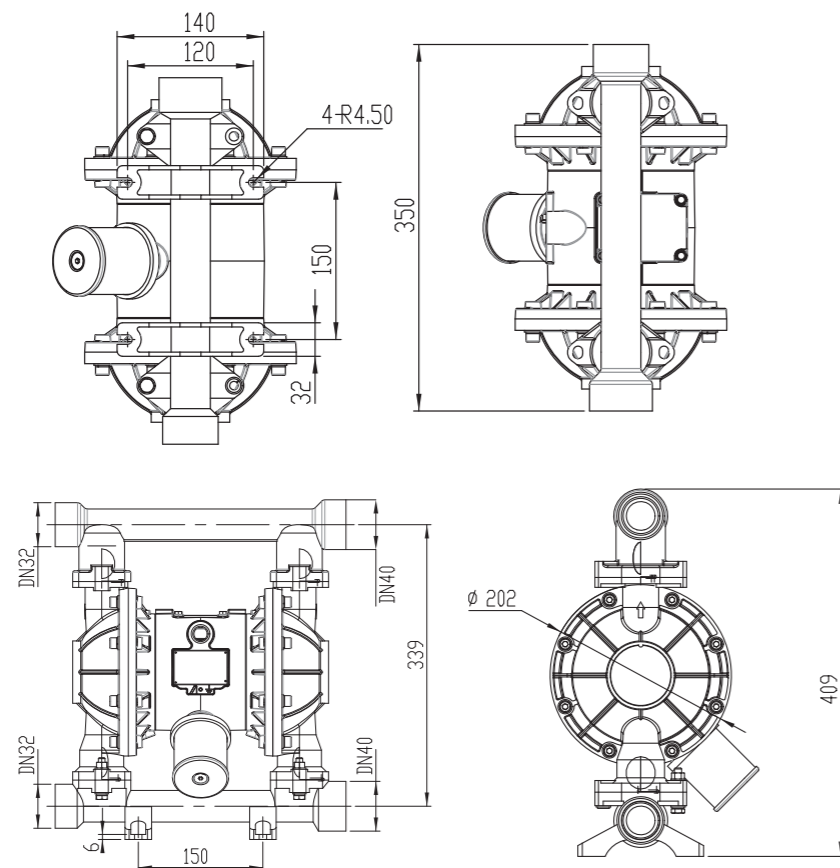

## GDC-50 不锈钢304



### 性能曲线图

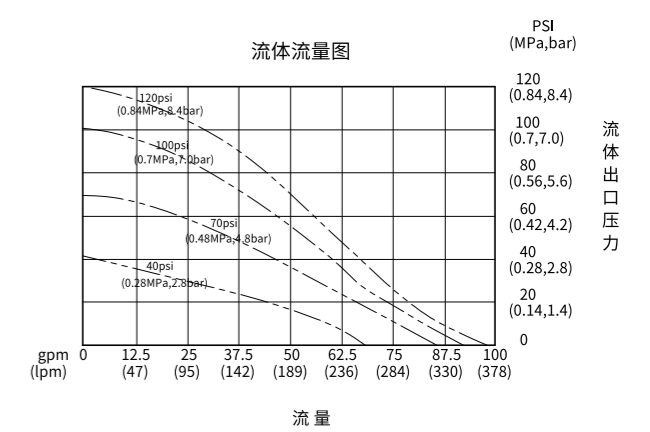

### 规格参数

最大流量 Max. Flow	250 L/min	最大空气消耗量 Max. air consumption	180 m <sup>3</sup> /h
最大排出压力 Max. discharge pressure	0.7 Mpa	吸程 Suction lift	5 m
真空度 Vacuum degree	0.05 Mpa	最大允许颗粒直径 Max. Passing particle diameter	5.48 mm

### 安装尺寸图

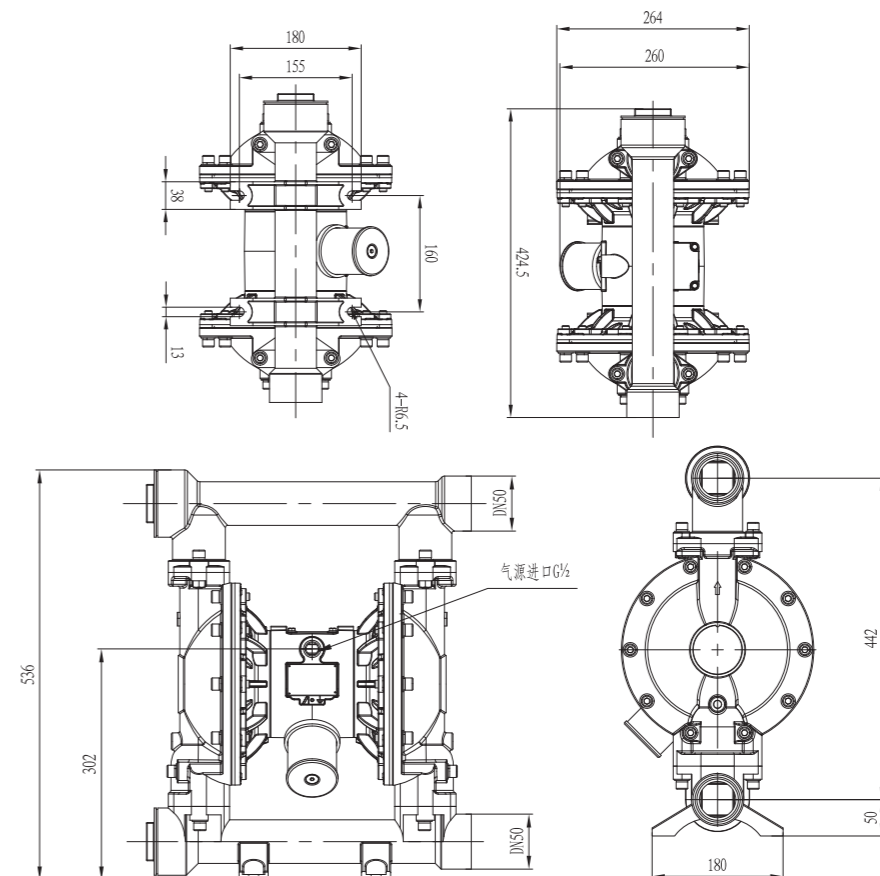

## GDC-80 不锈钢304



### 性能曲线图

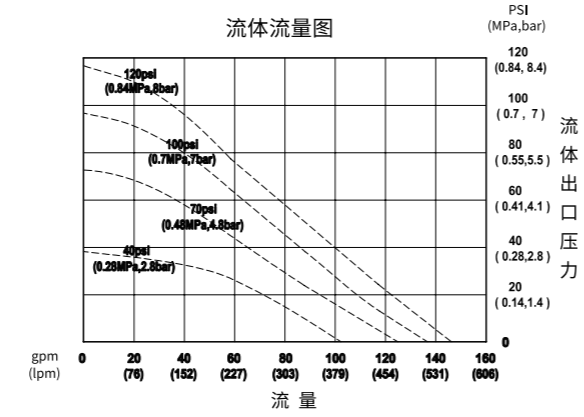

### 规格参数

最大流量 Max. Flow	450 L/min
最大排出压力 Max. discharge pressure	0.7 Mpa
真空度 Vacuum degree	0.05 Mpa

最大空气消耗量 Max. air consumption	252 m <sup>3</sup> /h
吸程 Suction lift	5 m
最大允许颗粒直径 Max. Passing particle diameter	6.3 mm

### 安装尺寸图

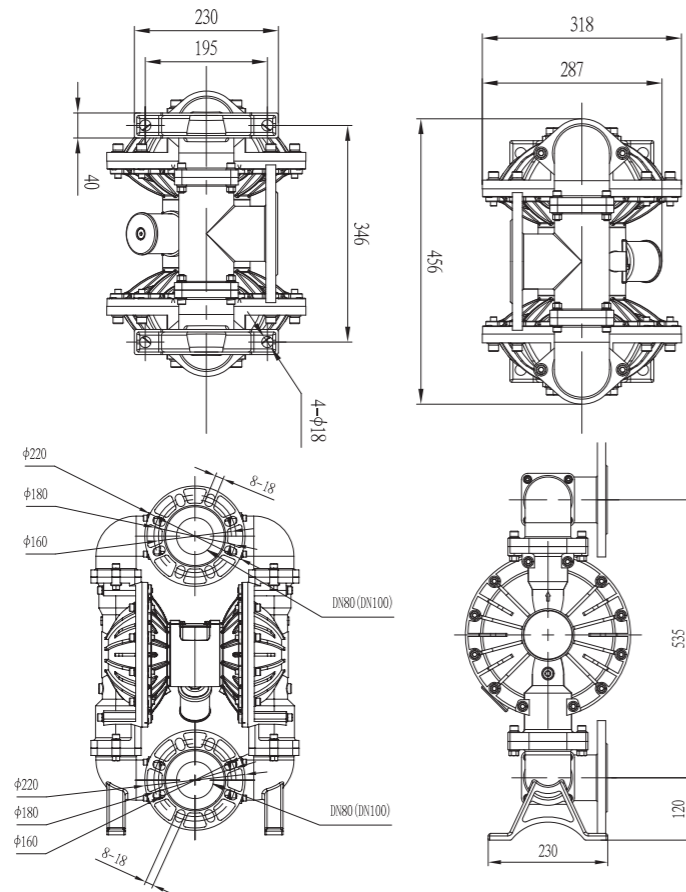

## GDC-125 不锈钢304



### 性能曲线图

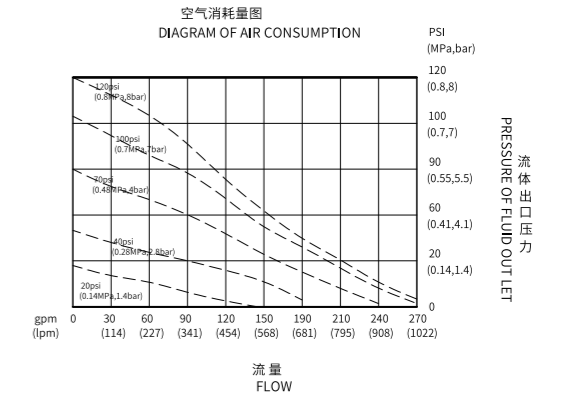

### 规格参数

最大流量 Max. Flow	800 L/min
最大排出压力 Max. discharge pressure	0.7 Mpa
真空度 Vacuum degree	0.05 Mpa

最大空气消耗量 Max. air consumption	468 m <sup>3</sup> /h
吸程 Suction lift	5 m
最大允许颗粒直径 Max. Passing particle diameter	9.4 mm

### 安装尺寸图

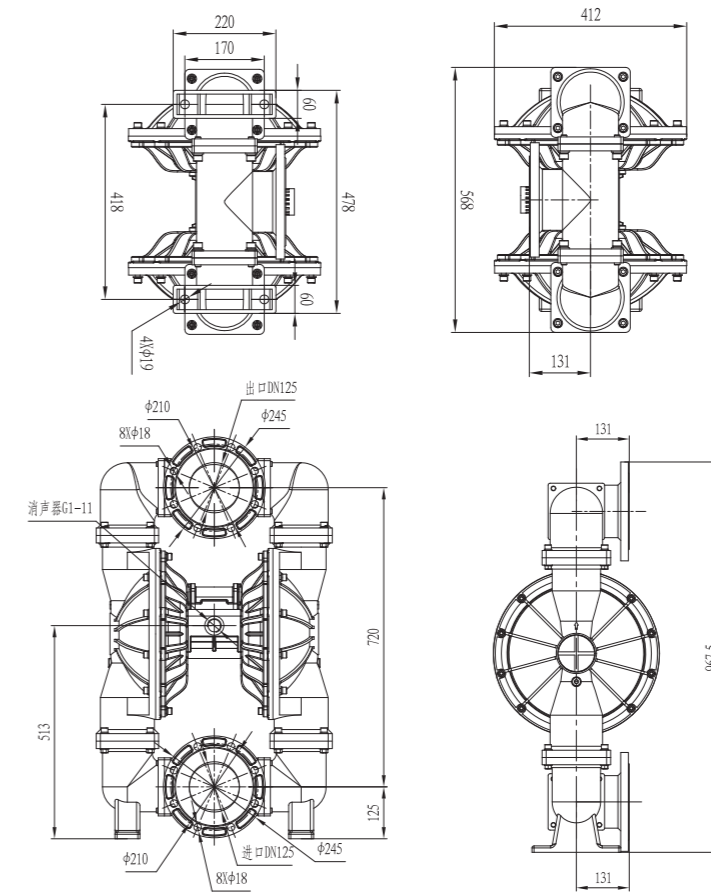

# 06

## Q/DBY3 第三代隔膜泵



## QBY3-10/15 铝合金/不锈钢/铸钢



### 性能曲线图

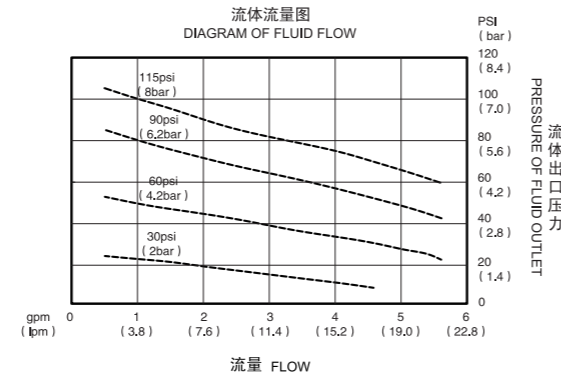

### 规格参数

最大工作流量 Max. Flow	5.8 gpm (22 lpm)	最大虹吸高度 (干抽或湿抽) Max.Suction Height (dry suction or wet suction)	113 ft. (4 m)
最大工作压力 Max. Working Pressure	100 psi (0.7 Mpa, 7 bar)	最大输送固体颗粒 Max. Permitted Grain	0.06 in. (1.5 mm)
流体进口尺寸 Fluid Inlet Size	3/8 in. bsp (f) / 1/2 in. bsp (f)	每往复流量 Every Reciprocating Flow	0.016 gal. (0.06L)
流体出口尺寸 Fluid Outlet Size	3/8 in. bsp (f) / 1/2 in. bsp (f)	最大往复速度 Max. Reciprocating Speed	372cpm
空气进口尺寸 Air Inlet Size	1/4 in. bsp (f)		

### 安装尺寸图

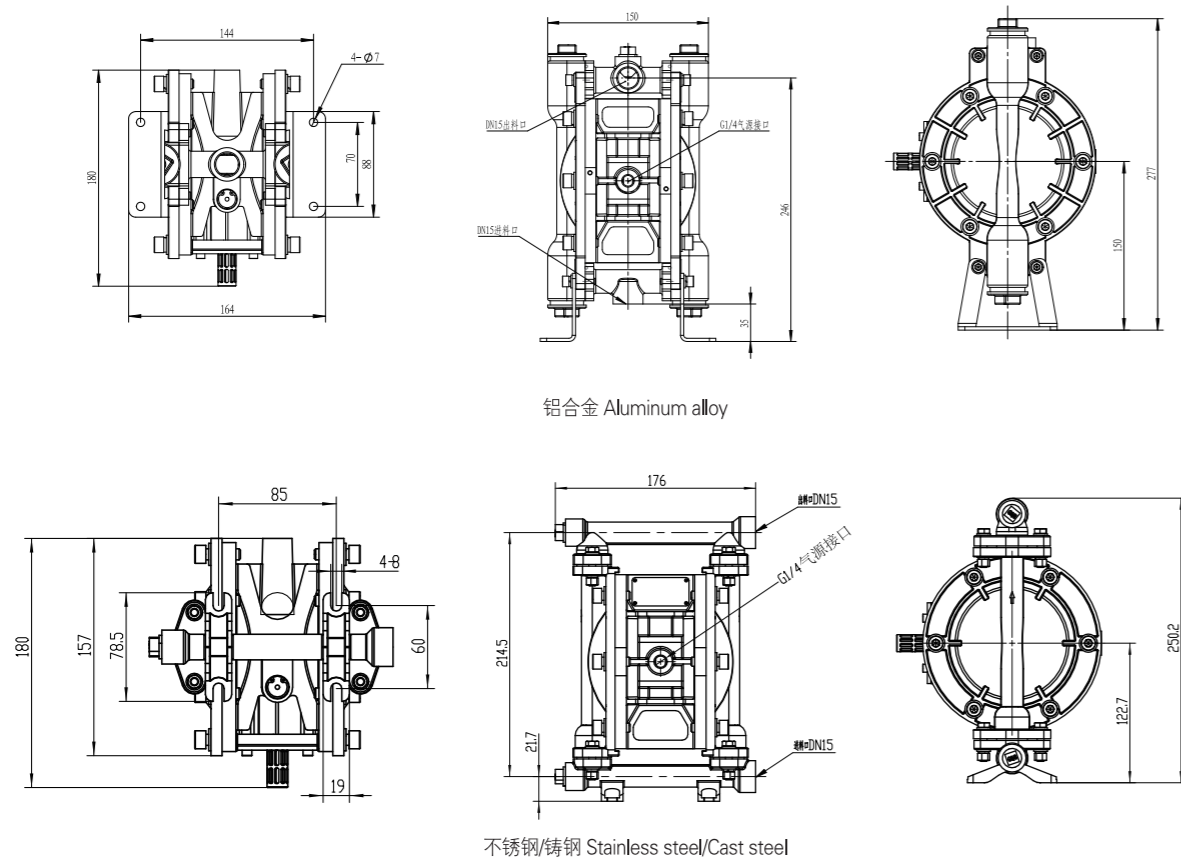

## QBY3-10/15 塑料/氟塑料



### 性能曲线图

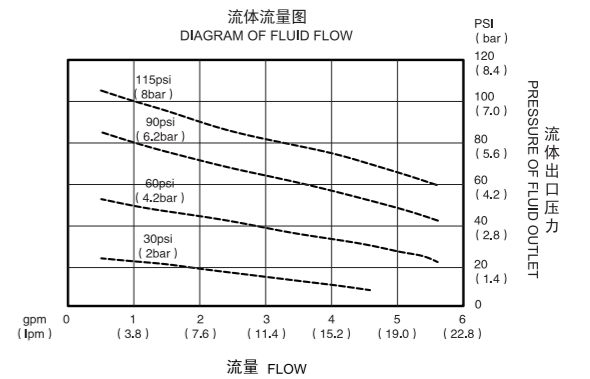

### 规格参数

最大工作流量 Max. Flow	5.8 gpm (22 lpm)	最大虹吸高度 (干抽或湿抽) Max.Suction Height (dry suction or wet suction)	113 ft. (4 m)
最大工作压力 Max. Working Pressure	100 psi (0.7 Mpa, 7 bar)	最大输送固体颗粒 Max. Permitted Grain	0.06 in. (1.5 mm)
流体进口尺寸 Fluid Inlet Size	3/8 in. bsp (f) / 1/2 in. bsp (f)	每往复流量 Every Reciprocating Flow	0.016 gal. (0.06L)
流体出口尺寸 Fluid Outlet Size	3/8 in. bsp (f) / 1/2 in. bsp (f)	最大往复速度 Max. Reciprocating Speed	372cpm
空气进口尺寸 Air Inlet Size	1/4 in. bsp (f)		

### 安装尺寸图

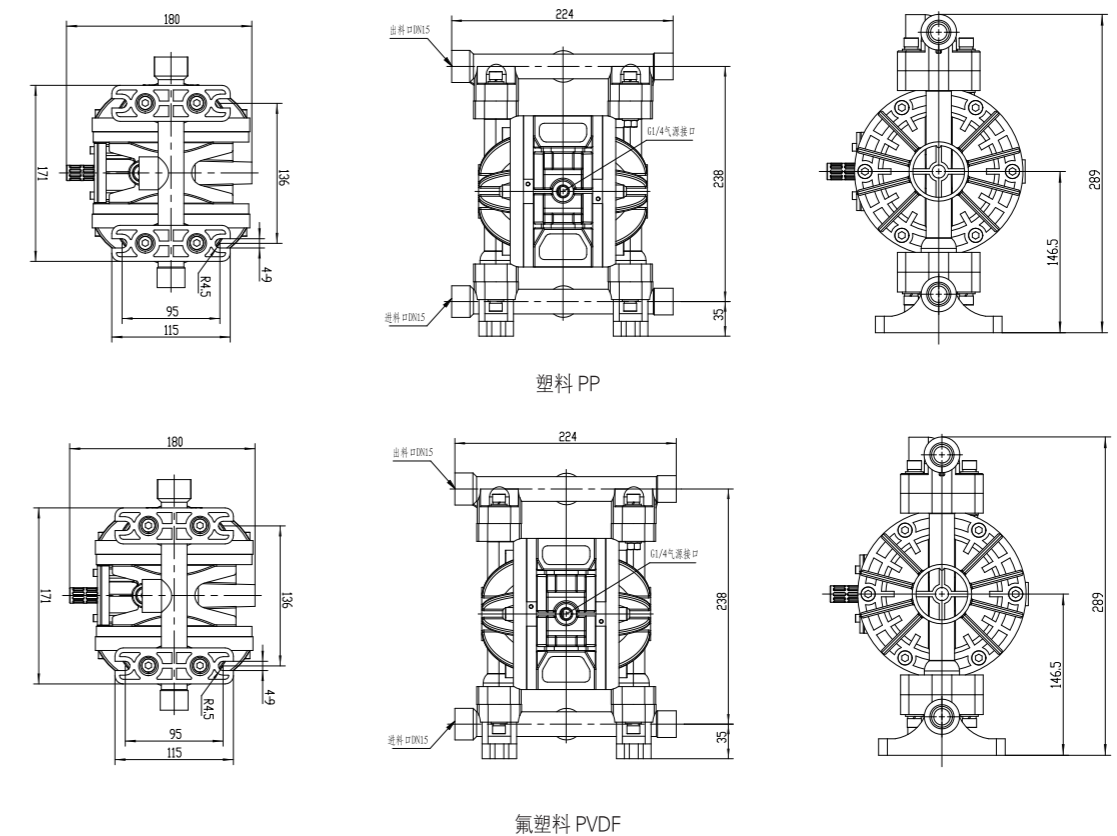

## QBY3-20/25 铝合金/不锈钢/铸钢



### 性能曲线图

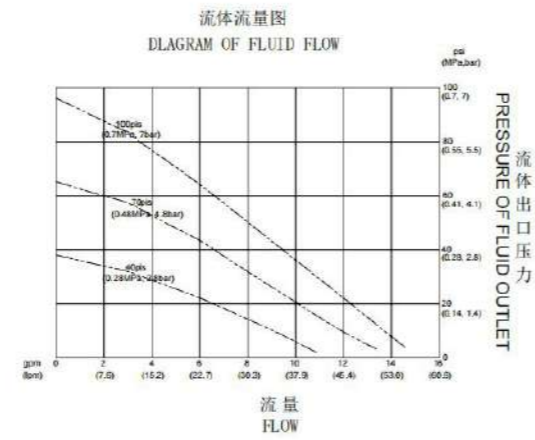

### 规格参数

最大工作流量 Max. Flow	15 gpm (57 lpm)
最大工作压力 Max. Working Pressure	100 psi (0.7 Mpa, 7bar)
流体进口尺寸 Fluid Inlet Size	3/4 in. bsp (f) / 1 in. bsp (f)
流体出口尺寸 Fluid Outlet Size	3/4 in. bsp (f) / 1 in. bsp (f)
空气进口尺寸 Air Inlet Size	1/4 in. bsp (f)

最大虹吸高度 (干抽或湿抽) Max.Suction Height (dry suction or wet suction)	15 ft. (4.5 m)
最大输送固体颗粒 Max. Permitted Grain	3/32 in. (2.5 mm)
每往复流量 Every Reciprocating Flow	0.04 gal. (0.15 L)
最大往复速度 Max. Reciprocating Speed	400 cpm

### 安装尺寸图

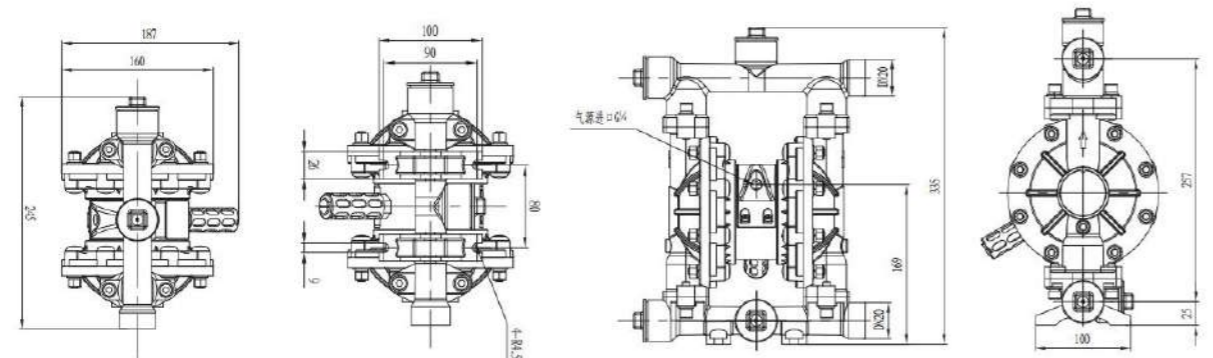

铝合金 Aluminum alloy

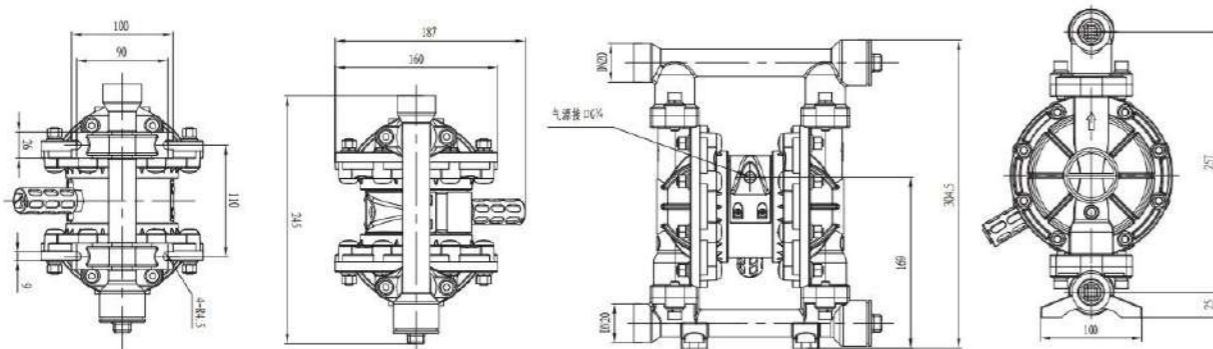

不锈钢/铸钢 Stainless steel/Cast steel

## QBY3-20/25 塑料/氟塑料



### 性能曲线图

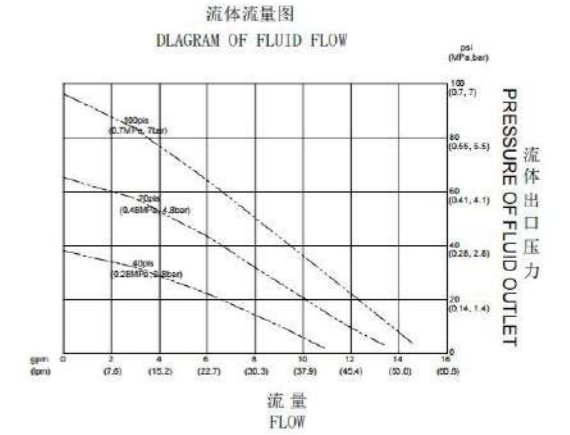

### 规格参数

最大工作流量 Max. Flow	15 gpm (57 lpm)
最大工作压力 Max. Working Pressure	100 psi (0.7 Mpa, 7bar)
流体进口尺寸 Fluid Inlet Size	3/4 in. bsp (f) / 1 in. bsp (f)
流体出口尺寸 Fluid Outlet Size	3/4 in. bsp (f) / 1 in. bsp (f)
空气进口尺寸 Air Inlet Size	1/4 in. bsp (f)

最大虹吸高度 (干抽或湿抽) Max.Suction Height (dry suction or wet suction)	15 ft. (4.5 m)
最大输送固体颗粒 Max. Permitted Grain	3/32 in. (2.5 mm)
每往复流量 Every Reciprocating Flow	0.04 gal. (0.15 L)
最大往复速度 Max. Reciprocating Speed	400 cpm

### 安装尺寸图

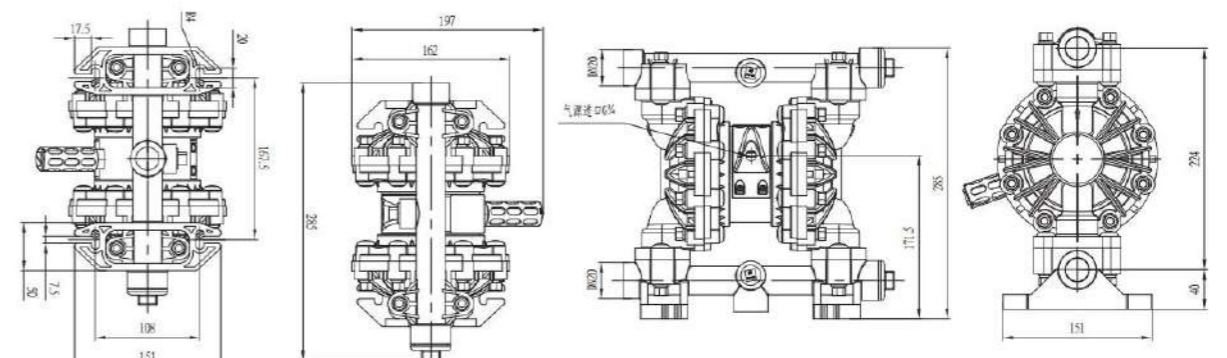

塑料 PP

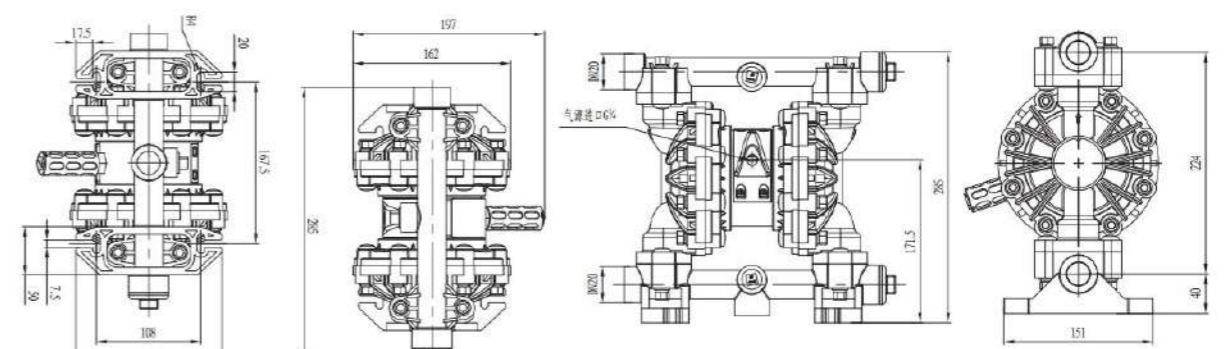

氟塑料 PVDF

## QBY3-32/40 铝合金/不锈钢/球铁



### 性能曲线图

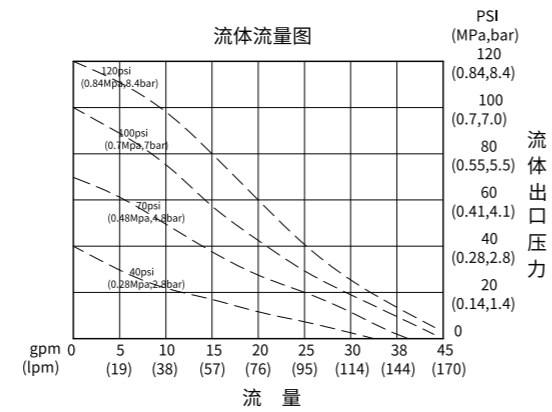

### 规格参数

最大工作流量 Max. Flow	45 gpm (170 lpm)	最大虹吸高度 (干抽或湿抽) Max. Suction Height (dry suction or wet suction)	18 ft. (5.48 m)
最大工作压力 Max. Working Pressure	120 psi (0.84 Mpa, 8.4 bar)	最大输送固体颗粒 Max. Permitted Grain	1/8 in. (3.2 mm)
流体进口尺寸 Fluid Inlet Size	1-1/4 in. bsp (f) / 1-1/2 in. bsp (f)	每往复流量 Every Reciprocating Flow	0.15 gal. (0.57 L)
流体出口尺寸 Fluid Outlet Size	1-1/4 in. bsp (f) / 1-1/2 in. bsp (f)	最大往复速度 Max. Reciprocating Speed	276 cpm
空气进口尺寸 Air Inlet Size	1/2 in. bsp (f)		

### 安装尺寸图

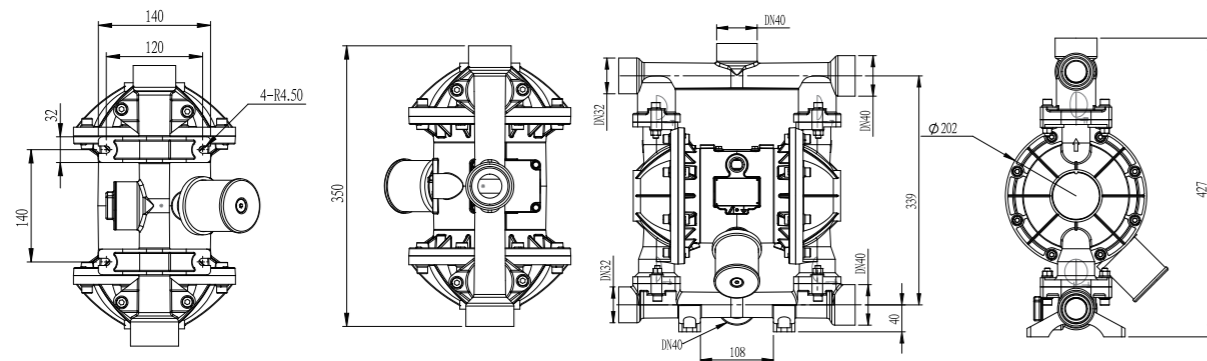

铝合金/不锈钢 Aluminum alloy / Stainless steel

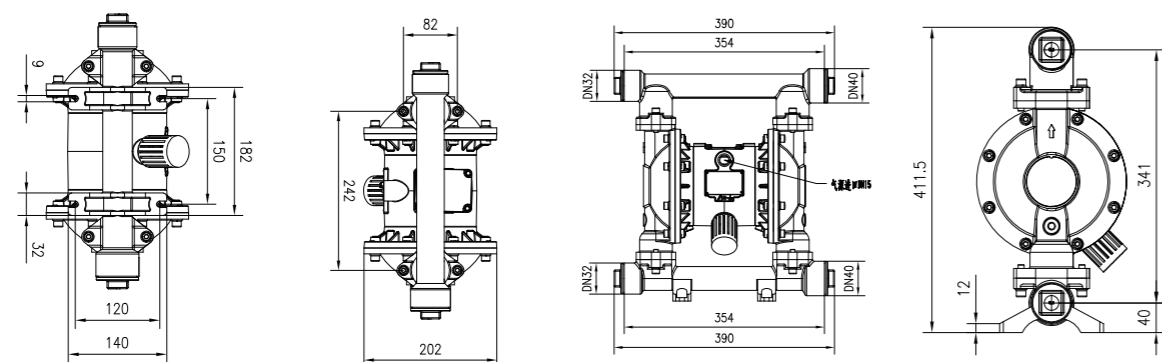

球铁 Nodular cast iron

## QBY3-32/40 塑料/氟塑料/衬氟



### 性能曲线图

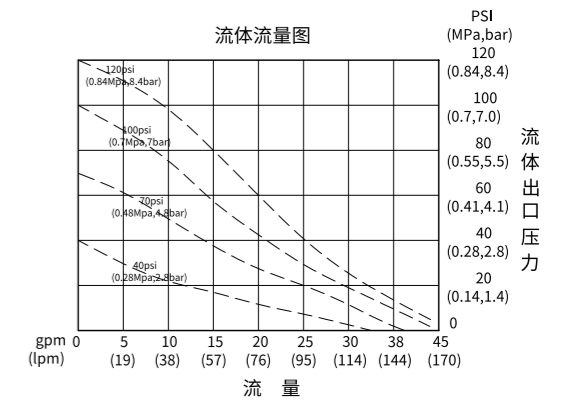

### 规格参数

最大工作流量 Max. Flow	45 gpm (170 lpm)	最大虹吸高度 (干抽或湿抽) Max. Suction Height (dry suction or wet suction)	18 ft. (5.48 m)
最大工作压力 Max. Working Pressure	120 psi (0.84 Mpa, 8.4 bar)	最大输送固体颗粒 Max. Permitted Grain	1/8 in. (3.2 mm)
流体进口尺寸 Fluid Inlet Size	1-1/4 in. bsp (f) / 1-1/2 in. bsp (f)	每往复流量 Every Reciprocating Flow	0.15 gal. (0.57 L)
流体出口尺寸 Fluid Outlet Size	1-1/4 in. bsp (f) / 1-1/2 in. bsp (f)	最大往复速度 Max. Reciprocating Speed	276 cpm
空气进口尺寸 Air Inlet Size	1/2 in. bsp (f)		

### 安装尺寸图

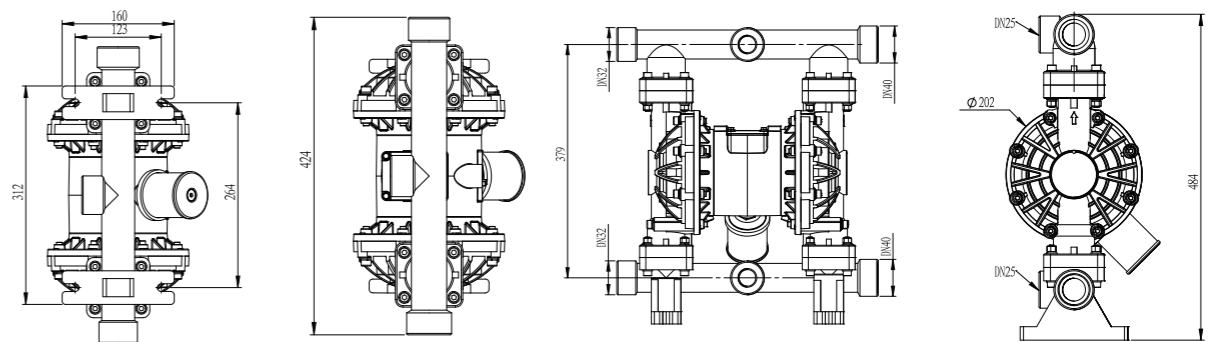

塑料/氟塑料 PP/PVDF

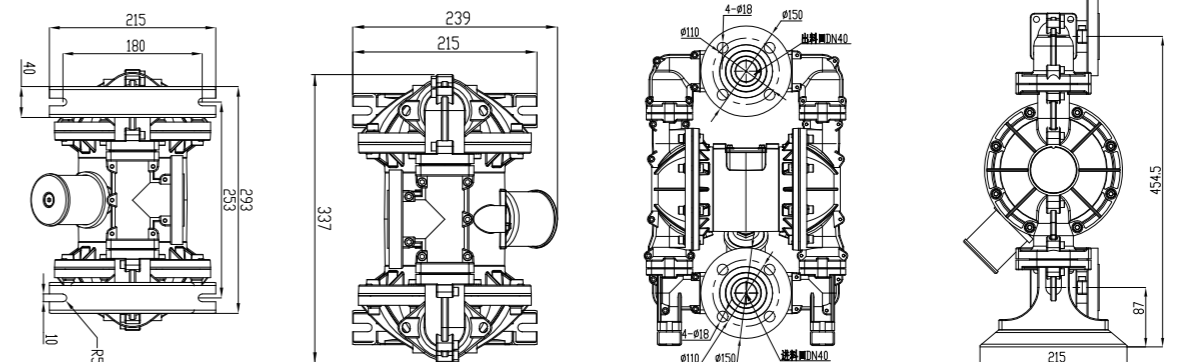

衬氟 Lining PVDF

## QBY3-50/65 铝合金/不锈钢/球铁



### 性能曲线图

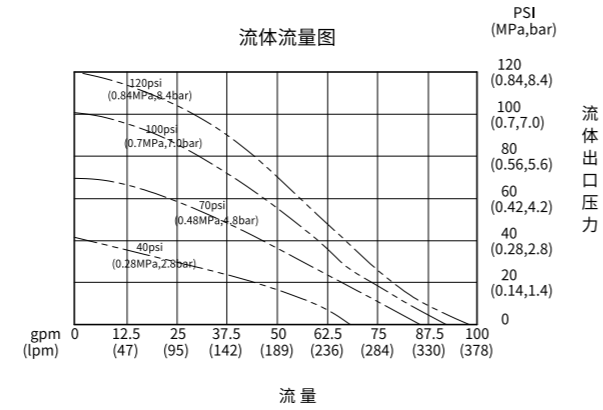

### 规格参数

最大工作流量 Max. Flow	100 gpm (378.5 lpm)	最大虹吸高度 (干抽或湿抽) Max. Suction Height (dry suction or wet suction)	18 ft. (5.48 m)
最大工作压力 Max. Working Pressure	120 psi (0.84 Mpa, 8.4 bar)	最大输送固体颗粒 Max. Permitted Grain	3/16 in. (4.8 mm)
流体进口尺寸 Fluid Inlet Size	2 in. bsp (f) / 2-1/2 in. bsp (f)	每往复流量 Every Reciprocating Flow	0.5 gal. (1.9 L)
流体出口尺寸 Fluid Outlet Size	2 in. bsp (f) / 2-1/2 in. bsp (f)	最大往复速度 Max. Reciprocating Speed	200 cpm
空气进口尺寸 Air Inlet Size	1/2 in. bsp (f)		

### 安装尺寸图

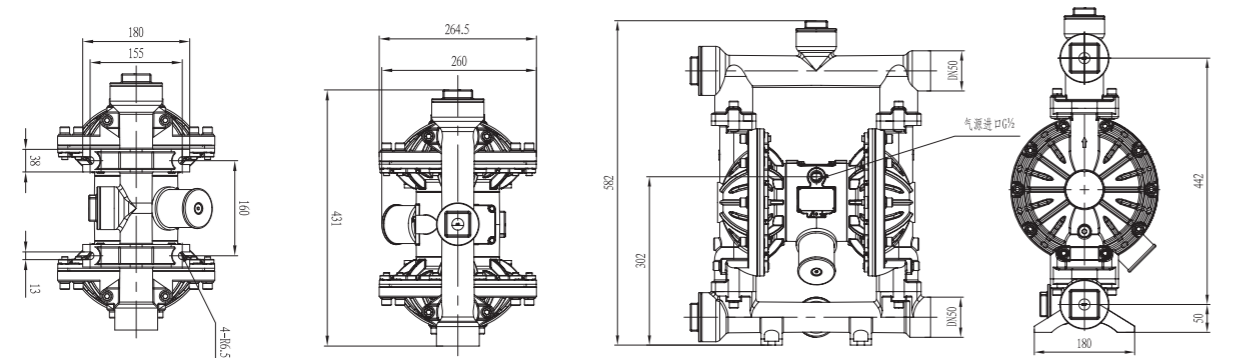

铝合金 Aluminum alloy

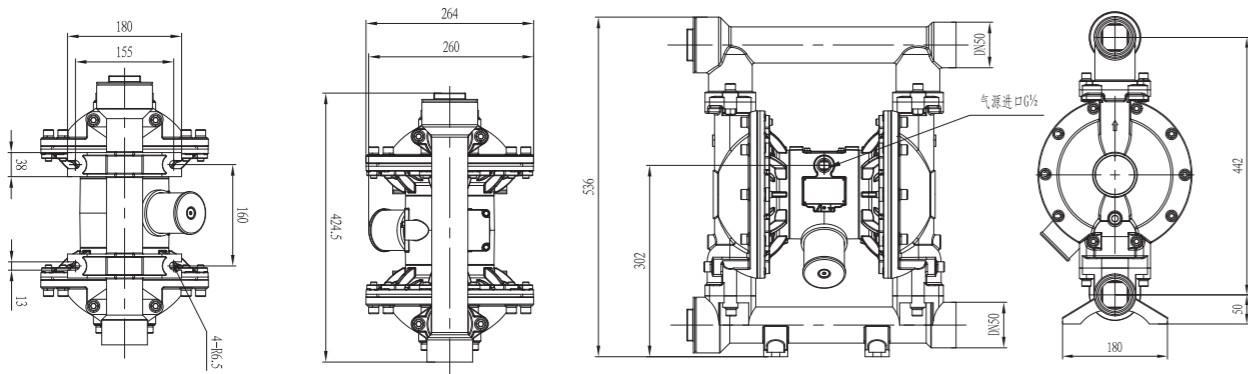

不锈钢/球铁 Stainless steel/Nodular cast iron

## QBY3-50/65 塑料/氟塑料/衬氟



### 性能曲线图

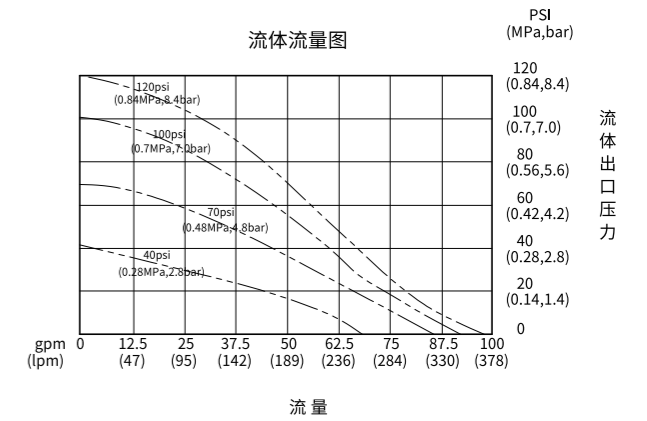

### 规格参数

最大工作流量 Max. Flow	100 gpm (378.5 lpm)	最大虹吸高度 (干抽或湿抽) Max. Suction Height (dry suction or wet suction)	18 ft. (5.48 m)
最大工作压力 Max. Working Pressure	120 psi (0.84 Mpa, 8.4 bar)	最大输送固体颗粒 Max. Permitted Grain	3/16 in. (4.8 mm)
流体进口尺寸 Fluid Inlet Size	2 in. bsp (f) / 2-1/2 in. bsp (f)	每往复流量 Every Reciprocating Flow	0.5 gal. (1.9 L)
流体出口尺寸 Fluid Outlet Size	2 in. bsp (f) / 2-1/2 in. bsp (f)	最大往复速度 Max. Reciprocating Speed	200 cpm
空气进口尺寸 Air Inlet Size	1/2 in. bsp (f)		

### 安装尺寸图

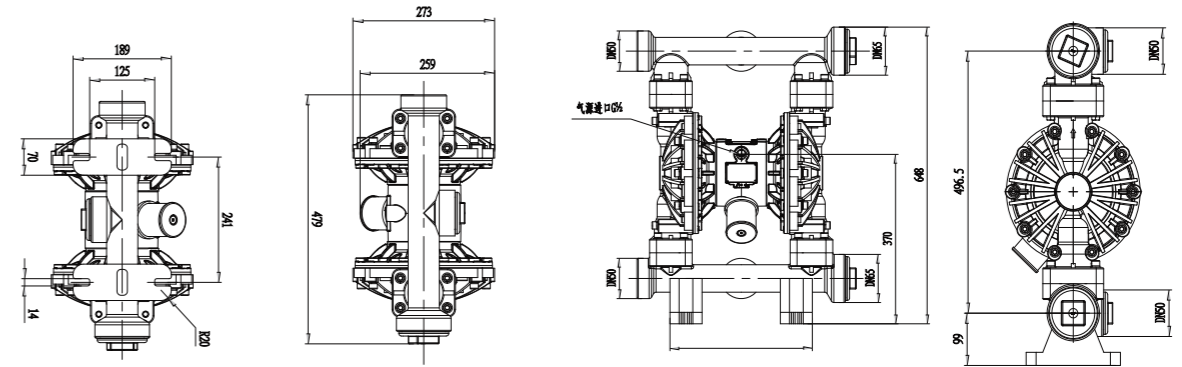

塑料/氟塑料 PP/PVDF

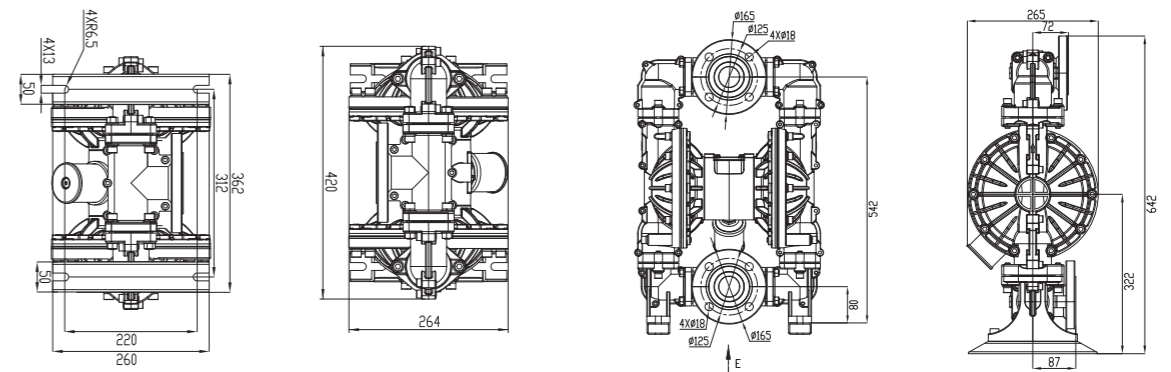

衬氟 Lining PVDF



# QBY3-125 铝合金/不锈钢/球铁



## 性能曲线图

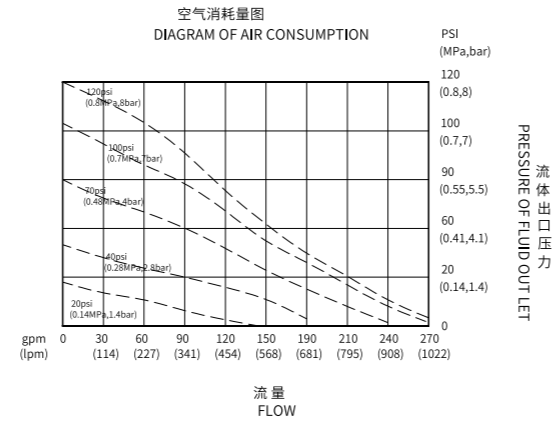

## 规格参数

最大工作流量 Max. Flow	275 gpm (1041 lpm)
最大工作压力 Max. Working Pressure	120 psi (0.84 Mpa, 8.4 bar)
流体进口尺寸 Fluid Inlet Size	5 in. bsp (f)
流体出口尺寸 Fluid Outlet Size	5 in. bsp (f)
空气进口尺寸 Air Inlet Size	3/4 in. bsp (f)

最大虹吸高度 (干抽或湿抽) Max.Suction Height (dry suction or wet suction)	25 ft. (7.6 m)
最大输送固体颗粒 Max. Permitted Grain	3/8 in. ( 9.4 mm )
每往复流量 Every Reciprocating Flow	2.0 gal. (7.6 L)
最大往复速度 Max. Reciprocating Speed	135 cpm

## 安装尺寸图

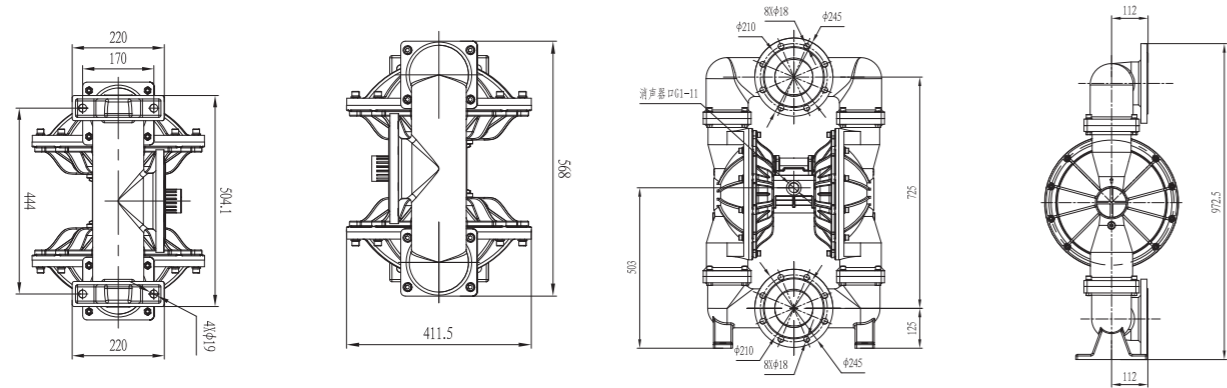

铝合金/不锈钢 Aluminum alloy / Stainless steel

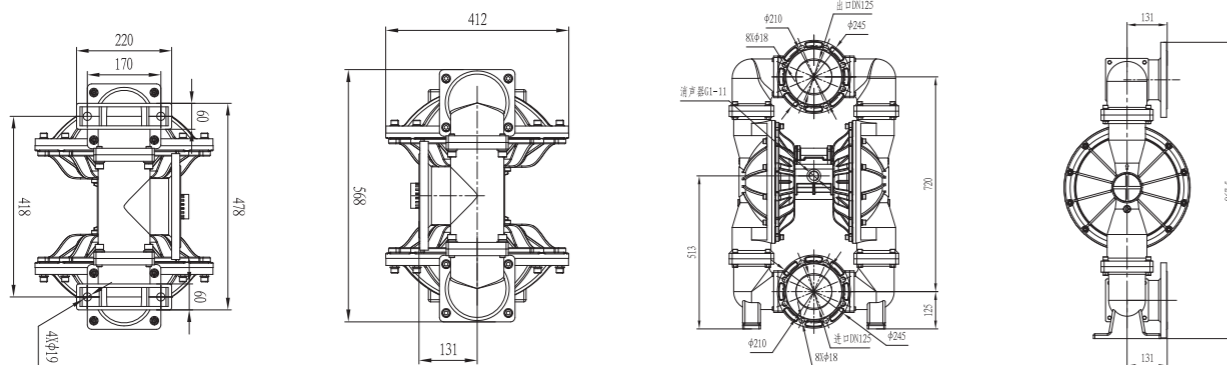

球铁 Nodular cast iron

# QBY3-125 塑料/氟塑料/衬氟



## 性能曲线图

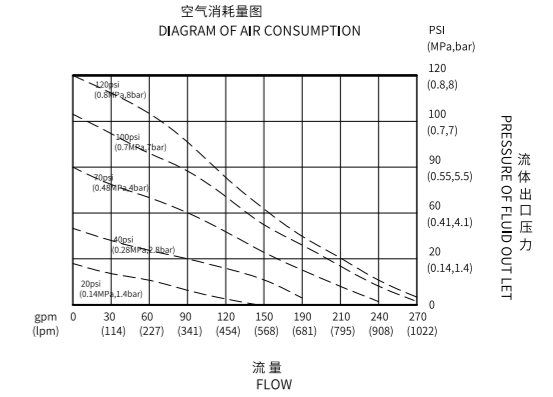

## 规格参数

最大工作流量 Max. Flow	275 gpm (1041 lpm)
最大工作压力 Max. Working Pressure	120 psi (0.84 Mpa, 8.4 bar)
流体进口尺寸 Fluid Inlet Size	5 in. bsp (f)
流体出口尺寸 Fluid Outlet Size	5 in. bsp (f)
空气进口尺寸 Air Inlet Size	3/4 in. bsp (f)

最大虹吸高度 (干抽或湿抽) Max.Suction Height (dry suction or wet suction)	25 ft. (7.6 m)
最大输送固体颗粒 Max. Permitted Grain	3/8 in. ( 9.4 mm )
每往复流量 Every Reciprocating Flow	2.0 gal. (7.6 L)
最大往复速度 Max. Reciprocating Speed	135 cpm

## 安装尺寸图

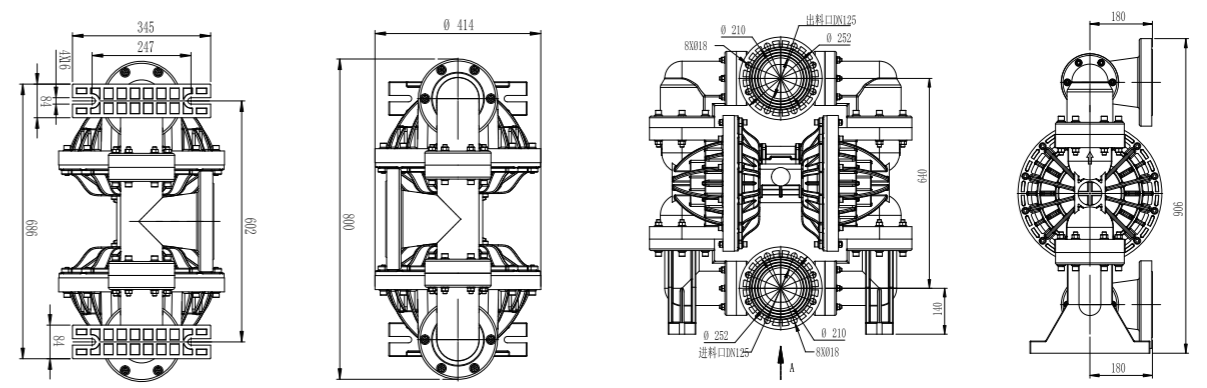

塑料/氟塑料 PP/PVDF

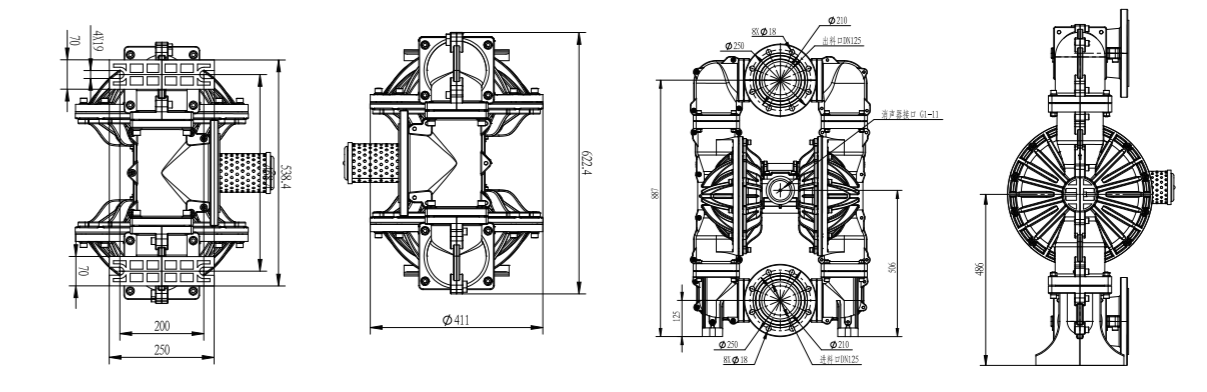

衬氟 Lining PVDF

## QBY3-25TTTT 全特氟龙



### 性能曲线图

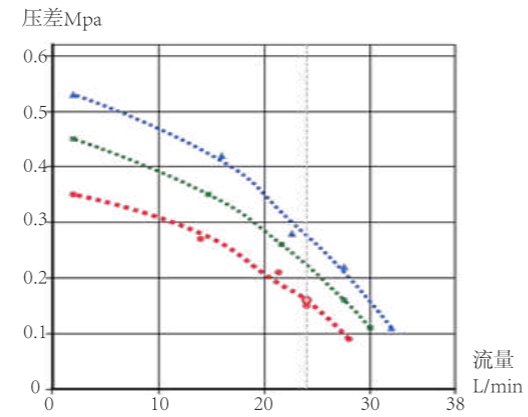

### 规格参数

最大工作流量 Max. Flow	32 L/min	最大虹吸高度 (干抽或湿抽) Max.Suction Height (dry suction or wet suction)	2.5m
最大工作压力 Max. Working Pressure	100 psi (0.7 Mpa, 7bar)	最大输送固体颗粒 Max. Permitted Grain	3/32 in. (2.5 mm)
流体进口尺寸 Fluid Inlet Size	1 in. bsp (f)	每往复流量 Every Reciprocating Flow	0.04 gal. (0.15 L)
流体出口尺寸 Fluid Outlet Size	1 in. bsp (f)	最大往复速度 Max. Reciprocating Speed	400 cpm
空气进口尺寸 Air Inlet Size	1/4 in. bsp (f)		

### 安装尺寸图

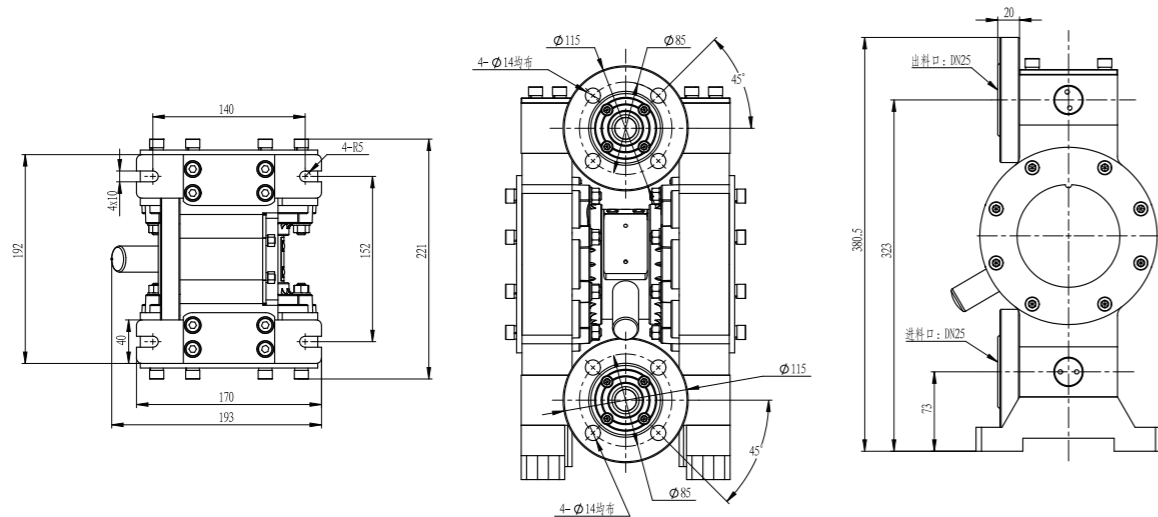

## QBY3-40TTTT 全特氟龙



### 性能曲线图

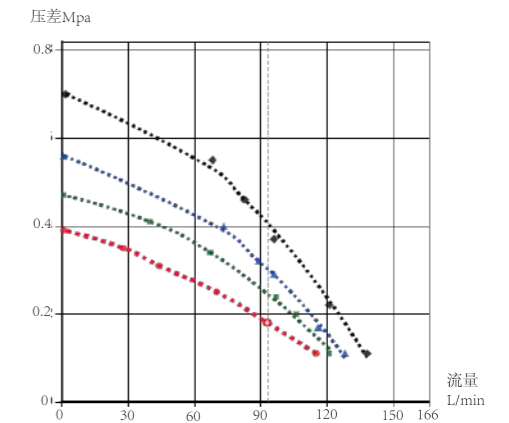

### 规格参数

最大工作流量 Max. Flow	142 L/min	最大虹吸高度 (干抽或湿抽) Max.Suction Height (dry suction or wet suction)	3.5m
最大工作压力 Max. Working Pressure	120 psi (0.84 Mpa, 8.4 bar)	最大输送固体颗粒 Max. Permitted Grain	1/8 in. (3.2 mm)
流体进口尺寸 Fluid Inlet Size	1-1/2 in. bsp (f)	每往复流量 Every Reciprocating Flow	0.15 gal. (0.57 L)
流体出口尺寸 Fluid Outlet Size	1-1/2 in. bsp (f)	最大往复速度 Max. Reciprocating Speed	276 cpm
空气进口尺寸 Air Inlet Size	1/2 in. bsp (f)		

### 安装尺寸图

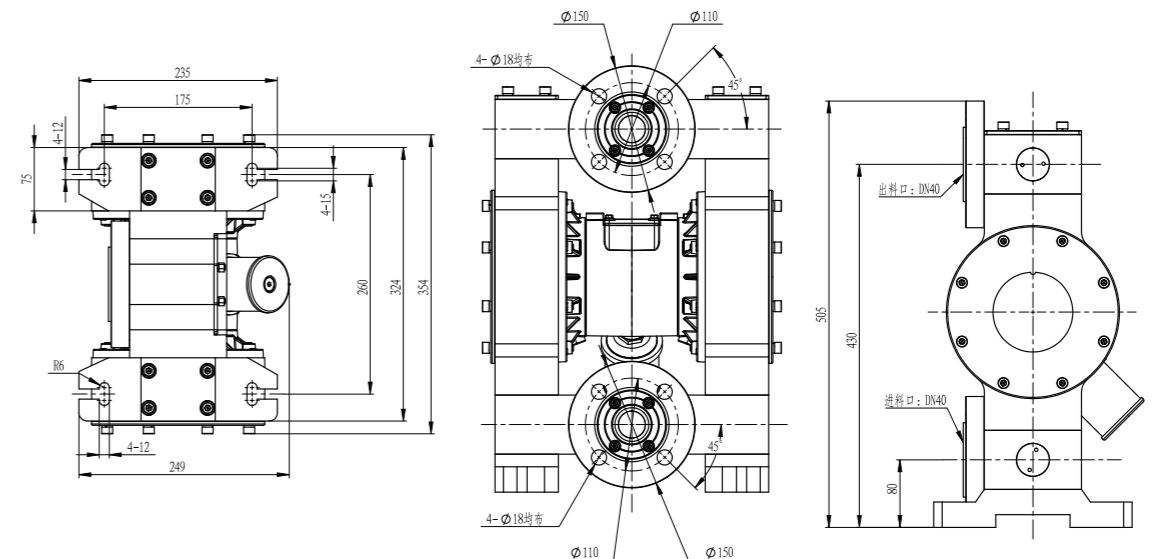

## DBY3-10/15 铝合金/不锈钢/球铁

### 性能曲线图

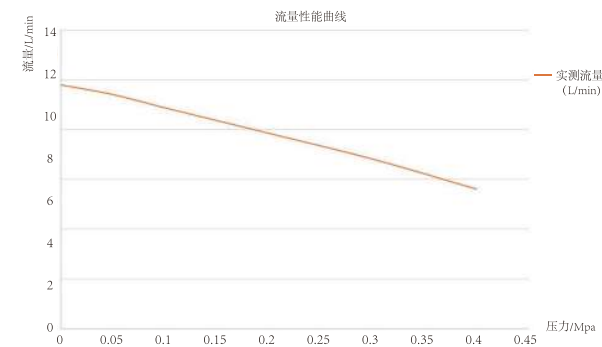

### 规格参数

最大工作流量 Max.Flow	3.4gpm ( 12.8Lpm )	最大输送固体颗粒 Max.Permitted Grain	3/32in.(2.5mm)
最大工作压力 Max.Working Pressure	0.4Mpa / 0.7Mpa	每往复流量 Every Reciprocating Flow	0.04gallon(0.15L)
流体进口尺寸 Fluid Inlet Size	1/2in.bsp ( f )	最大往复速度 Max.Reciprocating Speed	85cpm
流体出口尺寸 Fluid Outlet Size	1/2in.bsp ( f )	出口压力 Outlet Pressure	0.4Mpa / 0.7Mpa
最大虹吸高度(干抽或湿抽)		电机功率 Motor power	0.55kw / 0.75kw
Max.Suction height(dry suction or wet suction)	10ft.(3m )		

### 安装尺寸图

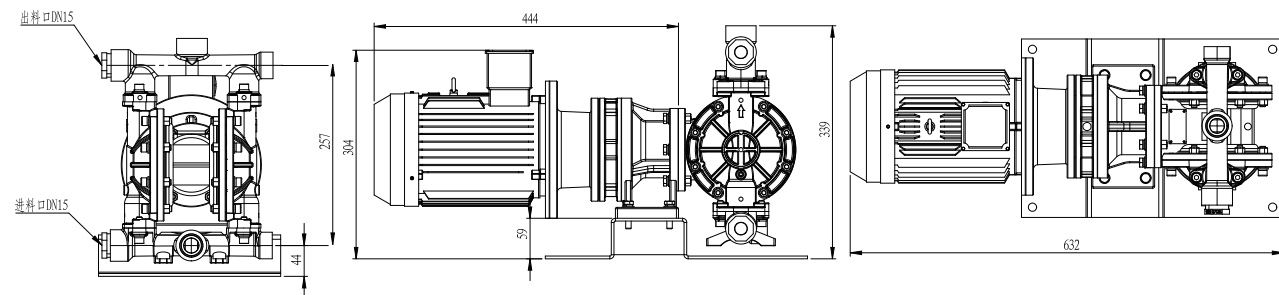

铝合金 Aluminum alloy

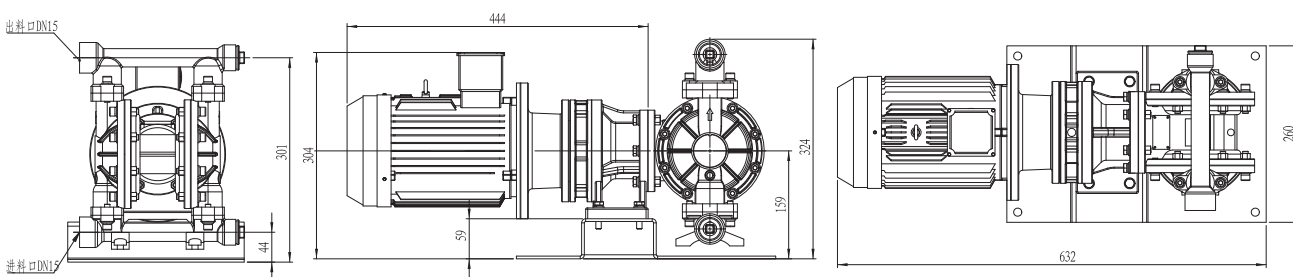

不锈钢/球铁 Stainless steel/Nodular cast iron

## DBY3-10/15 塑料/氟塑料

### 性能曲线图

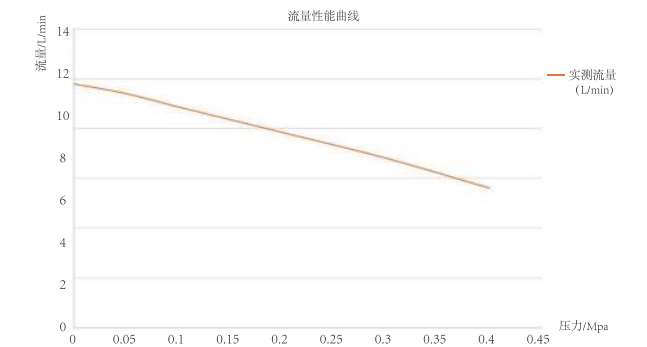
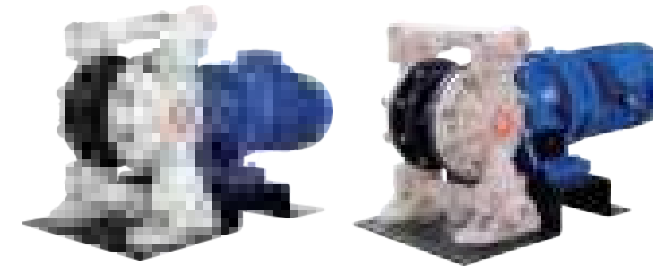

### 规格参数

最大工作流量 Max.Flow	3.4gpm ( 12.8Lpm )	最大输送固体颗粒 Max.Permitted Grain	3/32in.(2.5mm)
最大工作压力 Max.Working Pressure	0.4Mpa / 0.7Mpa	每往复流量 Every Reciprocating Flow	0.04gallon(0.15L)
流体进口尺寸 Fluid Inlet Size	1/2in.bsp ( f )	最大往复速度 Max.Reciprocating Speed	85cpm
流体出口尺寸 Fluid Outlet Size	1/2in.bsp ( f )	出口压力 Outlet Pressure	0.4Mpa / 0.7Mpa
最大虹吸高度(干抽或湿抽)		电机功率 Motor power	0.55kw / 0.75kw
Max.Suction height(dry suction or wet suction)	10ft.(3m )		

### 安装尺寸图

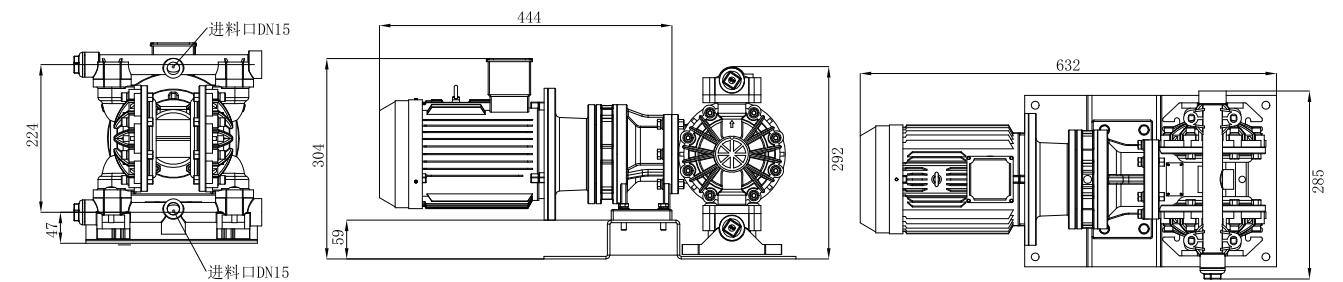

塑料 PP

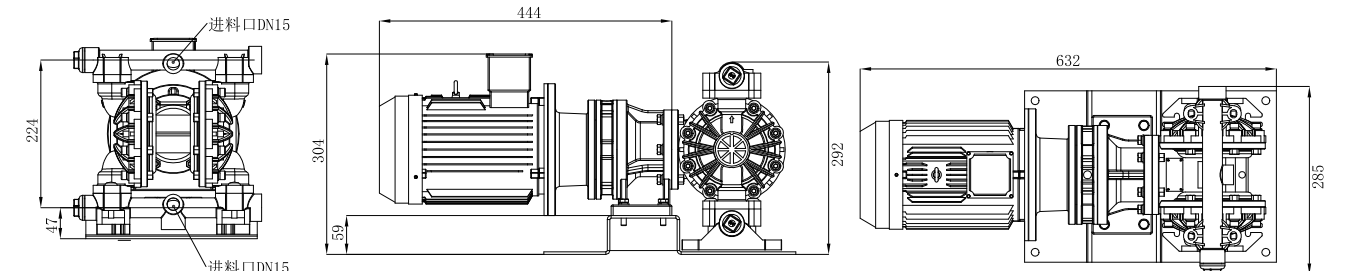

氟塑料 PVDF

## DBY3-20/25 铝合金/不锈钢/球铁



### 性能曲线图

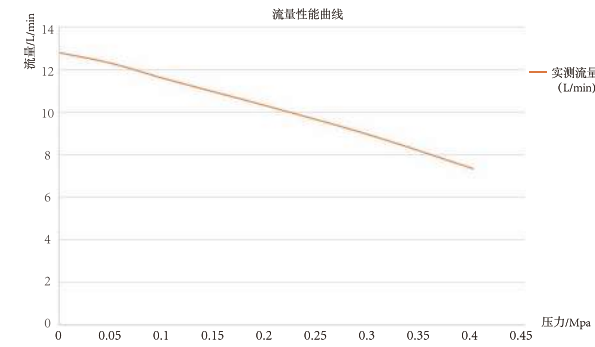

### 规格参数

最大工作流量 Max.Flow	3.4gpm ( 12.8Lpm )	最大输送固体颗粒 Max.Permitted Grain	3/32in.(2.5mm)
最大工作压力 Max.Working Pressure	0.4Mpa / 0.7Mpa	每往复流量 Every Reciprocating Flow	0.04gallon(0.15L)
流体进口尺寸 Fluid Inlet Size	3/4in.bsp ( f )	最大往复速度 Max.Reciprocating Speed	85cpm
流体出口尺寸 Fluid Outlet Size	3/4in.bsp ( f )	出口压力 Outlet Pressure	0.4Mpa / 0.7Mpa
最大虹吸高度(干抽或湿抽)		电机功率 Motor power	0.55kw / 0.75kw
Max.Suction height(dry suction or wet suction)	10ft.(3m )		

### 安装尺寸图

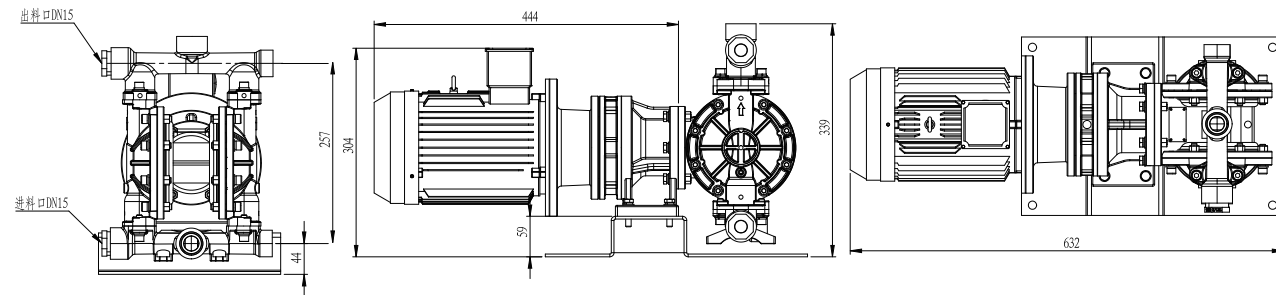

铝合金 Aluminum alloy

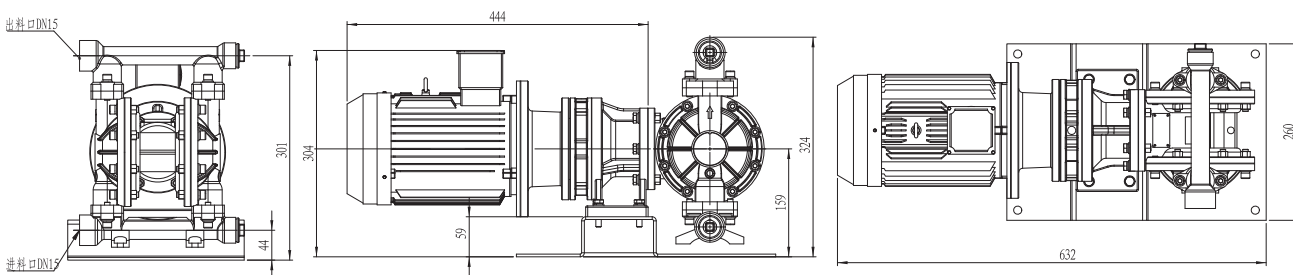

不锈钢/球铁 Stainless steel/Nodular cast iron

## DBY3-20/25 塑料/氟塑料

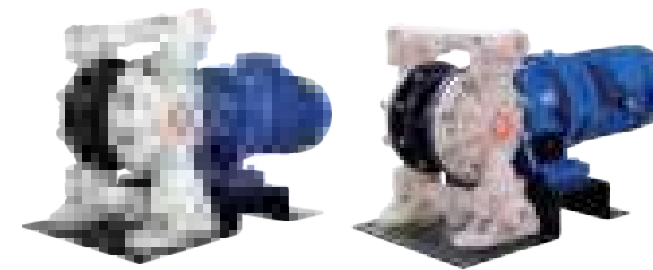

### 性能曲线图

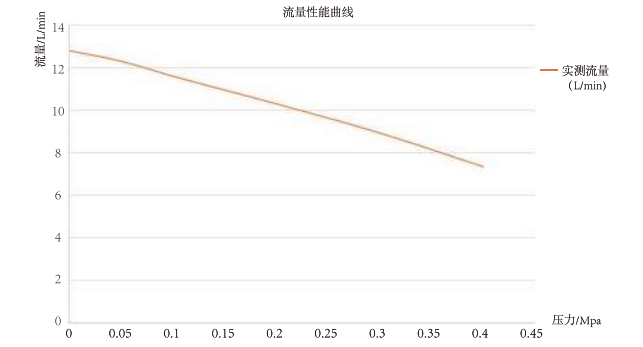

### 规格参数

最大工作流量 Max.Flow	3.4gpm ( 12.8Lpm )	最大输送固体颗粒 Max.Permitted Grain	3/32in.(2.5mm)
最大工作压力 Max.Working Pressure	0.4Mpa / 0.7Mpa	每往复流量 Every Reciprocating Flow	0.04gallon(0.15L)
流体进口尺寸 Fluid Inlet Size	3/4in.bsp ( f )	最大往复速度 Max.Reciprocating Speed	85cpm
流体出口尺寸 Fluid Outlet Size	3/4in.bsp ( f )	出口压力 Outlet Pressure	0.4Mpa / 0.7Mpa
最大虹吸高度(干抽或湿抽)		电机功率 Motor power	0.55kw / 0.75kw
Max.Suction height(dry suction or wet suction)	10ft.(3m )		

### 安装尺寸图

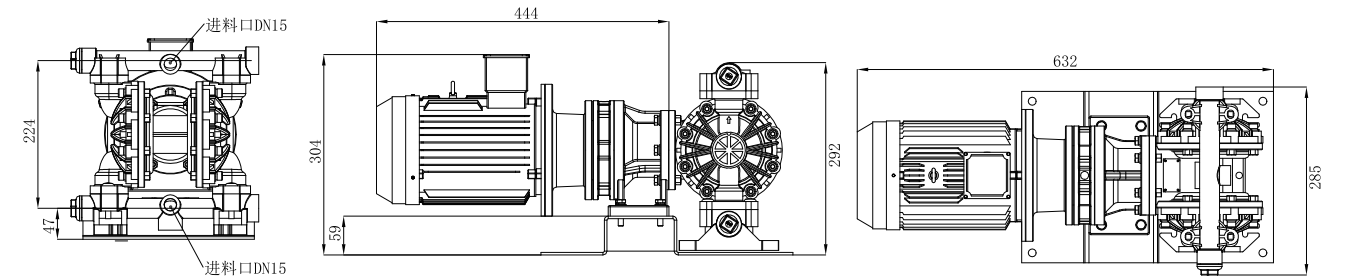

塑料 PP

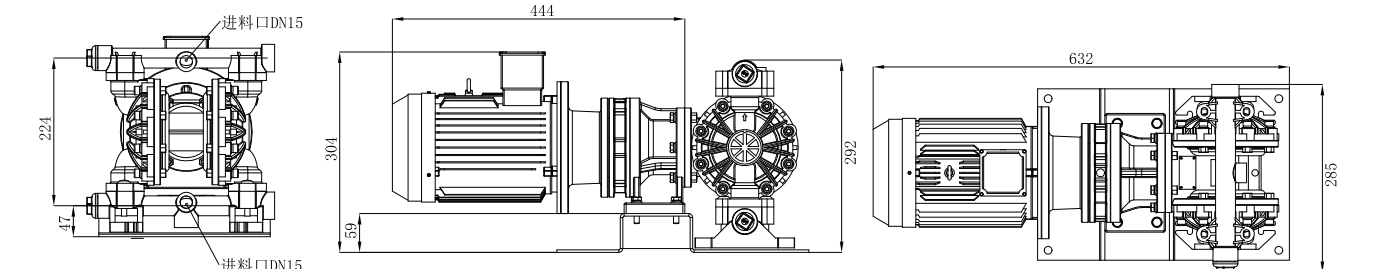

氟塑料 PVDF

## DBY3-32/40 铝合金/不锈钢/球铁



### 性能曲线图

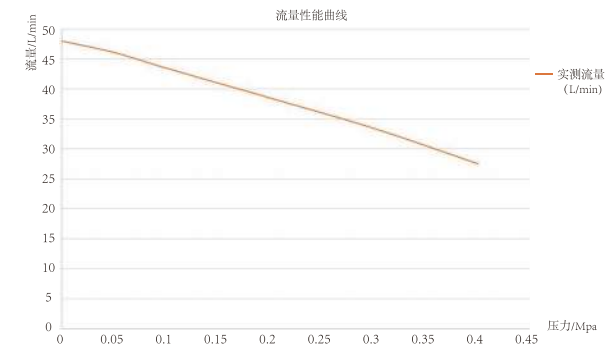

### 规格参数

最大工作流量 Max.Flow	12.7gpm ( 48Lpm )	最大输送固体颗粒 Max.Permitted Grain	1/8in.(3.2mm)
最大工作压力 Max.Working Pressure	0.4Mpa / 0.7Mpa	每往复流量 Every Reciprocating Flow	0.15gallon(0.57L)
流体进口尺寸 Fluid Inlet Size	1-1/2in.bsp ( f )	最大往复速度 Max.Reciprocating Speed	85cpm
流体出口尺寸 Fluid Outlet Size	1-1/2in.bsp ( f )	出口压力 Outlet Pressure	0.4Mpa / 0.7Mpa
最大虹吸高度(干抽或湿抽)		电机功率 Motor power	1.5kw / 2.2kw
Max.Suction height(dry suction or wet suction)	13ft.(4m )		

### 安装尺寸图

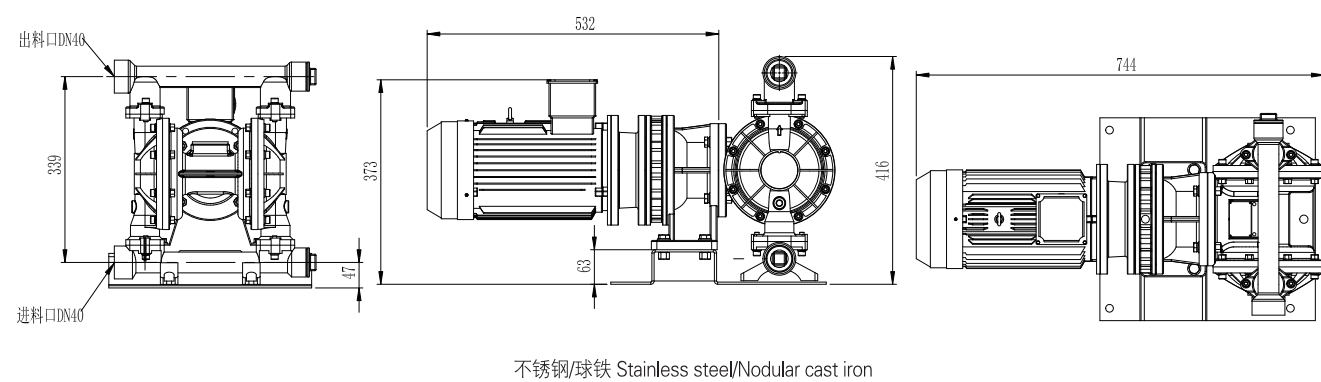
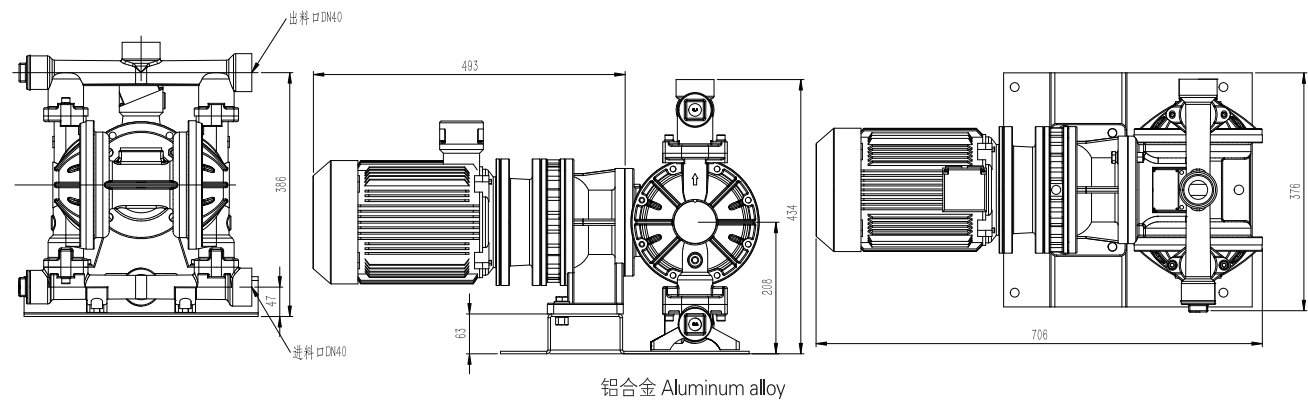

## DBY3-32/40 塑料/氟塑料/衬氟

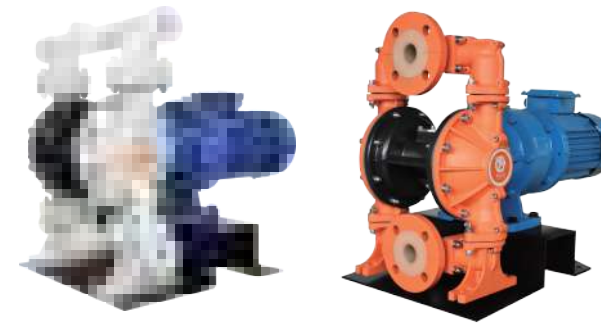

### 性能曲线图

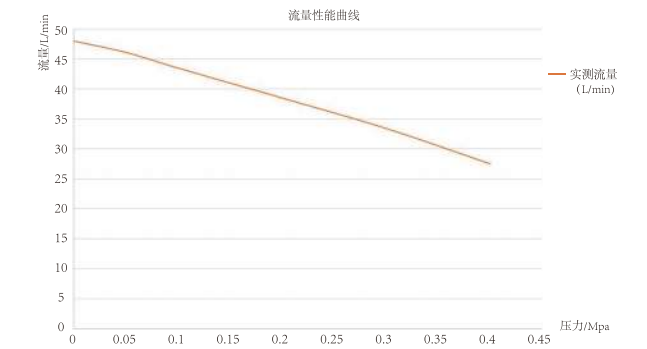

### 规格参数

最大工作流量 Max.Flow	12.7gpm ( 48Lpm )	最大输送固体颗粒 Max.Permitted Grain	1/8in.(3.2mm)
最大工作压力 Max.Working Pressure	0.4Mpa / 0.7Mpa	每往复流量 Every Reciprocating Flow	0.15gallon(0.57L)
流体进口尺寸 Fluid Inlet Size	1-1/2in.bsp ( f )	最大往复速度 Max.Reciprocating Speed	85cpm
流体出口尺寸 Fluid Outlet Size	1-1/2in.bsp ( f )	出口压力 Outlet Pressure	0.4Mpa / 0.7Mpa
最大虹吸高度(干抽或湿抽)		电机功率 Motor power	1.5kw / 2.2kw
Max.Suction height(dry suction or wet suction)	13ft.(4m )		

### 安装尺寸图

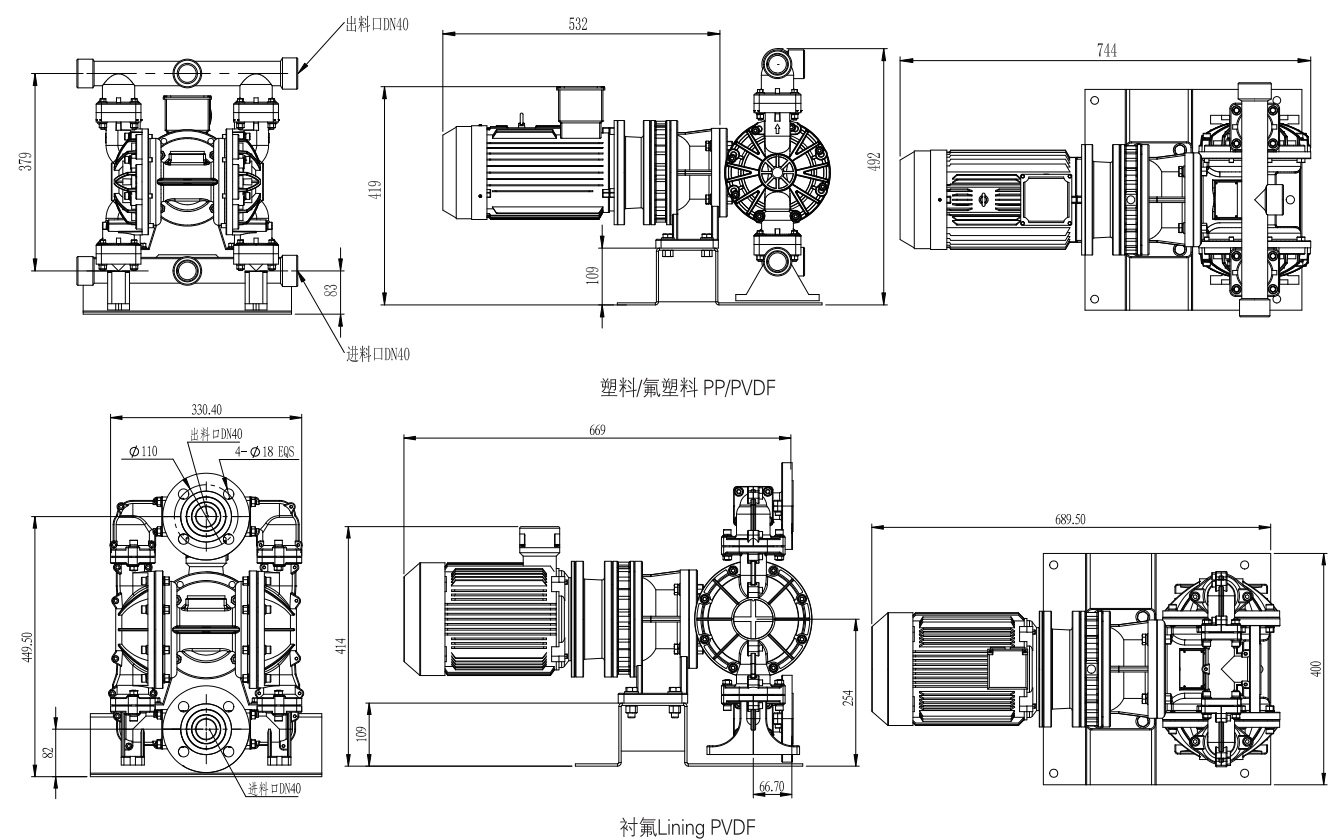

## DBY3-50/65 铝合金/不锈钢/球铁



### 性能曲线图



### 规格参数

最大工作流量 Max.Flow	42.8gpm ( 162lpm )	最大输送固体颗粒 Max.Permitted Grain	3/16in.(4.8mm)
最大工作压力 Max.Working Pressure	0.4Mpa / 0.7Mpa	每往复流量 Every Reciprocating Flow	0.5gallon(1.9L)
流体进口尺寸 Fluid Inlet Size	2in.bsp ( f )	最大往复速度 Max.Reciprocating Speed	85cpm
流体出口尺寸 Fluid Outlet Size	2in.bsp ( f )	出口压力 Outlet Pressure	0.4Mpa / 0.7Mpa
最大虹吸高度(干抽或湿抽)		电机功率 Motor power	2.2kw / 3kw
Max.Suction height(dry suction or wet suction)	16.4ft.(5m )		

### 安装尺寸图

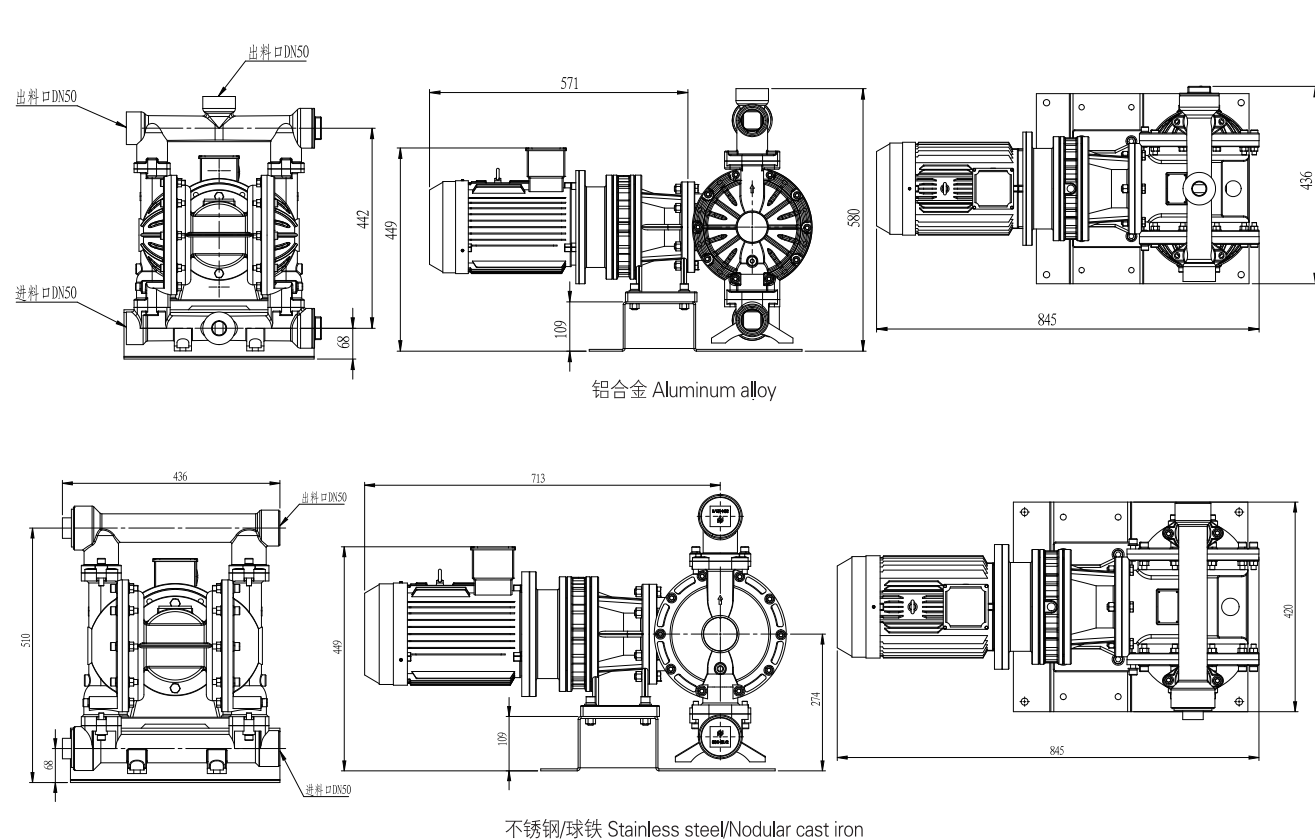

## DBY3-50/65 塑料/氟塑料/衬氟



### 性能曲线图

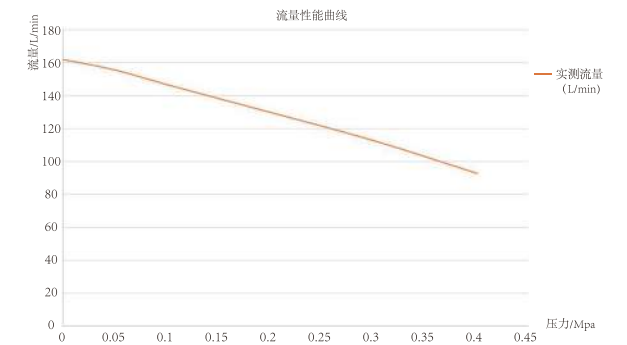

### 规格参数

最大工作流量 Max.Flow	42.8gpm ( 162lpm )	最大输送固体颗粒 Max.Permitted Grain	3/16in.(4.8mm)
最大工作压力 Max.Working Pressure	0.4Mpa / 0.7Mpa	每往复流量 Every Reciprocating Flow	0.5gallon(1.9L)
流体进口尺寸 Fluid Inlet Size	2in.bsp ( f )	最大往复速度 Max.Reciprocating Speed	85cpm
流体出口尺寸 Fluid Outlet Size	2in.bsp ( f )	出口压力 Outlet Pressure	0.4Mpa / 0.7Mpa
最大虹吸高度(干抽或湿抽)		电机功率 Motor power	2.2kw / 3kw
Max.Suction height(dry suction or wet suction)	16.4ft.(5m )		

### 安装尺寸图

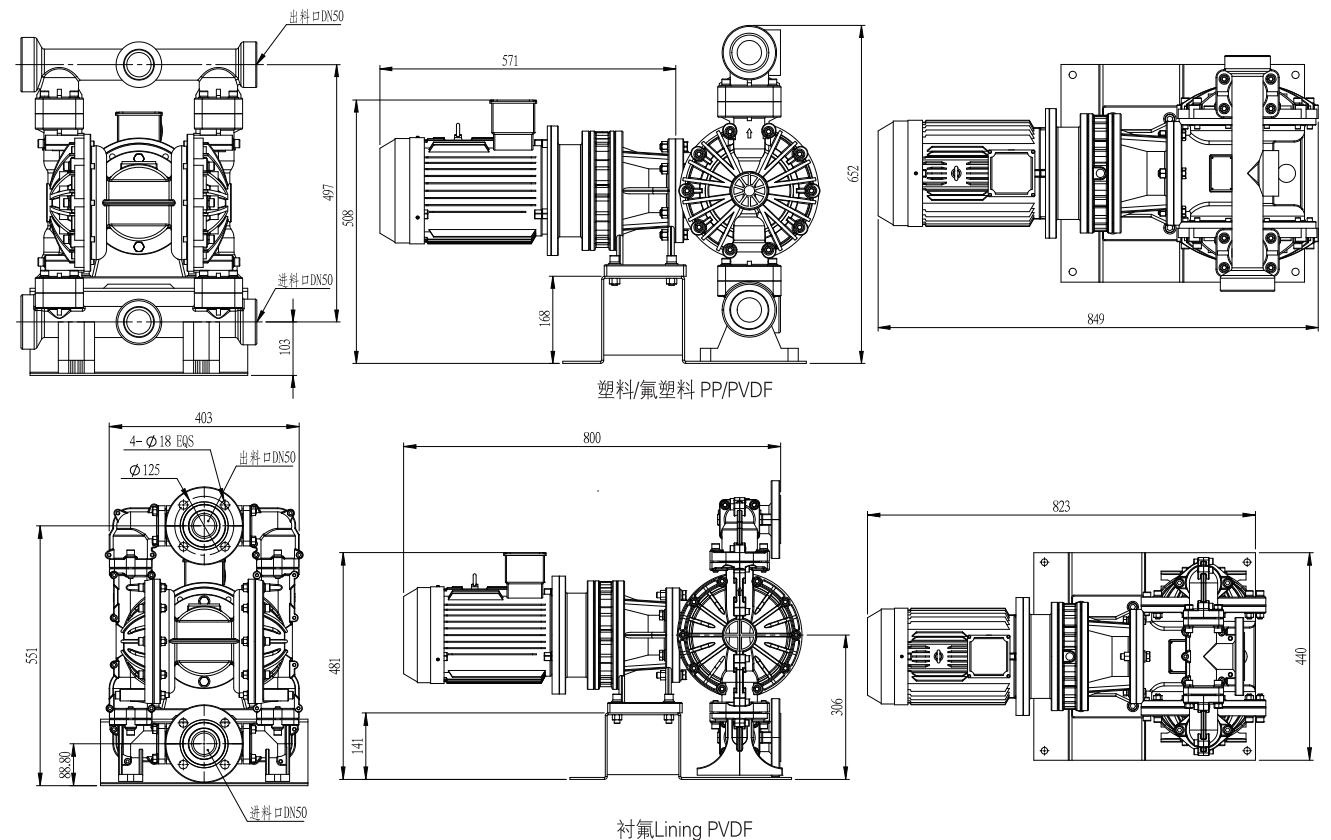

## DBY3-80/100 铝合金/不锈钢/球铁



性能曲线图

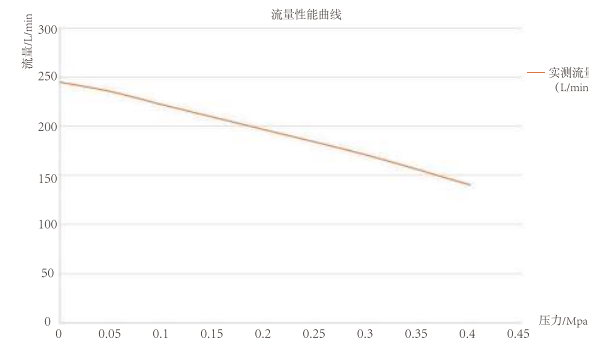

### 规格参数

最大工作流量 Max.Flow	64.7gpm ( 245lpm )	最大输送固体颗粒 Max.Permitted Grain	1/4in.(6.4mm)
最大工作压力 Max.Working Pressure	0.4Mpa / 0.7Mpa	每往复流量 Every Reciprocating Flow	1.03gallon(3.9L)
流体进口尺寸 Fluid Inlet Size	3in.bsp ( f )	最大往复速度 Max.Reciprocating Speed	63cpm
流体出口尺寸 Fluid Outlet Size	3in.bsp ( f )	出口压力 Outlet Pressure	0.4Mpa / 0.7Mpa
最大虹吸高度(干抽或湿抽) Max.Suction height(dry suction or wet suction)	16.4ft.(5m )	电机功率 Motor power	3kw / 4kw

### 安装尺寸图

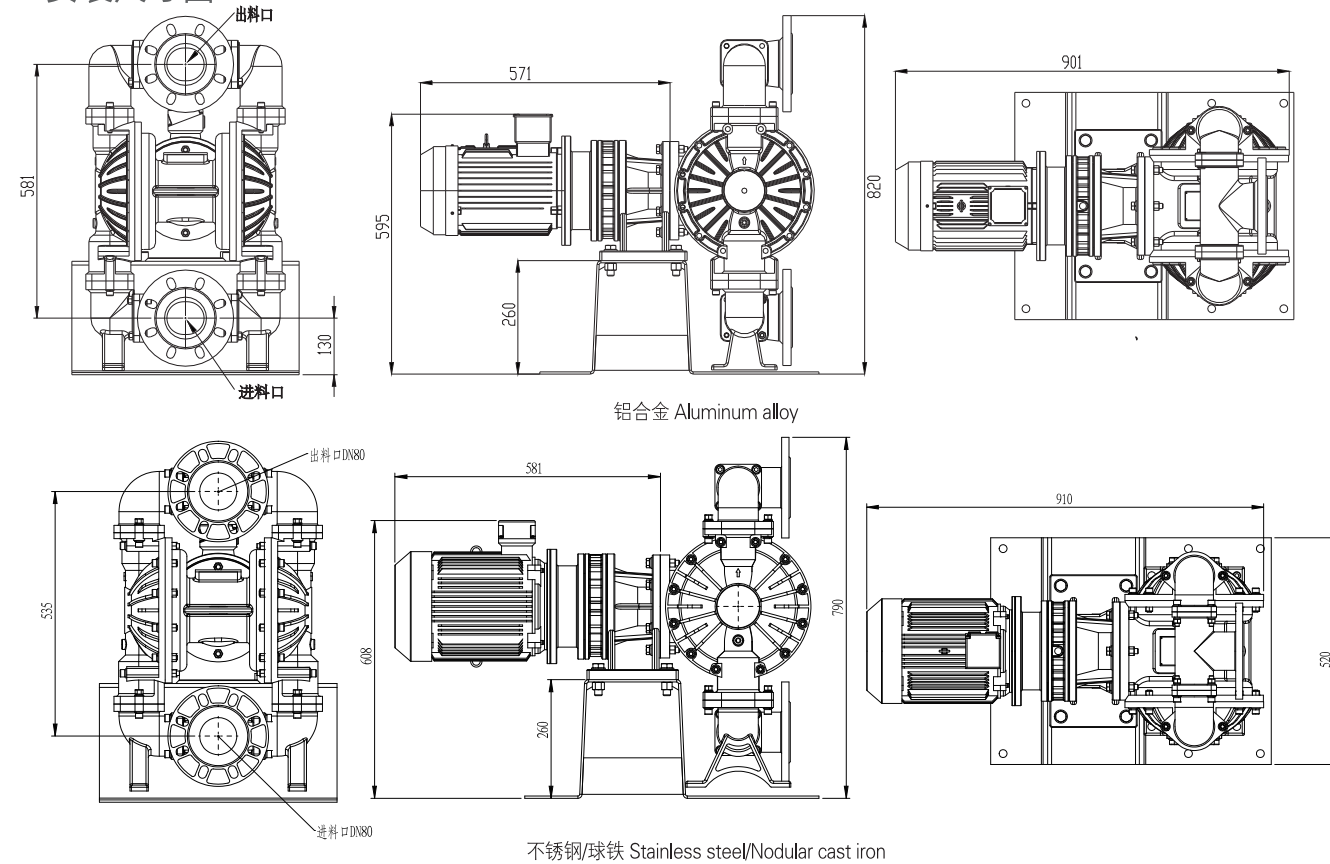

## DBY3-80/100 塑料/氟塑料/衬氟



性能曲线图

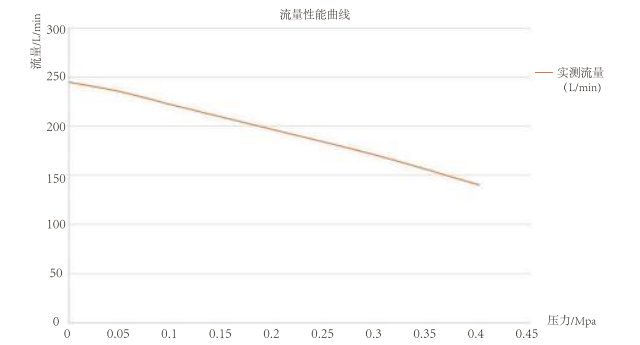

### 规格参数

最大工作流量 Max.Flow	64.7gpm ( 245lpm )	最大输送固体颗粒 Max.Permitted Grain	1/4in.(6.4mm)
最大工作压力 Max.Working Pressure	0.4Mpa / 0.7Mpa	每往复流量 Every Reciprocating Flow	1.03gallon(3.9L)
流体进口尺寸 Fluid Inlet Size	3in.bsp ( f )	最大往复速度 Max.Reciprocating Speed	63cpm
流体出口尺寸 Fluid Outlet Size	3in.bsp ( f )	出口压力 Outlet Pressure	0.4Mpa / 0.7Mpa
最大虹吸高度(干抽或湿抽) Max.Suction height(dry suction or wet suction)	16.4ft.(5m )	电机功率 Motor power	3kw / 4kw

### 安装尺寸图

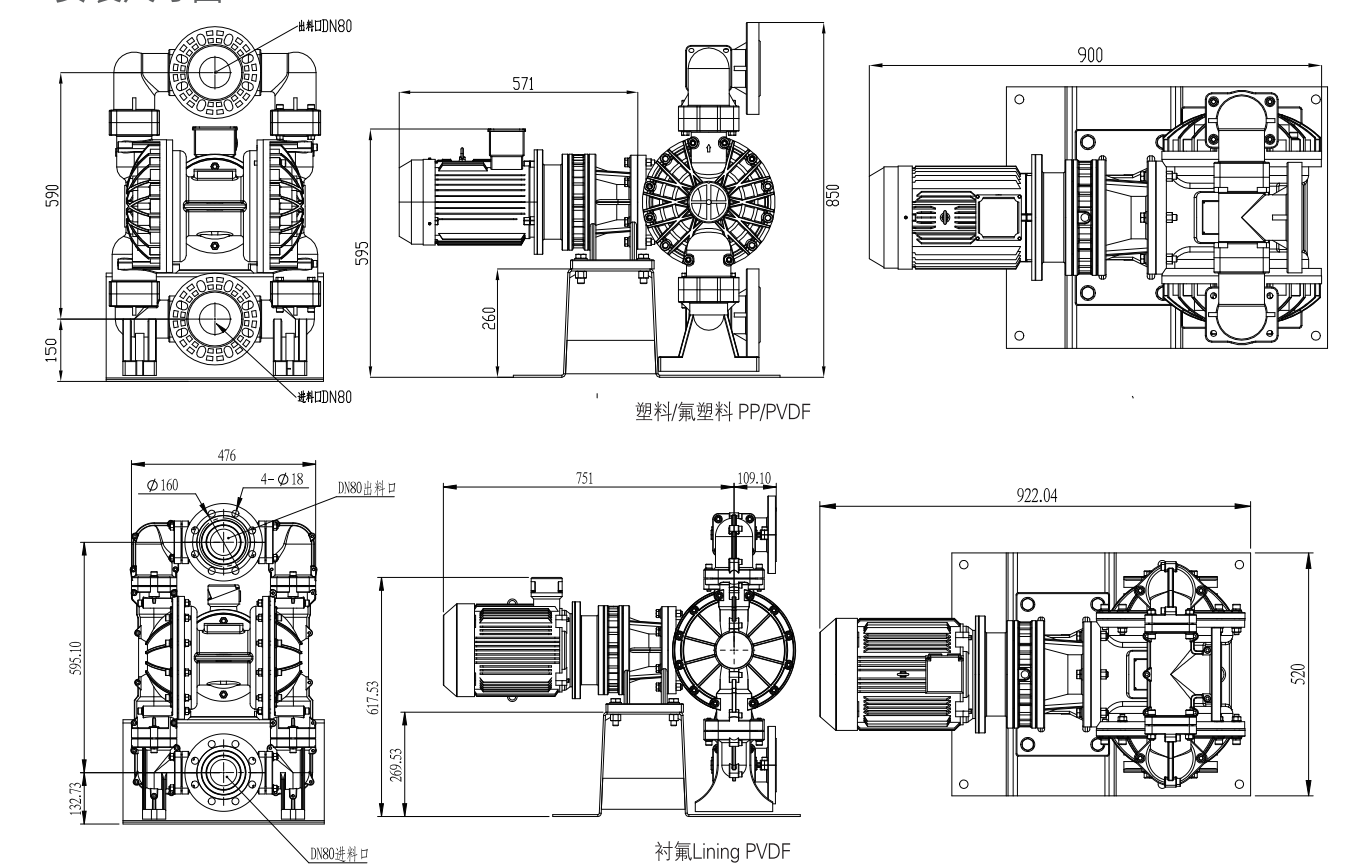

## DBY3-125 铝合金/不锈钢/球铁



### 性能曲线图

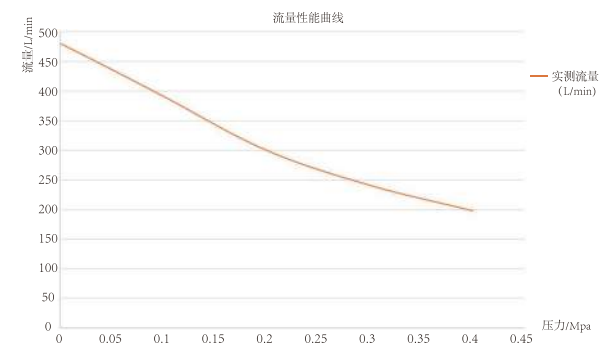

### 规格参数

最大工作流量 Max.Flow	126.8gpm ( 480Lpm )	最大输送固体颗粒 Max.Permitted Grain	3/8in.(9.4mm)
最大工作压力 Max.Working Pressure	0.4Mpa / 0.7Mpa	每往复流量 Every Reciprocating Flow	2.0gallon(7.6L)
流体进口尺寸 Fluid Inlet Size	5in.bsp ( f )	最大往复速度 Max.Reciprocating Speed	63cpm
流体出口尺寸 Fluid Outlet Size	5in.bsp ( f )	出口压力 Outlet Pressure	0.4Mpa / 0.7Mpa
最大虹吸高度(干抽或湿抽) Max.Suction height(dry suction or wet suction)	20ft.(6m )	电机功率 Motor power	4kw / 5.5kw

### 安装尺寸图

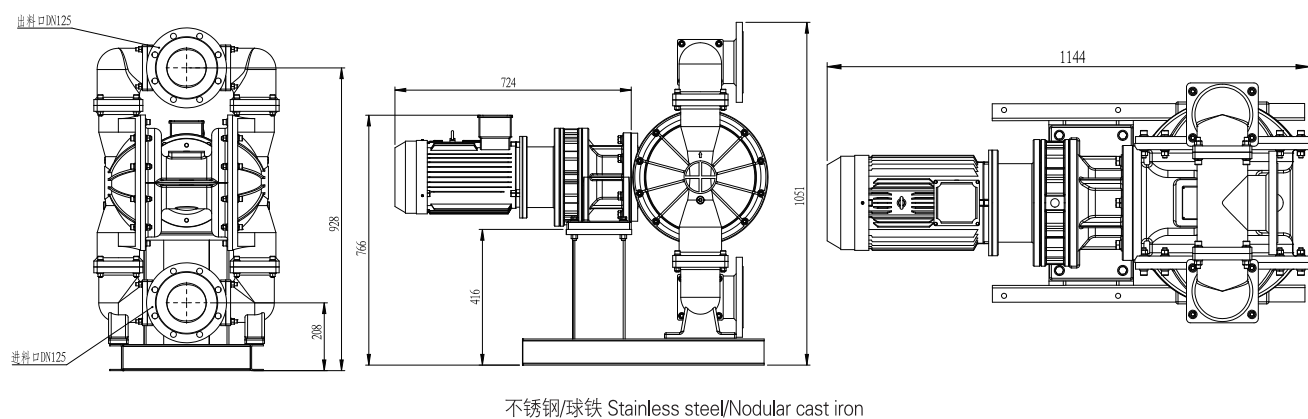
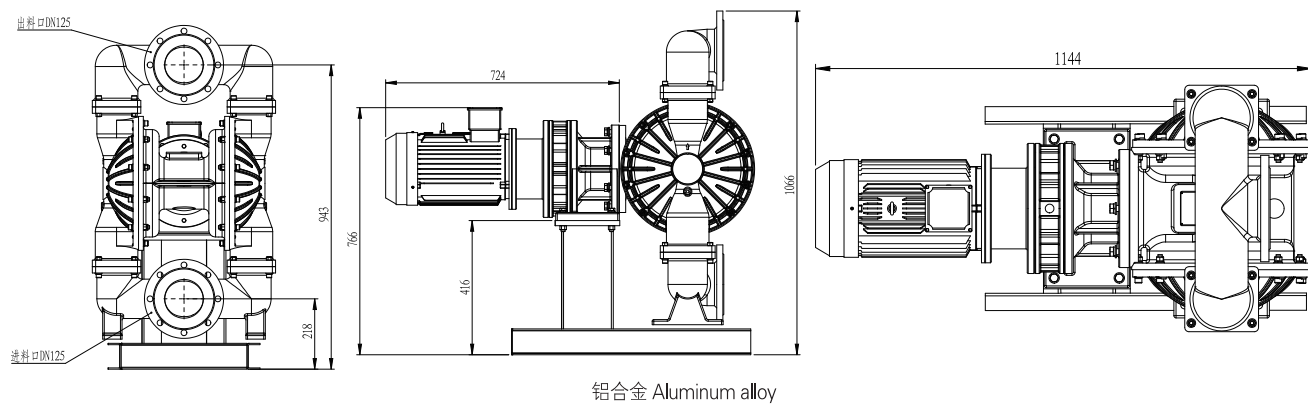

## DBY3-125 塑料/氟塑料/衬氟



### 性能曲线图

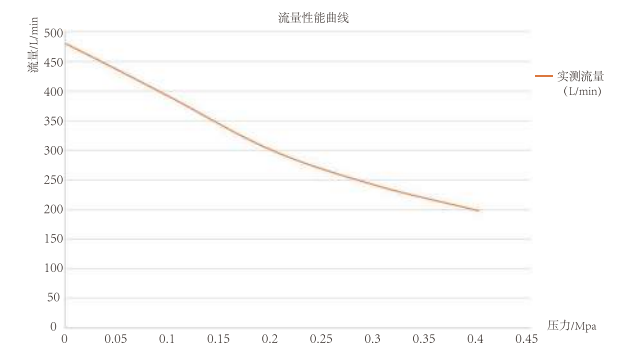

### 规格参数

最大工作流量 Max.Flow	126.8gpm ( 480Lpm )	最大输送固体颗粒 Max.Permitted Grain	3/8in.(9.4mm)
最大工作压力 Max.Working Pressure	0.4Mpa / 0.7Mpa	每往复流量 Every Reciprocating Flow	2.0gallon(7.6L)
流体进口尺寸 Fluid Inlet Size	5in.bsp ( f )	最大往复速度 Max.Reciprocating Speed	63cpm
流体出口尺寸 Fluid Outlet Size	5in.bsp ( f )	出口压力 Outlet Pressure	0.4Mpa / 0.7Mpa
最大虹吸高度(干抽或湿抽) Max.Suction height(dry suction or wet suction)	20ft.(6m )	电机功率 Motor power	4kw / 5.5kw

### 安装尺寸图

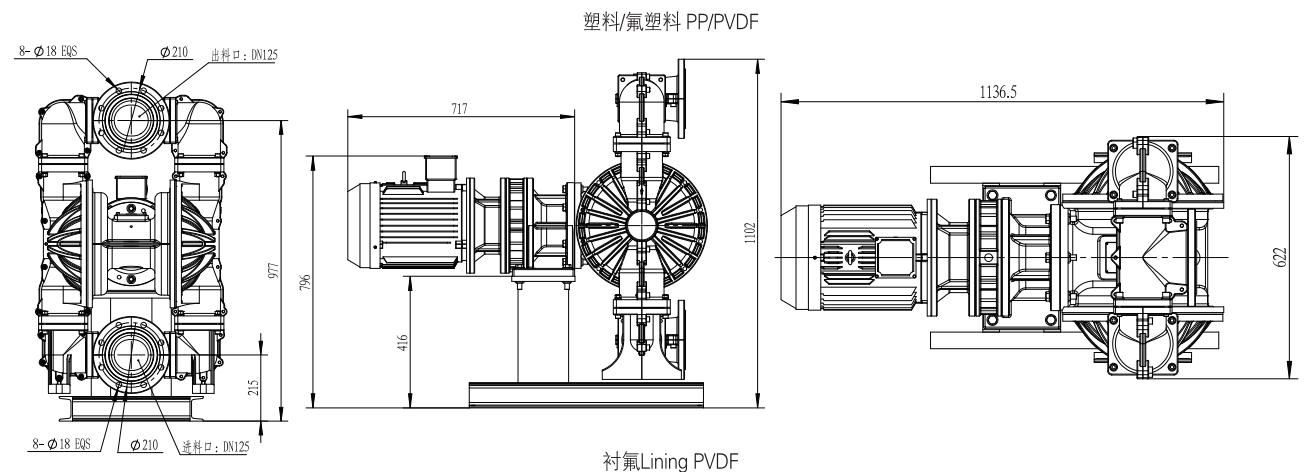
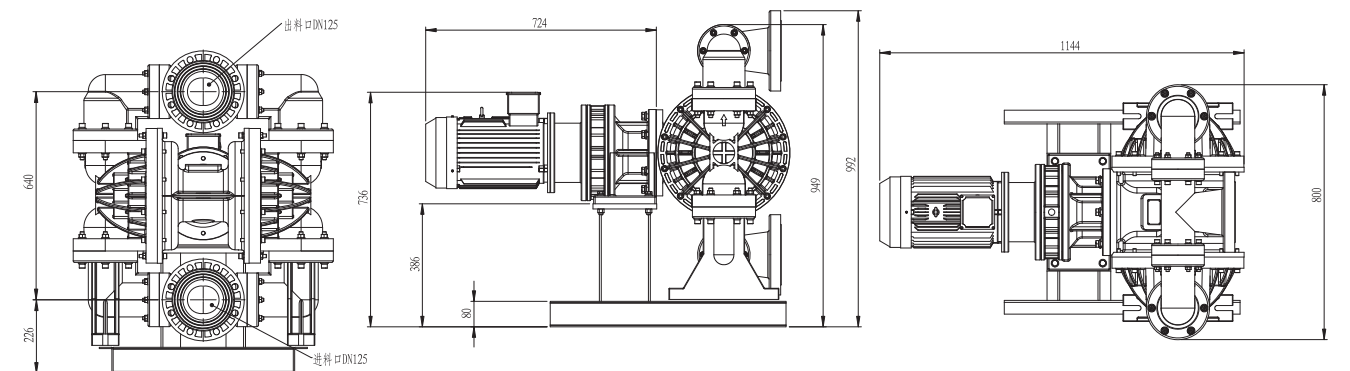

# 07

**Q/DBW3**  
卫生泵



## QBW3-25 不锈钢304

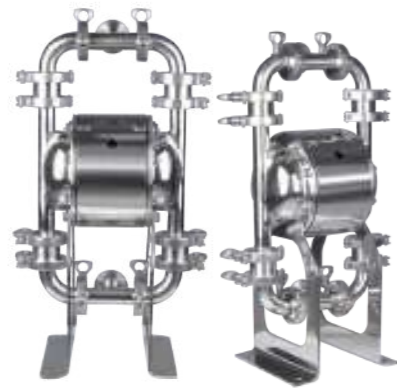

### 性能曲线图

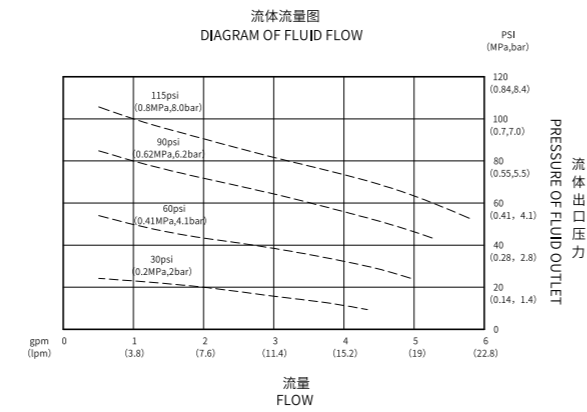

### 规格参数

最大工作流量 Max. Flow	15 gpm (57 lpm)
最大工作压力 Max. Working Pressure	100 psi (0.7 Mpa, 7bar)
流体进口尺寸 Fluid Inlet Size	3/4 in. bsp (f) / 1 in. bsp (f)
流体出口尺寸 Fluid Outlet Size	3/4 in. bsp (f) / 1 in. bsp (f)
空气进口尺寸 Air Inlet Size	1/4 in. bsp (f)

最大虹吸高度 (干抽或湿抽) Max.Suction Height (dry suction or wet suction)	15 ft. (4.5 m)
最大输送固体颗粒 Max. Permitted Grain	3/32 in. (2.5 mm)
每往复流量 Every Reciprocating Flow	0.04 gal. (0.15 L)
最大往复速度 Max. Reciprocating Speed	400 cpm

### 安装尺寸图

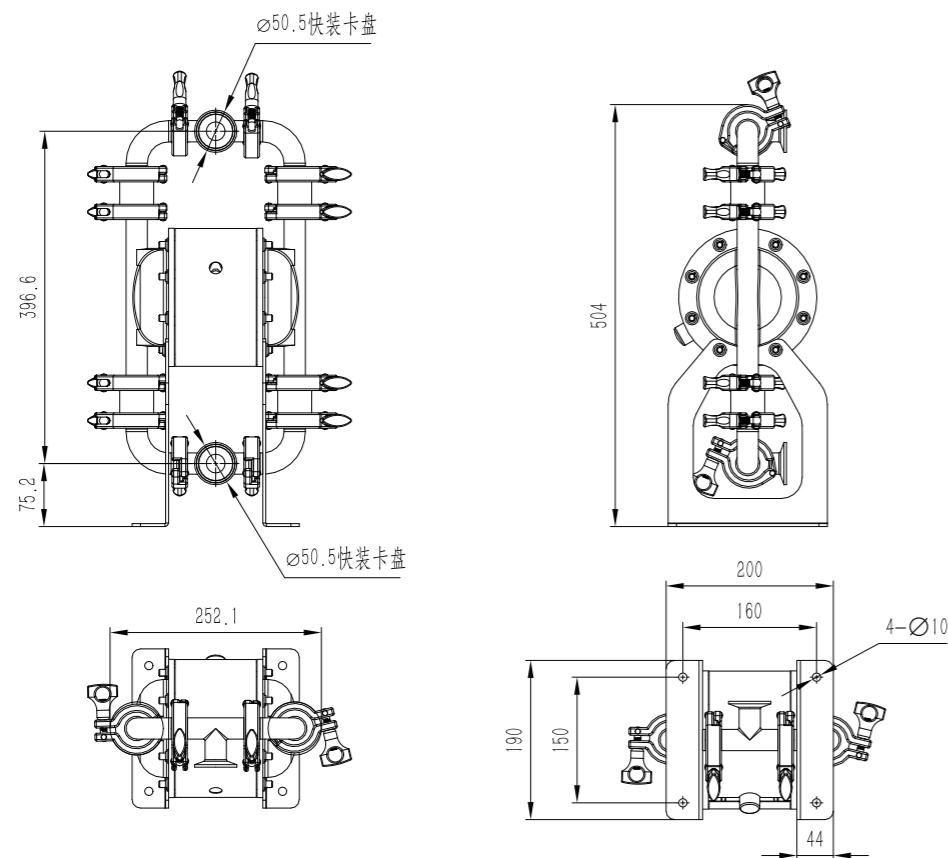

## QBW3-40 不锈钢304

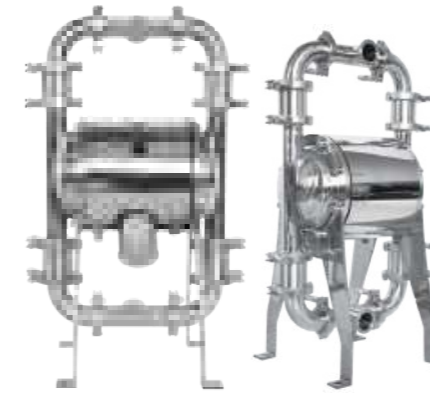

### 性能曲线图

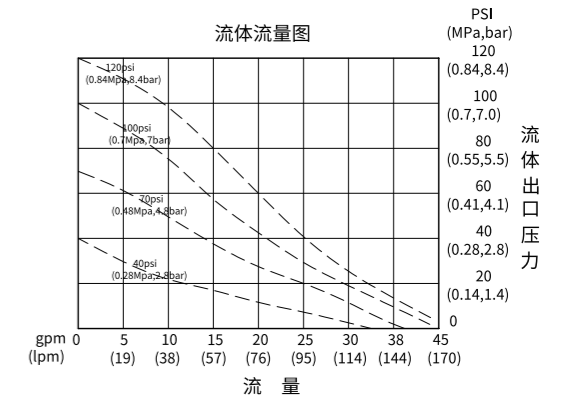

### 规格参数

最大工作流量 Max. Flow	45 gpm (170 lpm)
最大工作压力 Max. Working Pressure	120 psi (0.84 Mpa, 8.4 bar)
流体进口尺寸 Fluid Inlet Size	1-1/4 in. bsp (f) / 1-1/2 in. bsp (f)
流体出口尺寸 Fluid Outlet Size	1-1/4 in. bsp (f) / 1-1/2 in. bsp (f)
空气进口尺寸 Air Inlet Size	1/2 in. bsp (f)

最大虹吸高度 (干抽或湿抽) Max.Suction Height (dry suction or wet suction)	18 ft. (5.48 m)
最大输送固体颗粒 Max. Permitted Grain	1/8 in. (3.2 mm)
每往复流量 Every Reciprocating Flow	0.15 gal. (0.57 L)
最大往复速度 Max. Reciprocating Speed	276 cpm

### 安装尺寸图

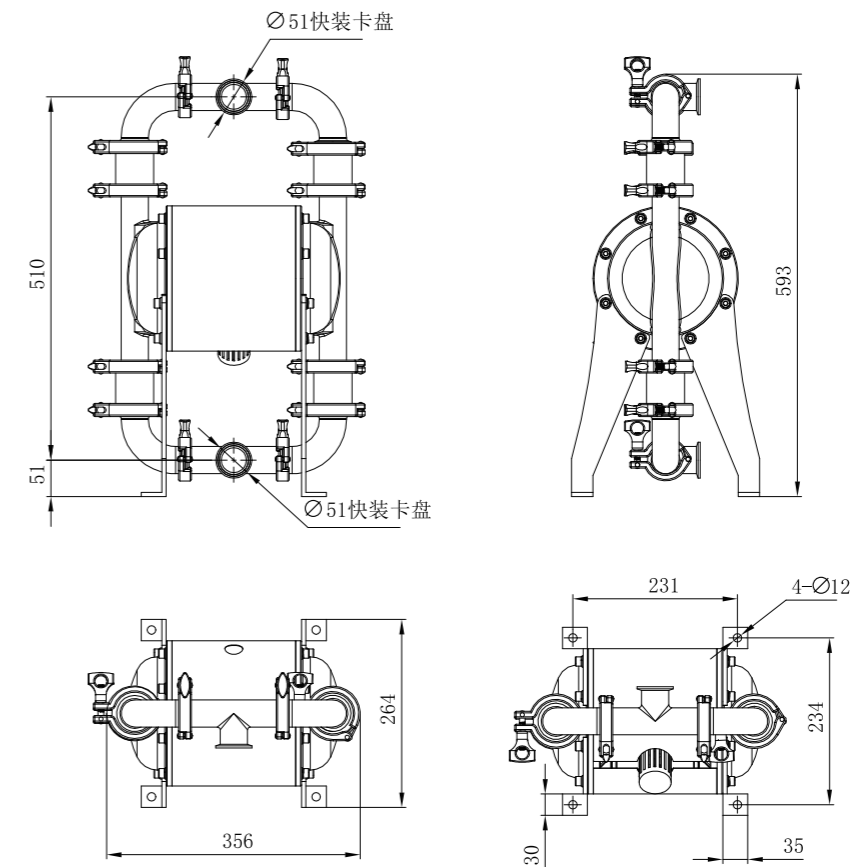

## QBW3-50 不锈钢304



### 性能曲线图

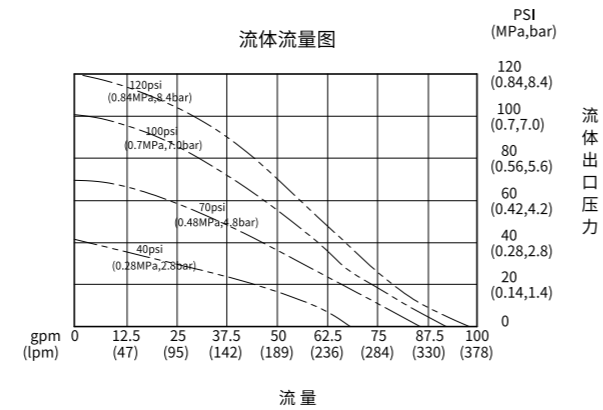

### 规格参数

最大工作流量 Max. Flow	100 gpm (378.5 lpm)
最大工作压力 Max. Working Pressure	120 psi (0.84 Mpa, 8.4 bar)
流体进口尺寸 Fluid Inlet Size	2 in. bsp (f) / 2-1/2 in. bsp (f)
流体出口尺寸 Fluid Outlet Size	2 in. bsp (f) / 2-1/2 in. bsp (f)
空气进口尺寸 Air Inlet Size	1/2 in. bsp (f)

最大虹吸高度 (干抽或湿抽) Max.Suction Height (dry suction or wet suction)	18 ft. (5.48 m)
最大输送固体颗粒 Max. Permitted Grain	3/16 in. (4.8 mm)
每往复流量 Every Reciprocating Flow	0.5 gal. (1.9 L)
最大往复速度 Max. Reciprocating Speed	200 cpm

### 安装尺寸图

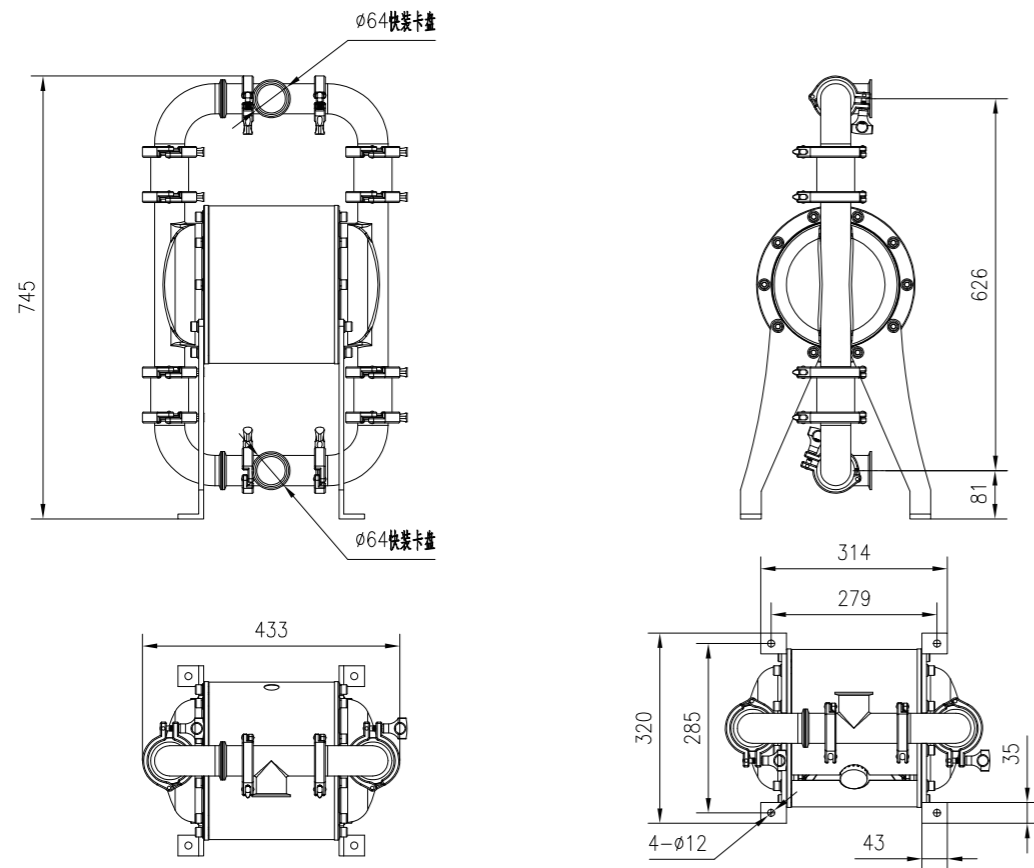

## QBW3-80 不锈钢304

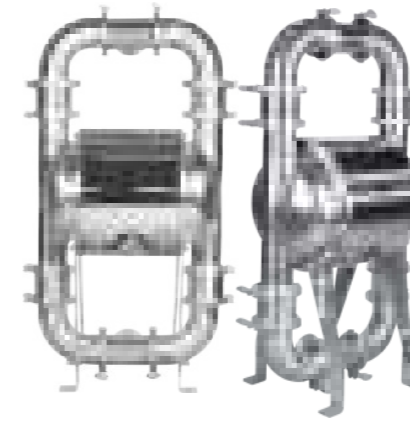

### 性能曲线图

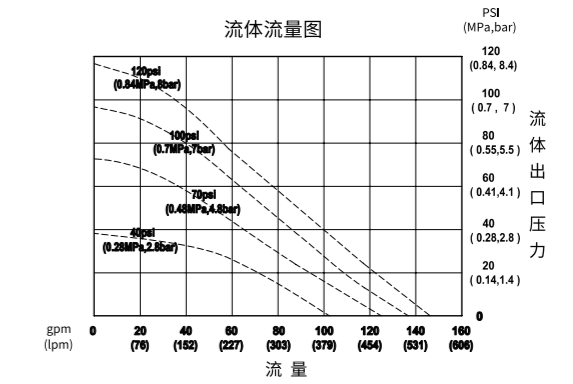

### 规格参数

最大工作流量 Max. Flow	150 gpm (568 lpm)
最大工作压力 Max. Working Pressure	120 psi (0.84 Mpa, 8.4 bar)
流体进口尺寸 Fluid Inlet Size	3 in. bsp (f) / 4 in. bsp (f)
流体出口尺寸 Fluid Outlet Size	3 in. bsp (f) / 4 in. bsp (f)
空气进口尺寸 Air Inlet Size	1/2 in. bsp (f)

最大虹吸高度 (干抽或湿抽) Max.Suction Height (dry suction or wet suction)	18 ft. (5.48 m)
最大输送固体颗粒 Max. Permitted Grain	1/4 in. (6.4 mm)
每往复流量 Every Reciprocating Flow	1.03 gal. (3.90 L)
最大往复速度 Max. Reciprocating Speed	145 cpm

### 安装尺寸图

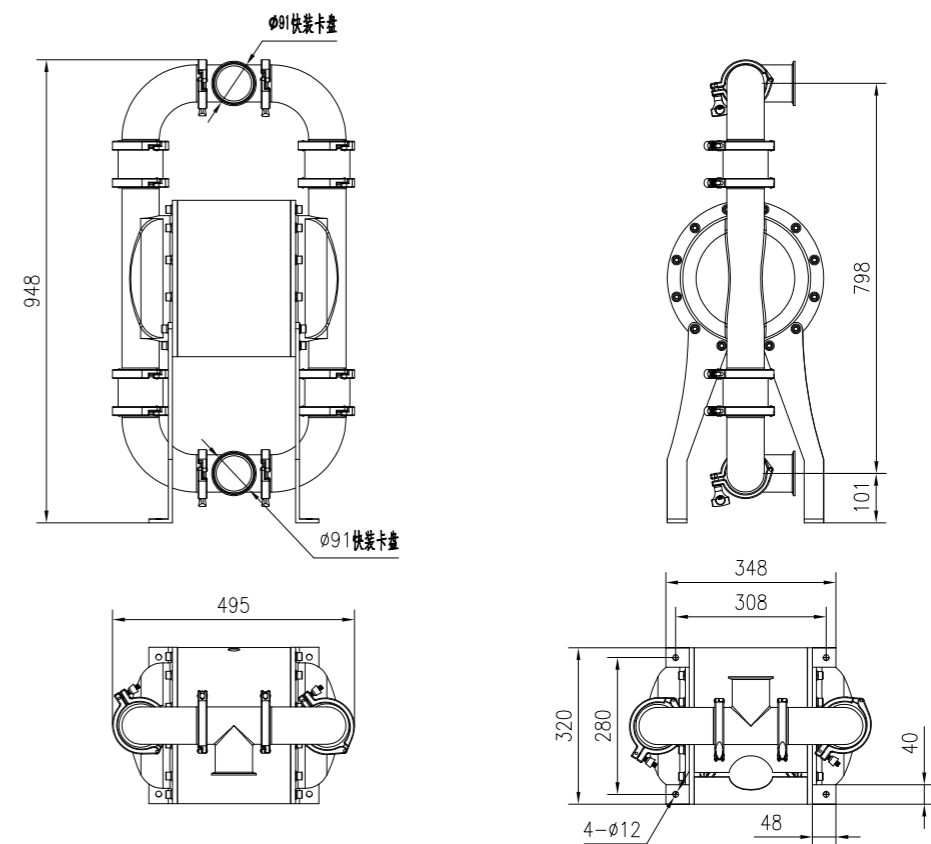

## DBW3-25 不锈钢304

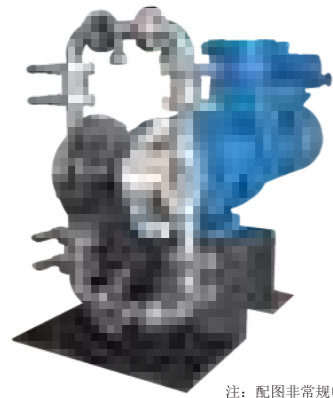

注：配图非常规电机

### 性能曲线图

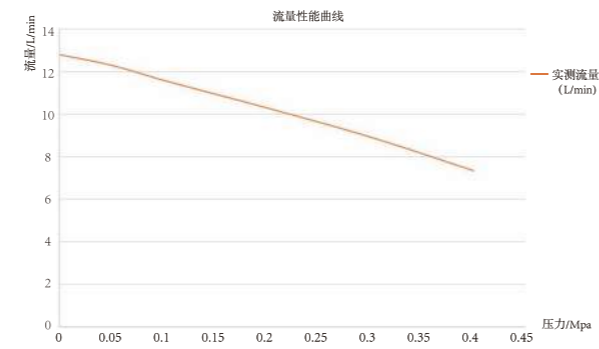

### 规格参数

最大工作流量 Max.Flow	3.4gpm ( 12.8Lpm )	最大输送固体颗粒 Max.Permitted Grain	3/32in.(2.5mm)
最大工作压力 Max.Working Pressure	0.4Mpa / 0.7Mpa	每往复流量 Every Reciprocating Flow	0.04gallon(0.15L)
流体进口尺寸 Fluid Inlet Size	3/4in.bsp ( f )	最大往复速度 Max.Reciprocating Speed	85cpm
流体出口尺寸 Fluid Outlet Size	3/4in.bsp ( f )	出口压力 Outlet Pressure	0.4Mpa / 0.7Mpa
最大虹吸高度(干抽或湿抽)		电机功率 Motor power	0.55kw / 0.75kw
Max.Suction height(dry suction or wet suction)	10ft.(3m )		

### 安装尺寸图

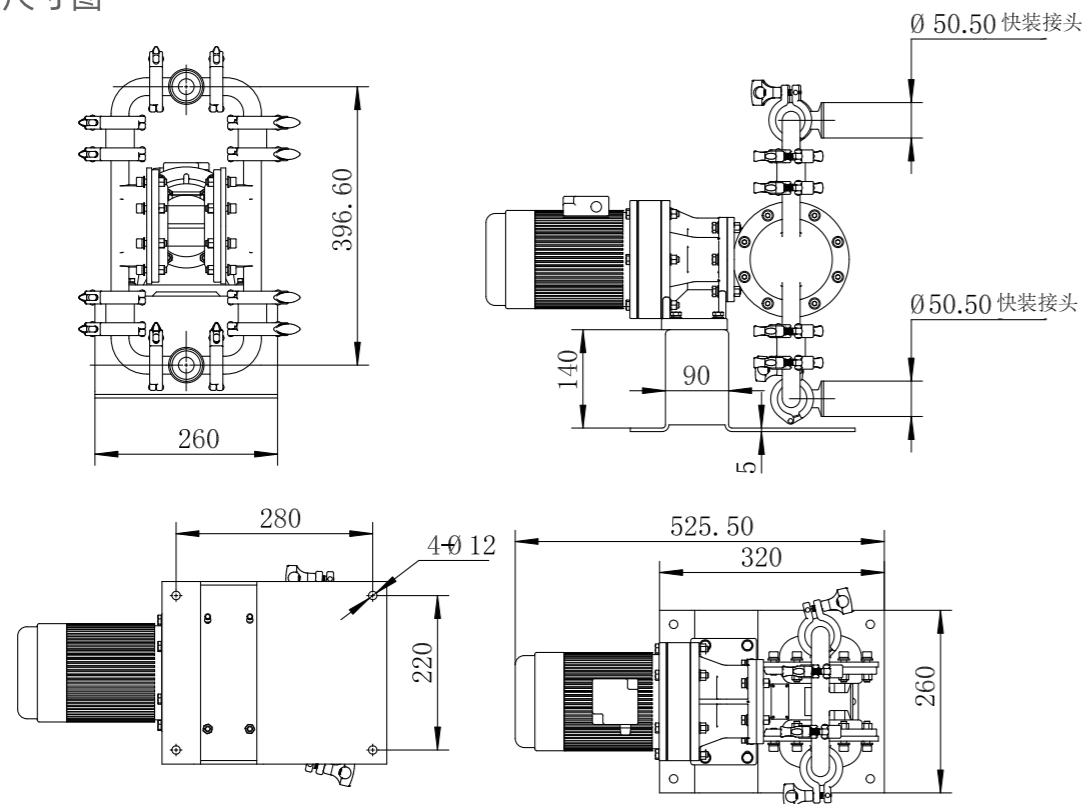

## DBW3-40 不锈钢304



### 性能曲线图

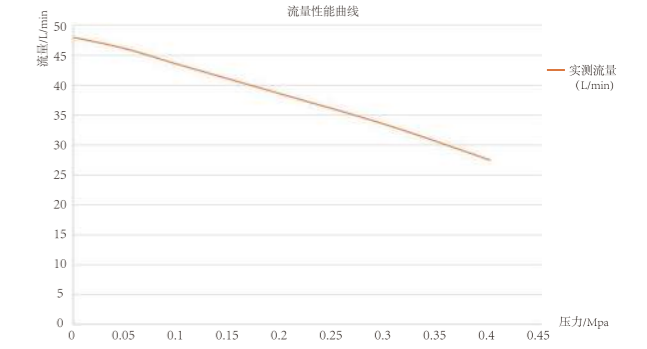

### 规格参数

最大工作流量 Max.Flow	12.7gpm ( 48Lpm )	最大输送固体颗粒 Max.Permitted Grain	1/8in.(3.2mm)
最大工作压力 Max.Working Pressure	0.4Mpa / 0.7Mpa	每往复流量 Every Reciprocating Flow	0.15gallon(0.57L)
流体进口尺寸 Fluid Inlet Size	1-1/2in.bsp ( f )	最大往复速度 Max.Reciprocating Speed	85cpm
流体出口尺寸 Fluid Outlet Size	1-1/2in.bsp ( f )	出口压力 Outlet Pressure	0.4Mpa / 0.7Mpa
最大虹吸高度(干抽或湿抽)		电机功率 Motor power	1.5kw / 2.2kw
Max.Suction height(dry suction or wet suction)	13ft.(4m )		

### 安装尺寸图

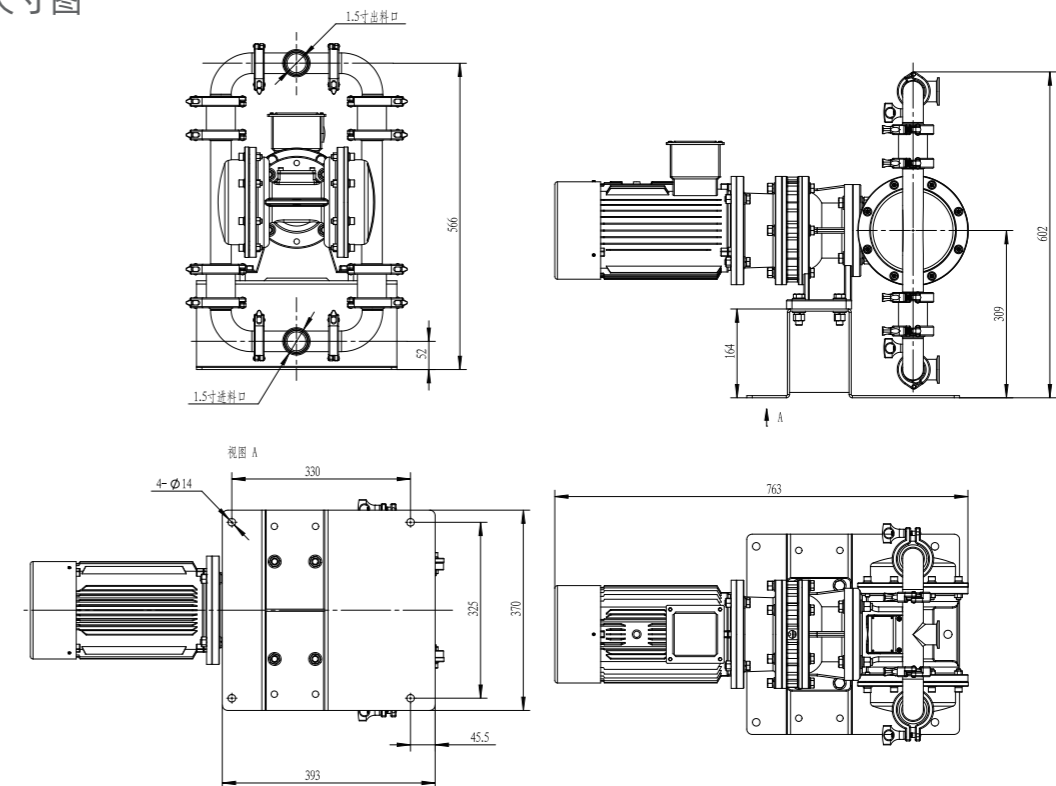

## DBW3-50 不锈钢304



### 性能曲线图

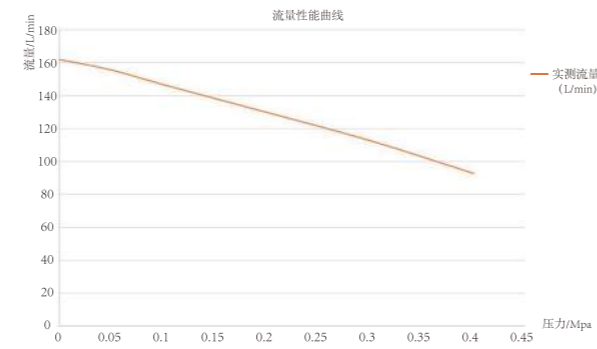

### 规格参数

最大工作流量 Max.Flow	42.8gpm ( 162lpm )	最大输送固体颗粒 Max.Permitted Grain	3/16in.(4.8mm)
最大工作压力 Max.Working Pressure	0.4Mpa / 0.7Mpa	每往复流量 Every Reciprocating Flow	0.5gallon(1.9L)
流体进口尺寸 Fluid Inlet Size	2in.bsp ( f )	最大往复速度 Max.Reciprocating Speed	85cpm
流体出口尺寸 Fluid Outlet Size	2in.bsp ( f )	出口压力 Outlet Pressure	0.4Mpa / 0.7Mpa
最大虹吸高度(干抽或湿抽)		电机功率 Motor power	2.2kw / 3kw
Max.Suction height(dry suction or wet suction)	16.4ft.(5m )		

### 安装尺寸图

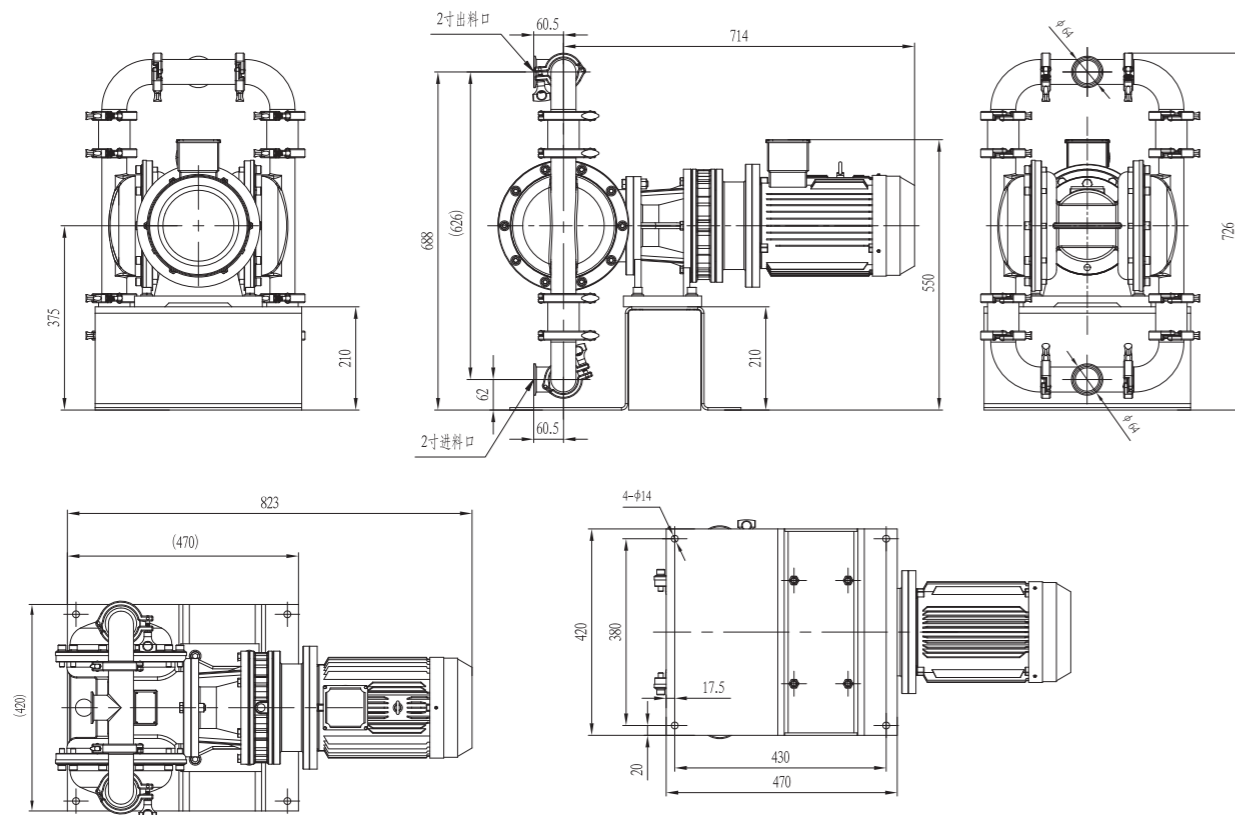

## DBW3-80 不锈钢304



### 性能曲线图

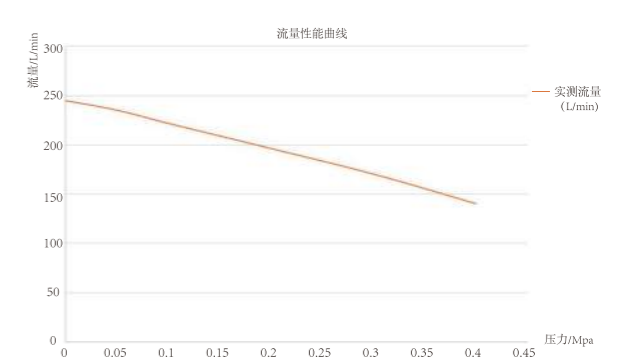

### 规格参数

最大工作流量 Max.Flow	64.7gpm ( 245lpm )	最大输送固体颗粒 Max.Permitted Grain	1/4in.(6.4mm)
最大工作压力 Max.Working Pressure	0.4Mpa / 0.7Mpa	每往复流量 Every Reciprocating Flow	1.03gallon(3.9L)
流体进口尺寸 Fluid Inlet Size	3in.bsp ( f )	最大往复速度 Max.Reciprocating Speed	63cpm
流体出口尺寸 Fluid Outlet Size	3in.bsp ( f )	出口压力 Outlet Pressure	0.4Mpa / 0.7Mpa
最大虹吸高度(干抽或湿抽)		电机功率 Motor power	3kw / 4kw
Max.Suction height(dry suction or wet suction)	16.4ft.(5m )		

### 安装尺寸图

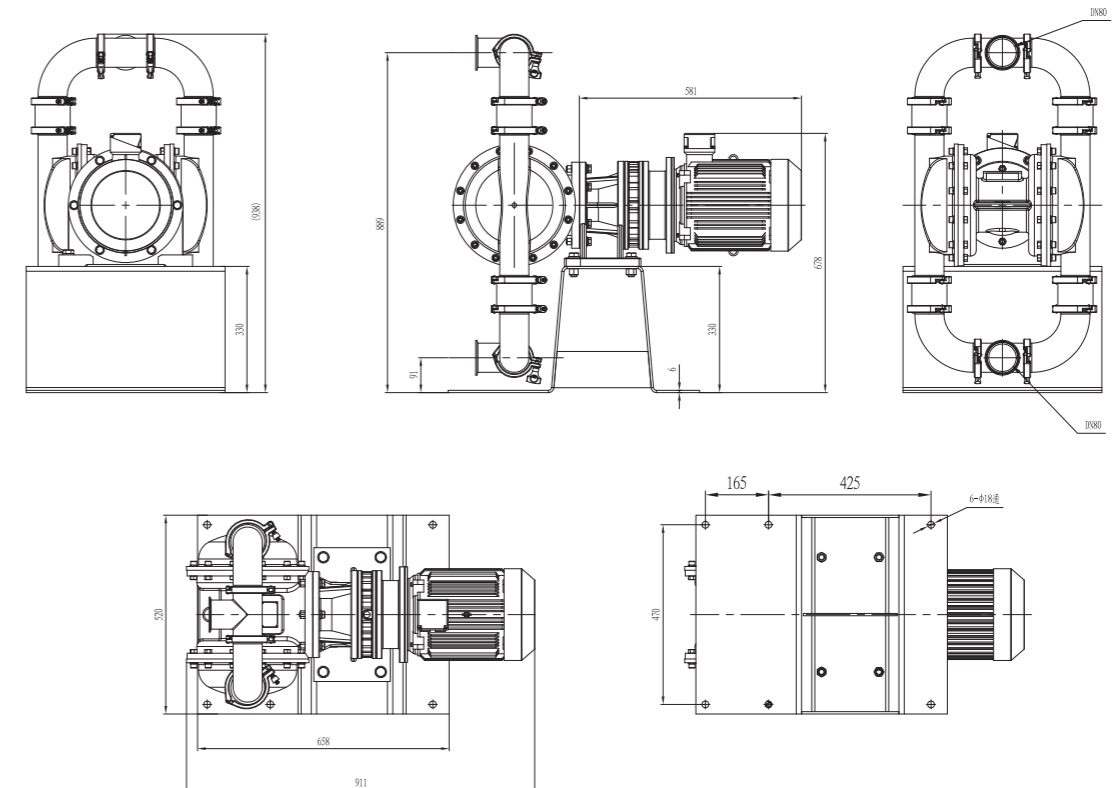

## DBW3-25 不锈钢304

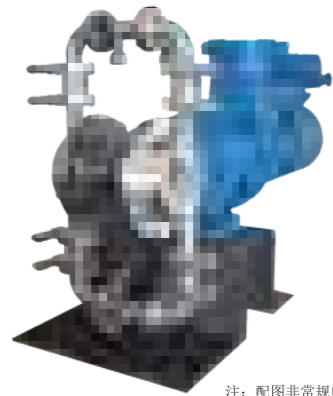

注：配图非常规电机

### 性能曲线图

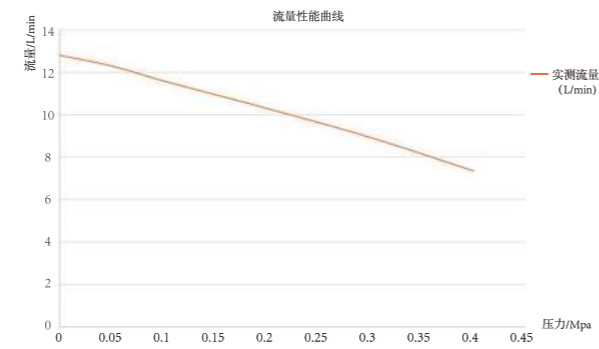

### 规格参数

最大工作流量 Max.Flow	3.4gpm ( 12.8Lpm )	最大输送固体颗粒 Max.Permitted Grain	3/32in.(2.5mm)
最大工作压力 Max.Working Pressure	0.4Mpa / 0.7Mpa	每往复流量 Every Reciprocating Flow	0.04gallon(0.15L)
流体进口尺寸 Fluid Inlet Size	1/2in.bsp ( f )	最大往复速度 Max.Reciprocating Speed	85cpm
流体出口尺寸 Fluid Outlet Size	1/2in.bsp ( f )	出口压力 Outlet Pressure	0.4Mpa / 0.7Mpa
最大虹吸高度(干抽或湿抽)		电机功率 Motor power	0.55kw / 0.75kw
Max.Suction height(dry suction or wet suction)	10ft.(3m )		

### 安装尺寸图

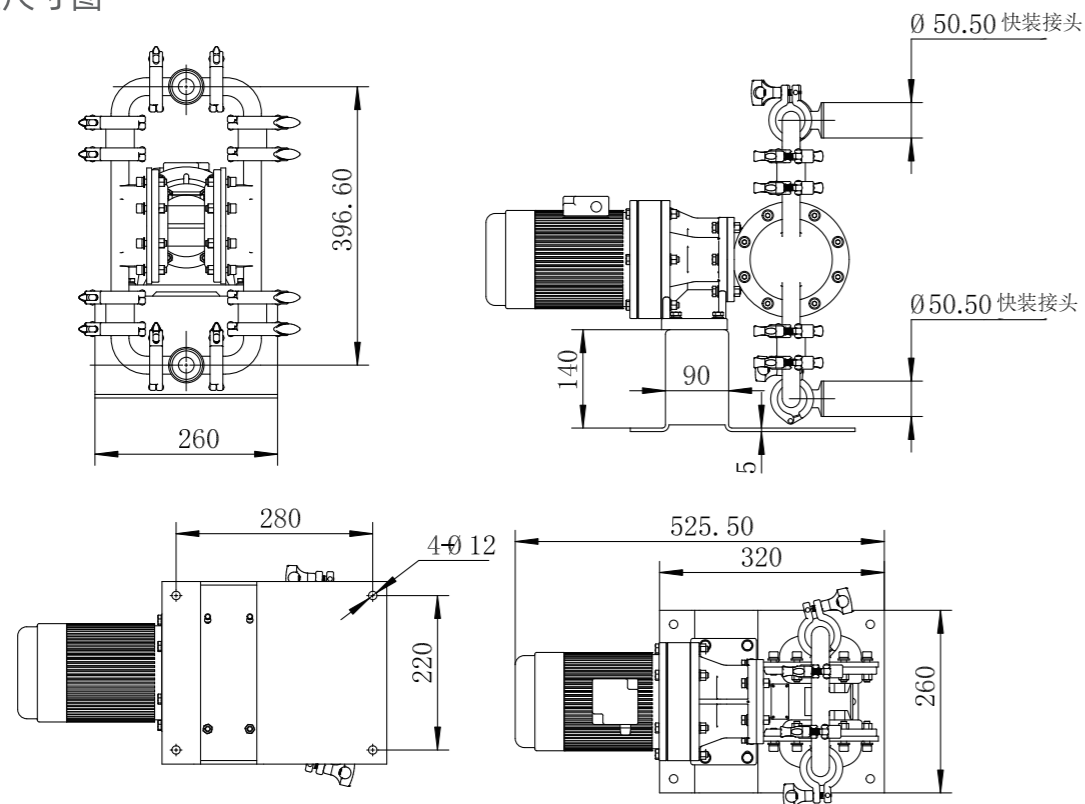

## DBW3-40 不锈钢304



### 性能曲线图

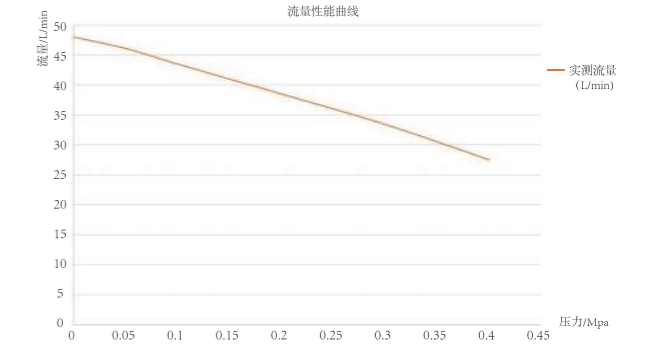

### 规格参数

最大工作流量 Max.Flow	12.7gpm ( 48Lpm )	最大输送固体颗粒 Max.Permitted Grain	1/8in.(3.2mm)
最大工作压力 Max.Working Pressure	0.4Mpa / 0.7Mpa	每往复流量 Every Reciprocating Flow	0.15gallon(0.57L)
流体进口尺寸 Fluid Inlet Size	1-1/2in.bsp ( f )	最大往复速度 Max.Reciprocating Speed	85cpm
流体出口尺寸 Fluid Outlet Size	1-1/2in.bsp ( f )	出口压力 Outlet Pressure	0.4Mpa / 0.7Mpa
最大虹吸高度(干抽或湿抽)		电机功率 Motor power	1.5kw / 2.2kw
Max.Suction height(dry suction or wet suction)	13ft.(4m )		

### 安装尺寸图

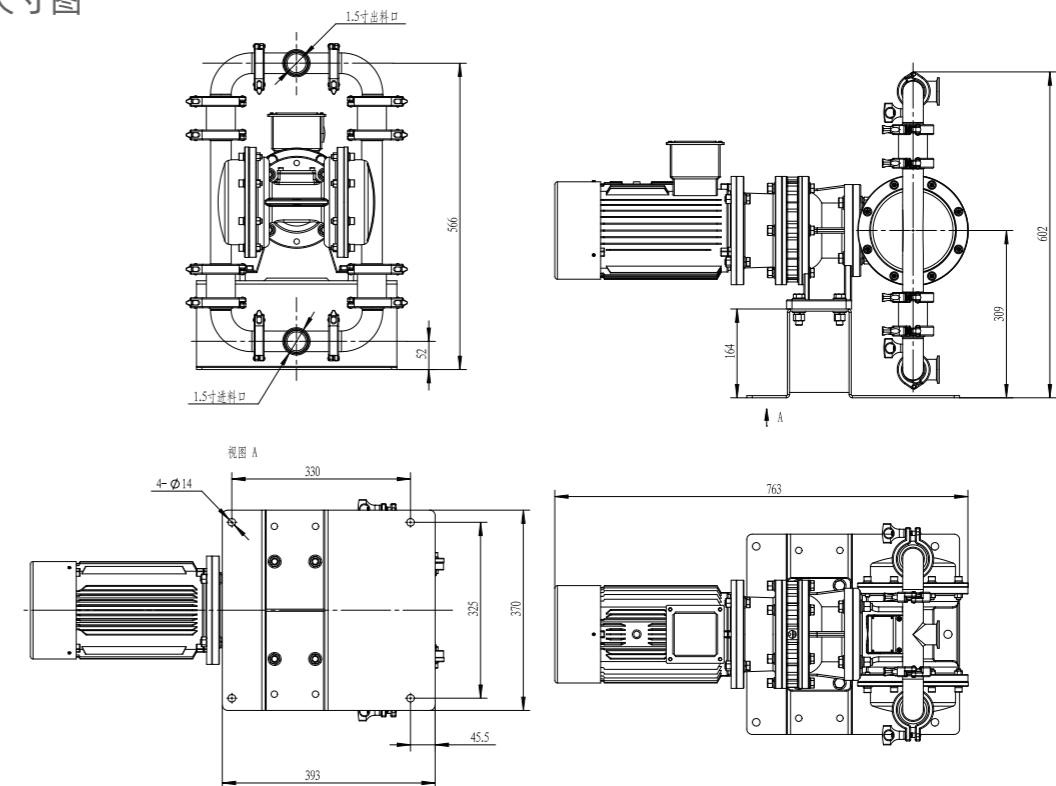

## DBW3-50 不锈钢304



### 性能曲线图

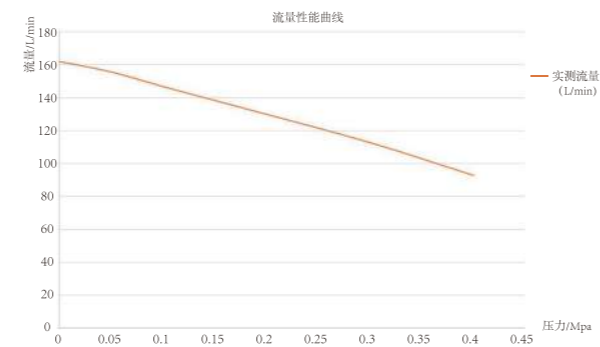

### 规格参数

最大工作流量 Max.Flow	42.8gpm ( 162lpm )	最大输送固体颗粒 Max.Permitted Grain	3/16in.(4.8mm)
最大工作压力 Max.Working Pressure	0.4Mpa / 0.7Mpa	每往复流量 Every Reciprocating Flow	0.5gallon(1.9L)
流体进口尺寸 Fluid Inlet Size	1-1/2in.bsp ( f )	最大往复速度 Max.Reciprocating Speed	85cpm
流体出口尺寸 Fluid Outlet Size	1-1/2in.bsp ( f )	出口压力 Outlet Pressure	0.4Mpa / 0.7Mpa
最大虹吸高度(干抽或湿抽)		电机功率 Motor power	2.2kw / 3kw
Max.Suction height(dry suction or wet suction)	16.4ft.(5m )		

### 安装尺寸图

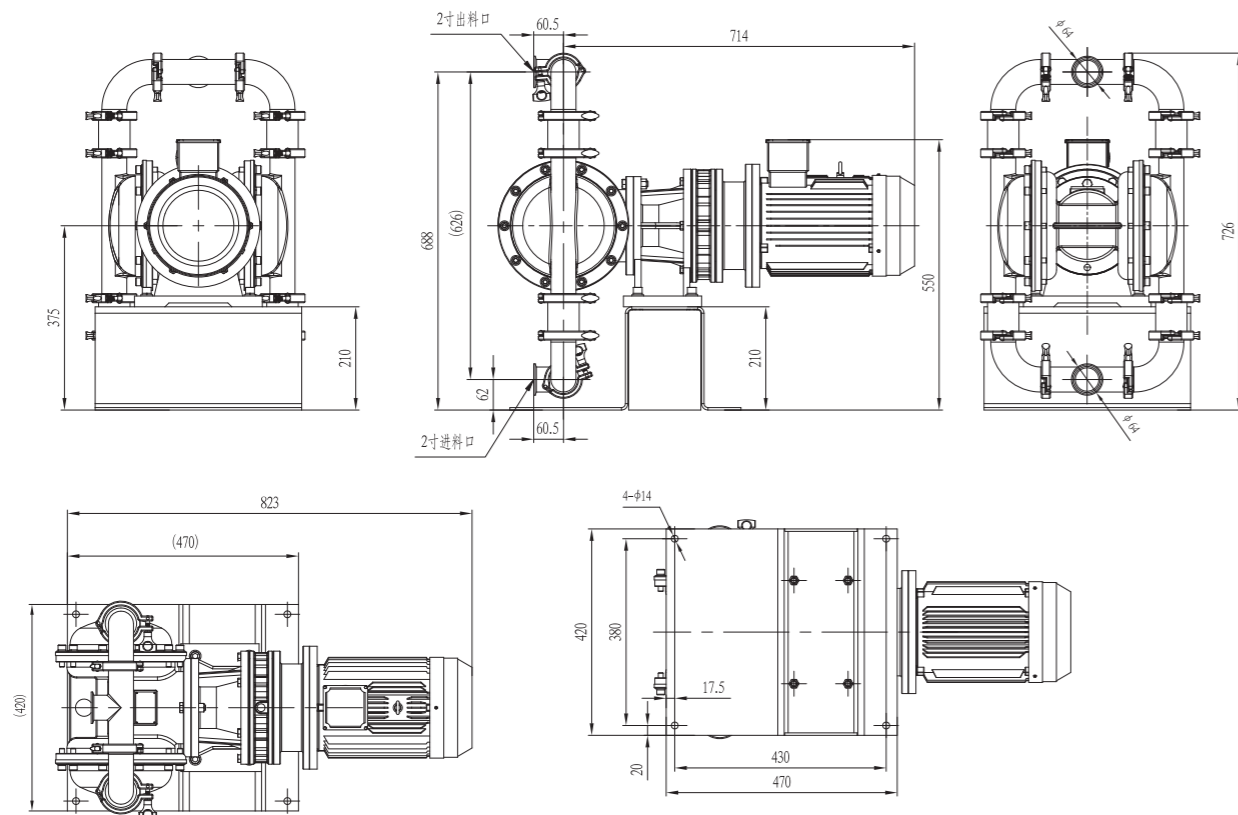

## DBW3-80 不锈钢304



### 性能曲线图

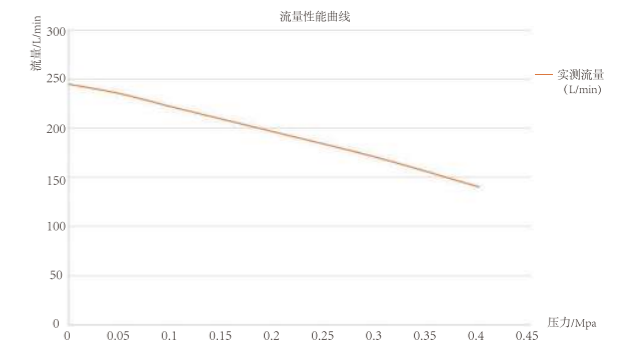

### 规格参数

最大工作流量 Max.Flow	64.7gpm ( 245lpm )	最大输送固体颗粒 Max.Permitted Grain	1/4in.(6.4mm)
最大工作压力 Max.Working Pressure	0.4Mpa / 0.7Mpa	每往复流量 Every Reciprocating Flow	1.03gallon(3.9L)
流体进口尺寸 Fluid Inlet Size	3in.bsp ( f )	最大往复速度 Max.Reciprocating Speed	63cpm
流体出口尺寸 Fluid Outlet Size	3in.bsp ( f )	出口压力 Outlet Pressure	0.4Mpa / 0.7Mpa
最大虹吸高度(干抽或湿抽)		电机功率 Motor power	3kw / 4kw
Max.Suction height(dry suction or wet suction)	16.4ft.(5m )		

### 安装尺寸图

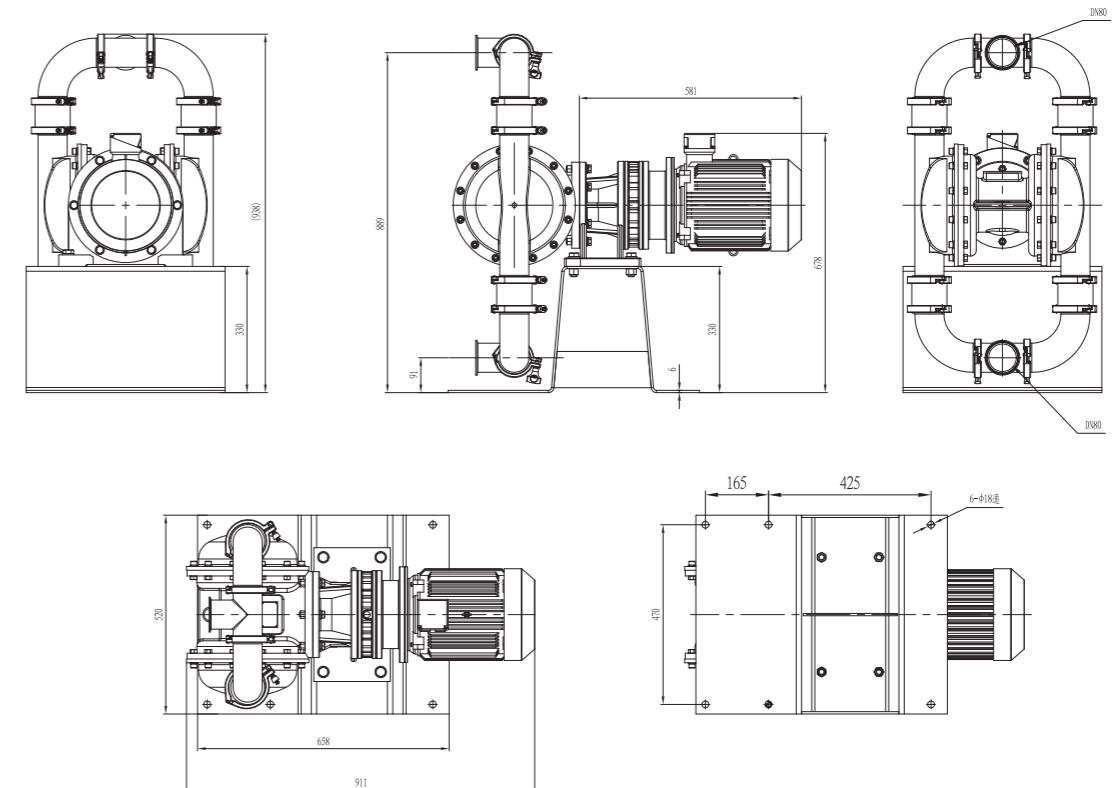

# 08

周边产品及配件



## 适配附件/配件展示

脉冲阻尼器  
Pulse Damper



泵配件  
Pump accessories



法兰  
Flange



过滤器  
Filter



气动三联件  
Pneumatic FRL



阀门  
Valve



快速接头  
Quick coupling



转换接头  
Adapter



## 周边产品

### 气动粉体泵

Powder diaphragm pump



### 智能灌装设备

Intelligent filling equipment



### 可憋压电动泵

Electric Diaphragm Pump with Pressure Relief Controller



### 气动喷涂泵

Spray pump



## 泵系统图

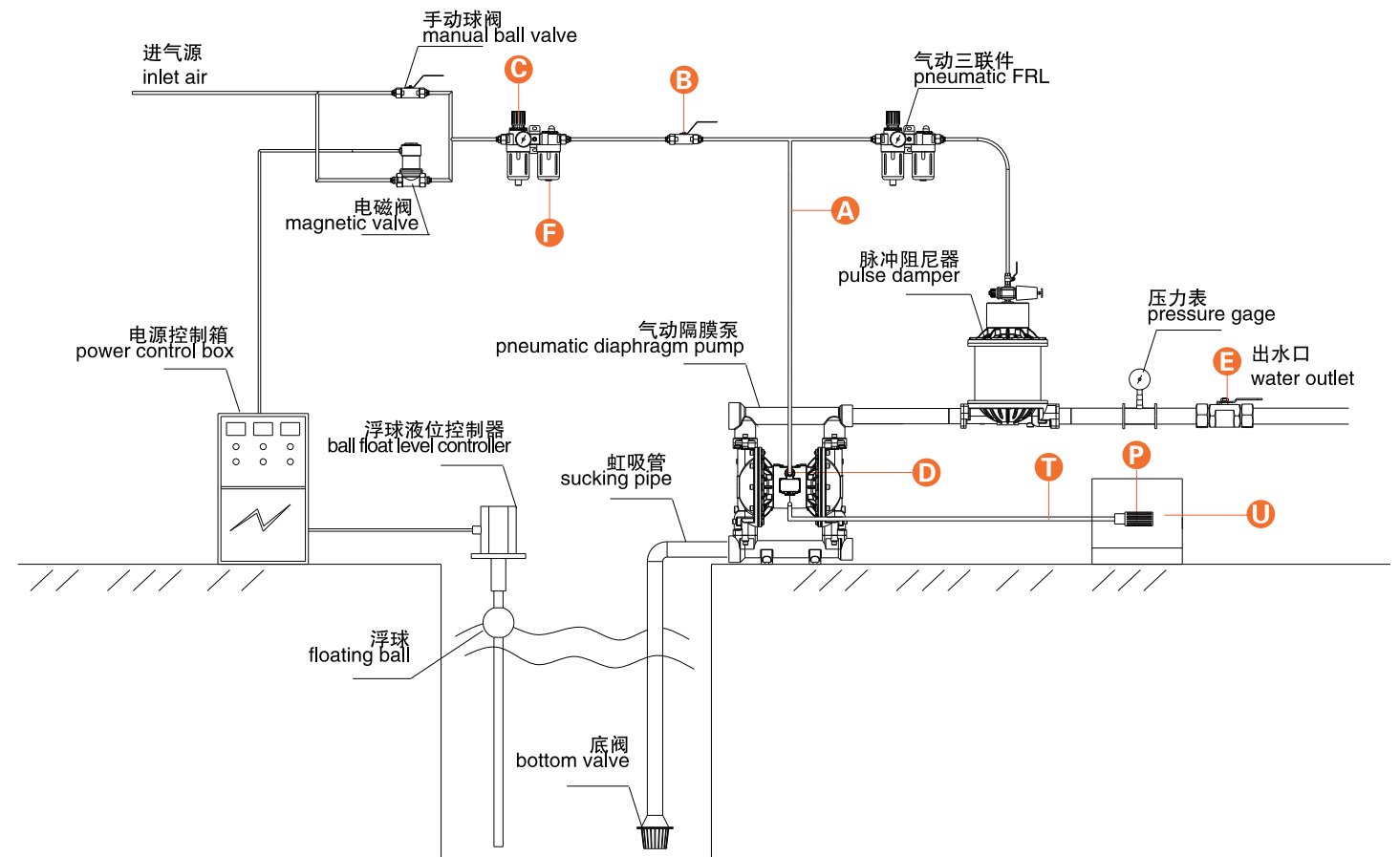

A 供气管线 Gas Pipeline

B 铜球阀 Cuprum Ball Valve

C 空气调压器 Air Pressure Regulator

D 进气管快速接头 Intake Pipe Quick Connection

E 漏式铜球阀 Leak Type Cuprum Ball Valve

F 气动三联件 Pneumatic FRL

P 消声器 Muffler

T 排气管 Exhaust Pipe

U 排气用的容器 Container For Exhaust

# 过流部件抗腐蚀性参数表

## Anti-Corrosion Parameter List of Wetted Parts

腐蚀性流体 Corrosive fluid	液体浓度 (%) Liquid concentration																			
	5	10	15	20	25	30	35	40	45	50	55	60	65	70	75	80	85	90	95	100
醋酸 (常温) Acetic Acid(Ambient)																				
醋酸 (热的) Acetic Acid ( Hot)																				
醋酸 (沸腾的) Acetic Acid(Boiling)																				
铬酸 Chromic Acids(Conc)																				
硝酸 Nitric Acid																				
磷酸 (常温的) Phosphoric Acid(Ambient)																				
磷酸 (热的) Phosphoric Acid(Hot)																				
磷酸 (沸腾的) Phosphoric Acid(Boiling)																				
氢氧化钾 (<60° C) Potassium Hydroxide(<140° F)																				
氢氧化钾 (<85° C) Potassium Hydroxide(<185° F)																				
氯化钠 Sodium Hypochloride																				
氢氧化镁 Magnesium Hydroxide																				
氢氧化钠 Sodium Hydroxide																				
盐酸 Hydrochloric Acid																				
盐酸 (沸腾的) Hydrochloric Acid(Boiling)																				
氢氟酸 (常温的) Hydrofluoric Acid(Ambient)																				
氢氟酸 (沸腾的) Hydrofluoric Acid(Boiling)																				
氢氟酸 Hydrofluoric Acid(Conc)																				
硫酸 (<51.6℃) Sulfuric Acid(<125° F)																				
硫酸 (51.6℃ ~ 79.5℃) Sulfuric Acid(125 ~ 175° F)																				
硫酸 (沸腾的) Sulfuric Acid(Biling)																				

PP 聚丙烯  
 SST 不锈钢  
 PTFE 四氟  
 Without standard 暂无数据

# 过流部件抗腐蚀性参数表

## Anti-Corrosion Parameter List of Wetted Parts

腐蚀性液体	铝合金	不锈钢	聚丙烯	丁腈橡胶	三元乙丙橡胶	氟橡胶	聚四氟乙烯	聚酯
沥青	●	●	●				●	
基液	●	●	●			●	●	
乙炔	●	●	●	●				●
亚麻仁油	●	●	●		●		●	
乙醇	●	●	●	●		●	●	
甲醇	●	●	●	●		●	●	
氨液	●	●	●		●		●	
亚硫酸溶液	●	●	●			●	●	
威士忌酒	●	●	●		●		●	
乙醚	●	●	●			●	●	
乙醇胺	●	●	●			●	●	
乙二醇	●	●	●	●			●	
液化石油气	●	●	●		●		●	
氯化铵	●	●	●				●	
氯化钾 (干)	●	●	●	●			●	
氯化氢气体 (干)	●	●	●			●	●	
氯化铜 (干)	●	●	●	●			●	
氯化钠	●	●	●	●			●	
氯化钡	●	●	●	●			●	
氯化钙	●	●	●	●			●	
氯化镁	●	●	●	●			●	
二氯甲烷	●	●	●	●			●	
氯气	●	●	●	●			●	
氯 (干)	●	●	●	●			●	
手烧	●	●	●			●	●	
油酸	●	●	●			●	●	
汽油 (精制)	●	●	●			●	●	
汽油 (粗制)	●	●	●			●	●	
过氧化钠	●	●	●			●	●	
果汁	●	●	●			●	●	
过硼酸钠	●	●	●			●	●	
二甲苯/混合二甲苯	●	●	●			●	●	
蚁酸	●	●	●			●	●	
挥发油/桐油	●	●	●			●	●	
柠檬酸	●	●	●			●	●	
脂	●	●	●	●		●	●	
焦油	●	●	●	●		●	●	
乙二醇	●	●	●	●		●	●	
杂醇油	●	●	●			●	●	
甲苯基酸	●	●	●			●	●	
三氯甲烷 (干)	●	●	●			●	●	
硅酸钠	●	●	●			●	●	
玉米油	●	●	●			●	●	
醋酸	●	●	●			●	●	
醋酸异丙酯	●	●	●			●	●	
乙酸异丁酯	●	●	●			●	●	
醋酸乙酯	●	●	●			●	●	
醋酸钙	●	●	●			●	●	
醋酸丁酯	●	●	●			●	●	
甘蔗砂糖液	●	●	●			●	●	
甜菜	●	●	●			●	●	
氯	●	●	●			●	●	
氯化钾	●	●	●	●		●	●	
氯化钠 (稀)	●	●	●	●		●	●	
环乙烷	●	●	●			●	●	
草酸	●	●	●			●	●	
硅油	●	●	●			●	●	
喷气发动机燃料	●	●	●			●	●	
脂肪酸	●	●	●			●	●	
油石酸	●	●	●			●	●	
硝酸	●	●	●			●	●	
硝酸铝	●	●	●	●		●	●	
硝酸铵	●	●	●	●		●	●	
硝酸铋	●	●	●	●		●	●	
硝酸钙	●	●	●	●		●	●	
硝酸铁	●	●	●	●		●	●	
硝酸钾	●	●	●	●		●	●	
硝酸镁	●	●	●	●		●	●	
熟石灰	●	●	●	●		●	●	
植物油	●	●	●	●		●	●	
亚硝酸钙	●	●	●	●		●	●	
明胶	●	●	●	●		●	●	
碳酸氢钠	●	●	●	●		●	●	
硬脂酸	●	●	●	●		●	●	
硬脂酸丁酯	●	●	●	●		●	●	
汞	●	●	●	●		●	●	
氢氧化铵	●	●	●	●		●	●	

腐蚀性液体	铝合金	不锈钢	聚丙烯	丁腈橡胶	三元乙丙橡胶	氟橡胶	聚四氟乙烯	聚酯
氢氧化镁	●	●	●			●	●	
氢	●	●	●			●	●	
明胶	●	●	●	●		●	●	
碳酸 (苯酚)	●	●	●			●	●	
石油 原油	●	●	●			●	●	
氯酸	●	●	●			●	●	
石灰硫酸	●	●	●			●	●	
肥皂水	●	●	●			●	●	
洗涤剂 (合成)	●	●	●	●		●	●	●
苏打粉	●	●	●	●		●	●	●
豆油	●	●	●			●	●	
碳酸	●	●	●	●		●	●	
碳酸钠	●	●	●	●		●	●	
碳酸镁	●	●	●	●		●	●	
糠酸 (稀)	●	●	●	●		●	●	
硫代硫酸钠	●	●	●	●		●	●	●
柴油	●	●	●	●		●	●	
四氯乙烯	●	●	●	●		●	●	
天然气	●	●	●	●		●	●	
三氯乙烯	●	●	●	●		●	●	
甲苯	●	●	●	●		●	●	
煤油	●	●	●	●		●	●	
粗制汽油	●	●	●	●		●	●	●
苯	●	●	●	●		●	●	●
环烷酸	●	●	●	●		●	●	●
(动物) 胶	●	●	●	●		●	●	●
甲酸硝石	●	●	●	●		●	●	●
氯化乙烷 (干)	●	●	●	●		●	●	●
二硫化碳	●	●	●	●		●	●	
乳酸	●	●	●	●		●	●	
尿素	●	●	●	●		●	●	
石蜡	●	●	●	●		●	●	
棕榈酸	●	●	●	●		●	●	
白液 (造纸厂)	●	●	●	●		●	●	
蓖麻油	●	●	●	●		●	●	
苦味酸	●	●	●	●		●	●	
啤酒	●	●	●	●		●	●	
氟利昂	●	●	●	●		●	●	
丙烷	●	●	●	●		●	●	
丙二醇	●	●	●	●		●	●	
丁烷	●	●	●	●		●	●	
丁醇	●	●	●	●		●	●	
丁二烯	●	●	●	●		●	●	●
葡萄糖	●	●	●	●		●	●	
氯化铝 (干)	●	●	●	●		●	●	
乙烷	●	●	●	●		●	●	
苯	●	●	●	●		●	●	
挥发油	●	●	●	●		●	●	●
福尔马林	●	●	●	●		●	●	
甲酸	●	●	●	●		●	●	
硝酸	●	●	●	●		●	●	
硝酸钠	●	●	●	●		●	●	
牛乳	●	●	●	●		●	●	
明胶	●	●	●	●		●	●	
无水氨	●	●	●	●		●	●	
醋酸酐	●	●	●	●		●	●	
苯酚	●	●	●	●		●	●	
甲醇	●	●	●	●		●	●	
甲烷	●	●	●	●		●	●	
甲苯	●	●	●	●		●	●	●
椰子油	●	●	●	●		●	●	
猪油	●	●	●	●		●	●	
油漆	●	●	●	●		●	●	●
亚麻酸	●	●	●	●		●	●	
磷酸铵	●	●	●	●		●	●	
磷酸钠	●	●	●	●		●	●	
氯化钠	●	●	●	●		●	●	
氯化钡	●	●	●	●		●	●	
氯化铝	●	●	●	●		●	●	●
硫酸铵	●	●	●	●		●	●	
硫酸钾	●	●	●	●		●	●	
硫酸钠	●	●	●	●		●	●	
硫酸镁	●	●	●	●		●	●	
硫酸铋	●	●	●	●		●	●	●
硫酸亚铁	●	●	●	●		●	●	
松香	●	●	●	●		●	●	
葡萄酒	●	●	●	●		●	●	
清漆	●	●	●	●		●	●	
氢氧化钙	●	●	●	●		●	●	
氢氧化钠	●	●	●	●		●	●	

表中●表示适用  
具体选型请咨询业务部门