

05

GDC
船用泵



GDC-40 不锈钢304



性能曲线图

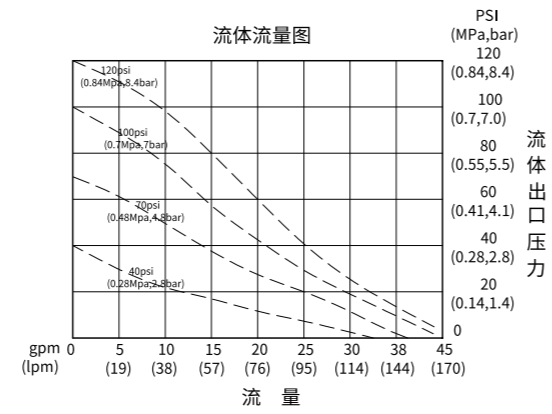

规格参数

最大流量 Max. Flow	150 L/min
最大排出压力 Max. discharge pressure	0.7 Mpa
真空度 Vacuum degree	0.05 Mpa

最大空气消耗量 Max. air consumption	90 m ³ /h
吸程 Suction lift	5 m
最大允许颗粒直径 Max. Passing particle diameter	3.2 mm

安装尺寸图

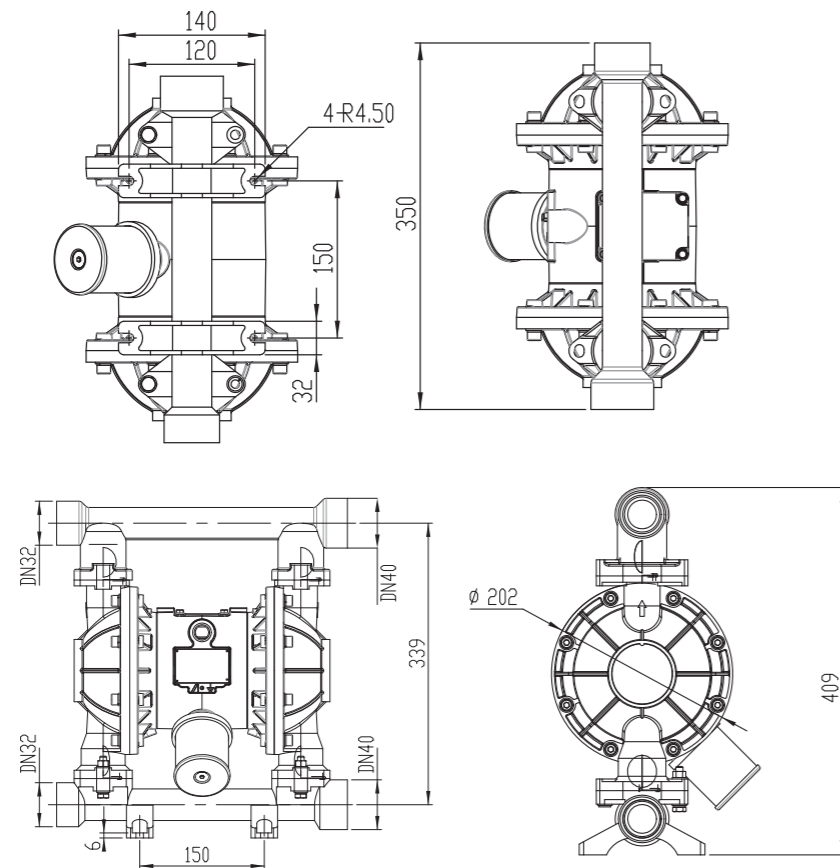

GDC-50 不锈钢304



性能曲线图

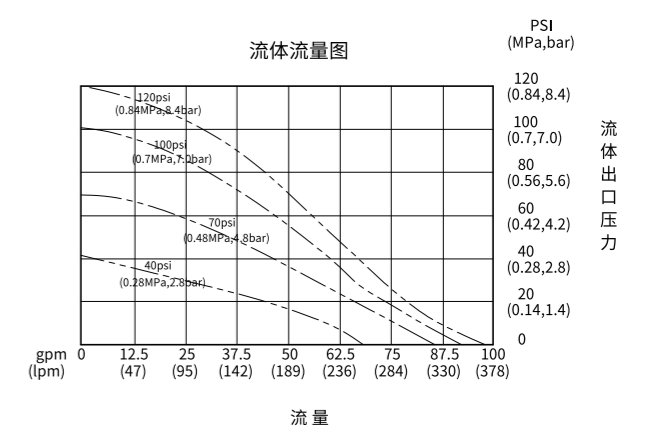

规格参数

最大流量 Max. Flow	250 L/min
最大排出压力 Max. discharge pressure	0.7 Mpa
真空度 Vacuum degree	0.05 Mpa

最大空气消耗量 Max. air consumption	180 m ³ /h
吸程 Suction lift	5 m
最大允许颗粒直径 Max. Passing particle diameter	5.48 mm

安装尺寸图

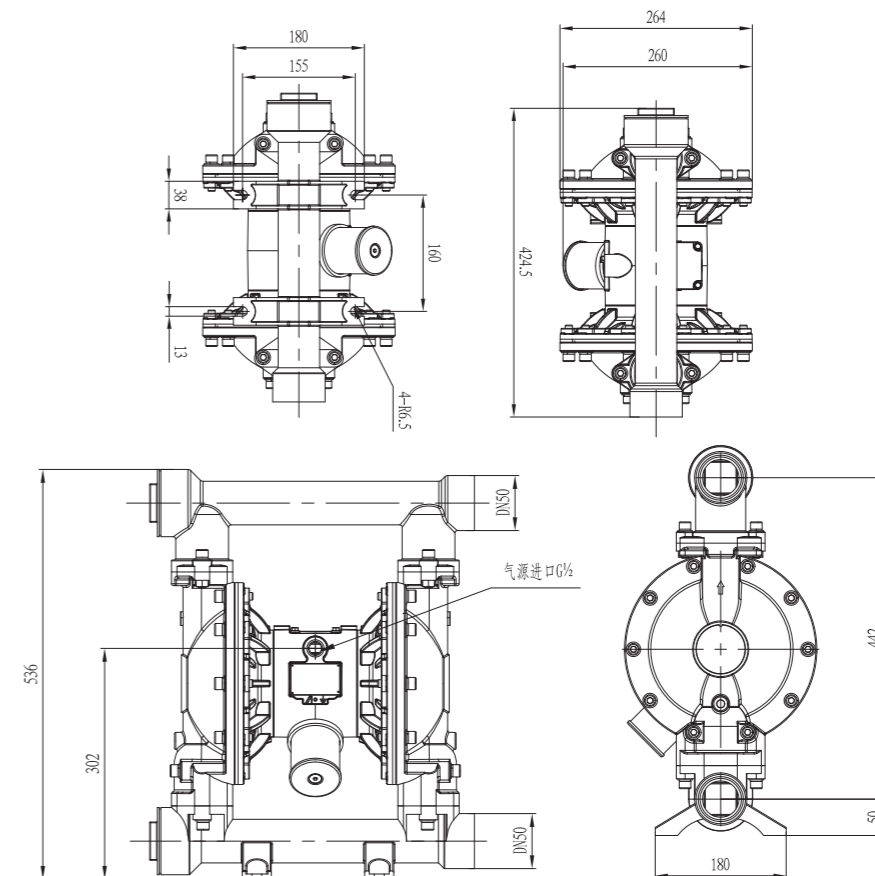

GDC-80 不锈钢304



性能曲线图

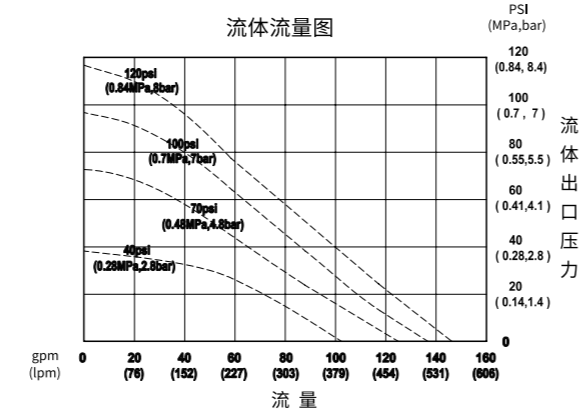

规格参数

最大流量 Max. Flow	450 L/min
最大排出压力 Max. discharge pressure	0.7 Mpa
真空度 Vacuum degree	0.05 Mpa

最大空气消耗量 Max. air consumption	252 m ³ /h
吸程 Suction lift	5 m
最大允许颗粒直径 Max. Passing particle diameter	6.3 mm

安装尺寸图

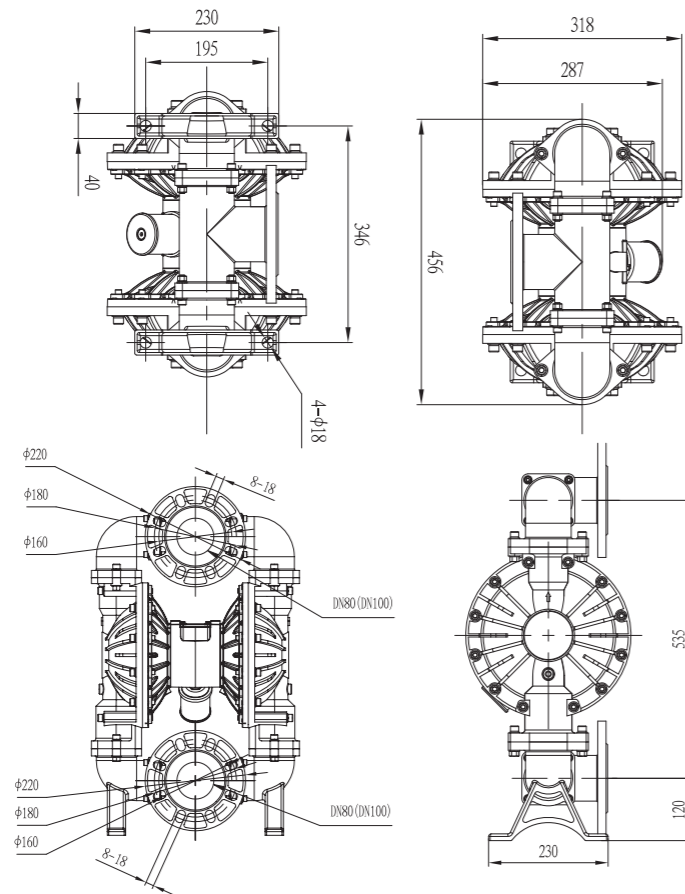

GDC-125 不锈钢304



性能曲线图

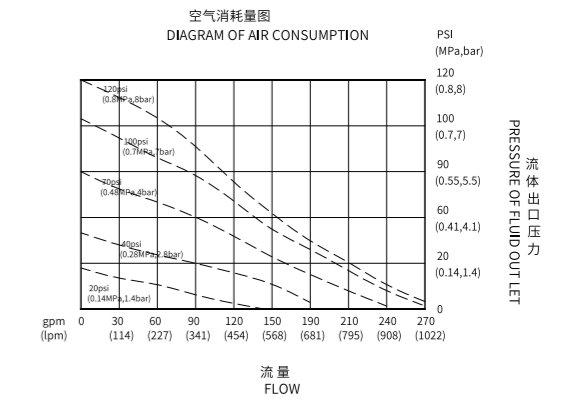

规格参数

最大流量 Max. Flow	800 L/min
最大排出压力 Max. discharge pressure	0.7 Mpa
真空度 Vacuum degree	0.05 Mpa

最大空气消耗量 Max. air consumption	468 m ³ /h
吸程 Suction lift	5 m
最大允许颗粒直径 Max. Passing particle diameter	9.4 mm

安装尺寸图

